

**MULTIPLE CHOICE.** Choose the one alternative that best completes the statement or answers the question.

Match the quadratic function to the correct graph.

1)  $y = (x + 6)^2$

A)

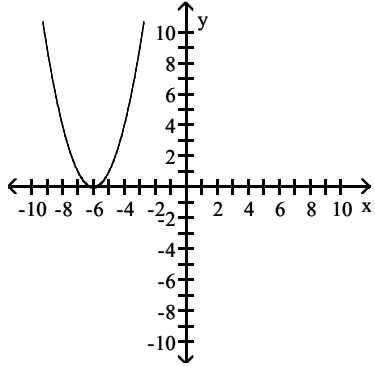

B)

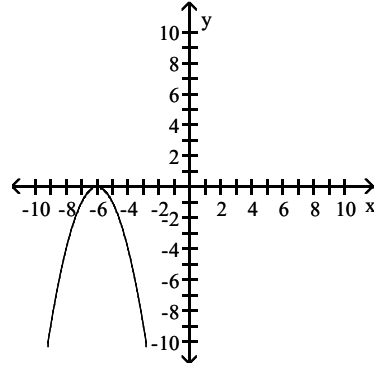

C)

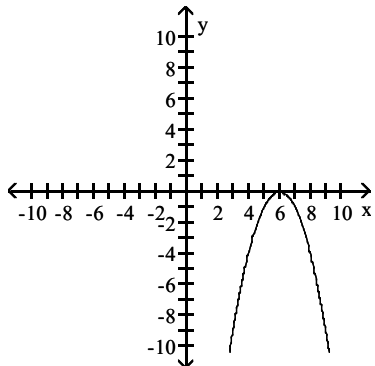

D)

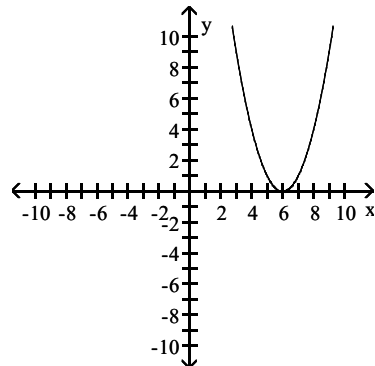

Answer: A

2)  $y = -(x + 5)^2 + 4$

A)

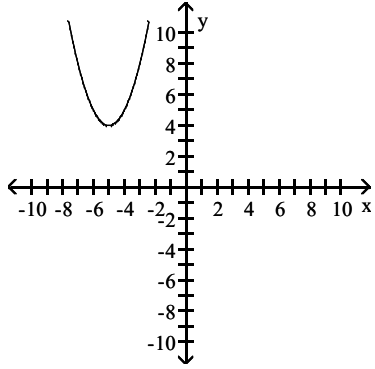

B)

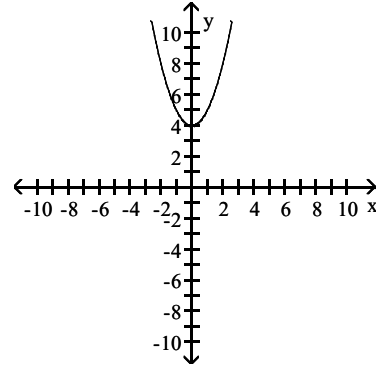

C)

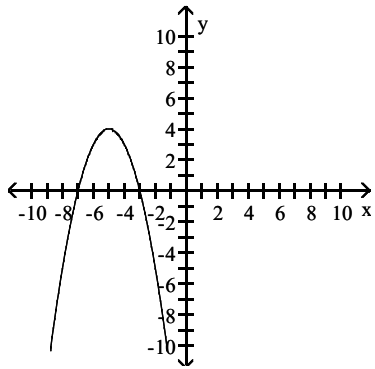

D)

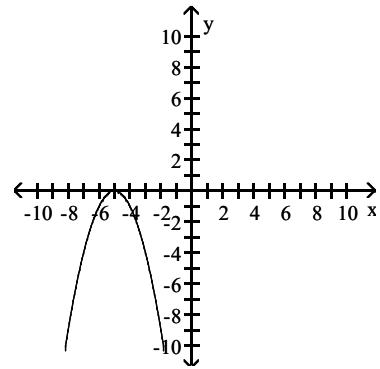

Answer: C

3)  $y = 2(x + 3)^2 - 3$

A)

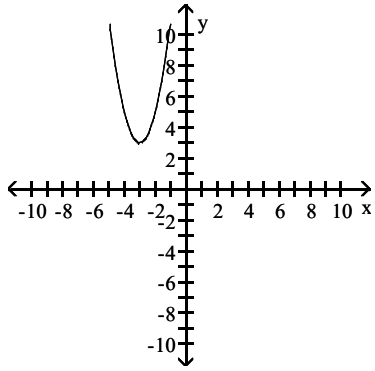

B)

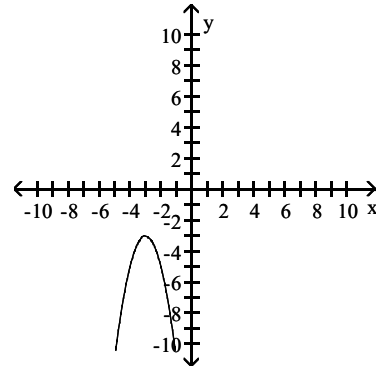

C)

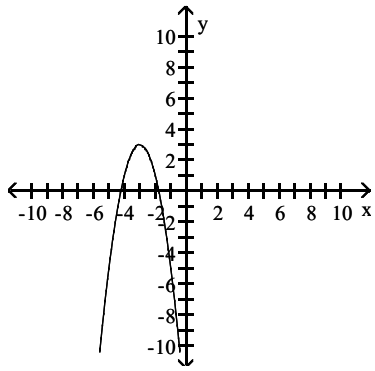

D)

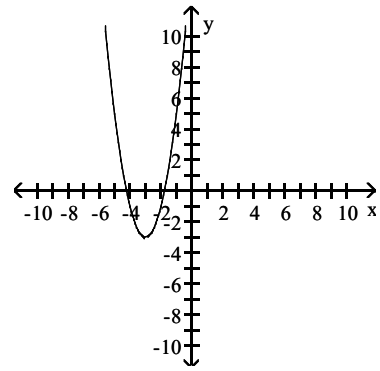

Answer: D

4)  $y = x^2 - 7$

A)

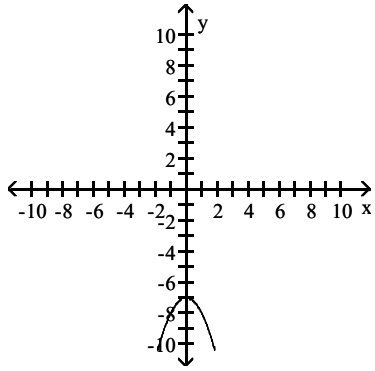

B)

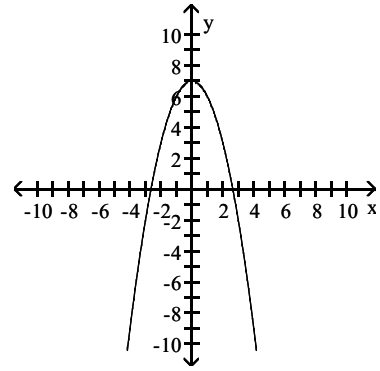

C)

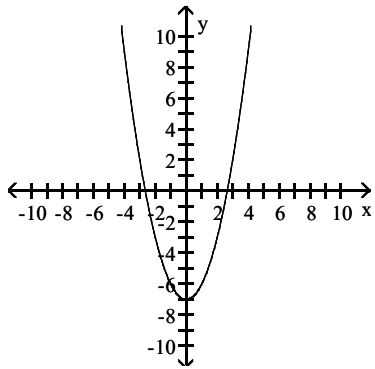

D)

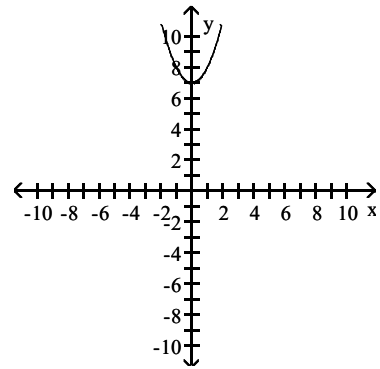

Answer: C

$$5) y = \frac{1}{3}(x - 5)^2 + 4$$

A)

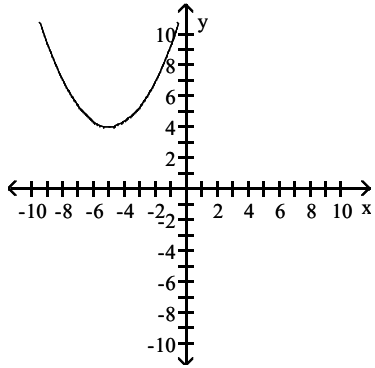

B)

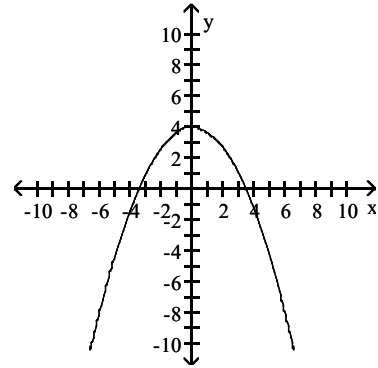

C)

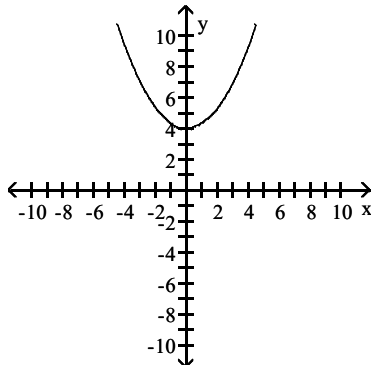

D)

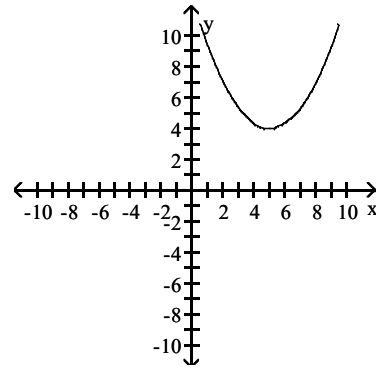

Answer: D

$$6) y = -\frac{1}{3}(x+5)^2 - 3$$

A)

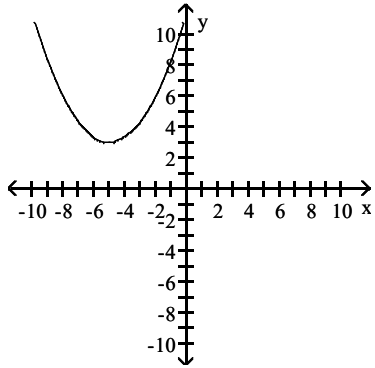

C)

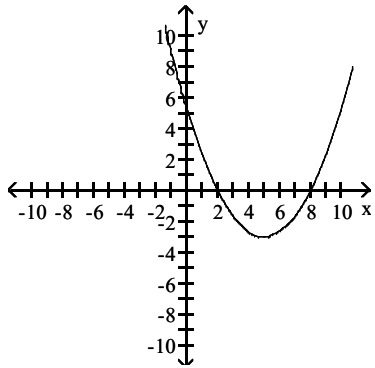

B)

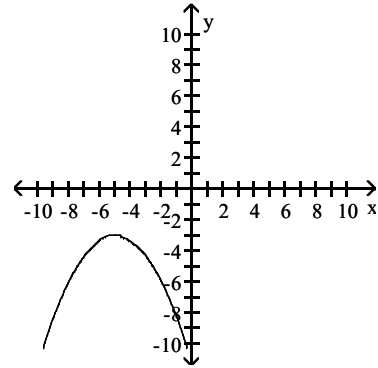

D)

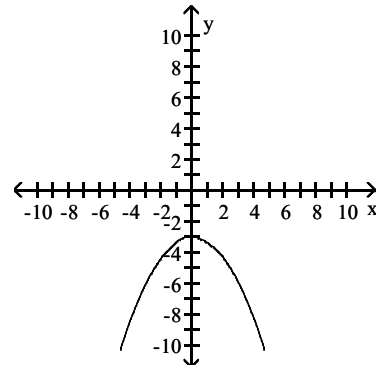

Answer: B

7)  $y = (x - 1)^2$

A)

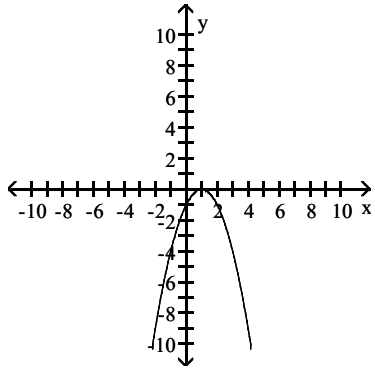

B)

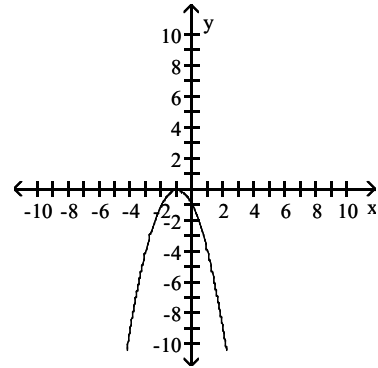

C)

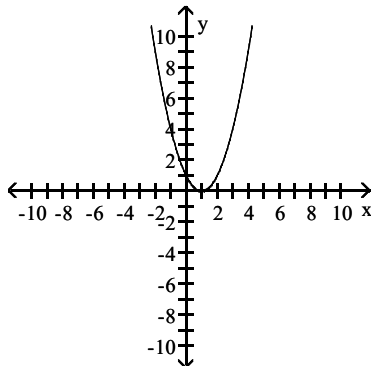

D)

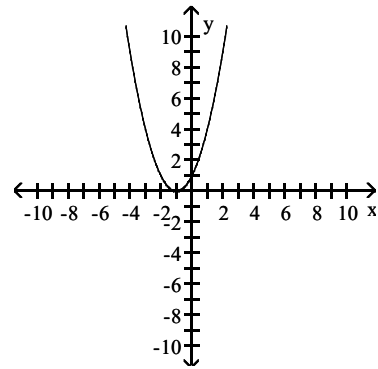

Answer: C

8)  $y = -(x + 6)^2 + 5$

A)

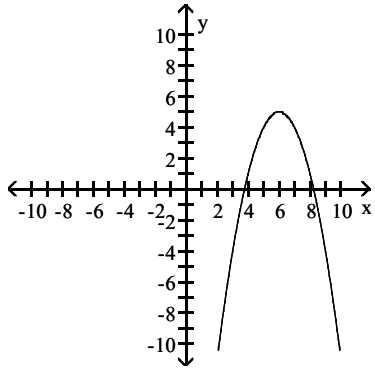

B)

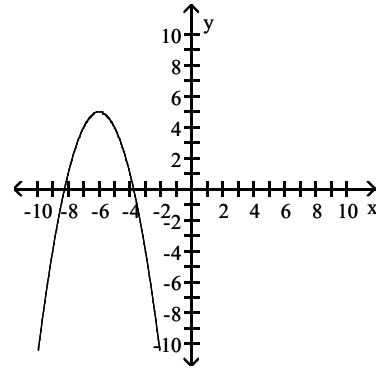

C)

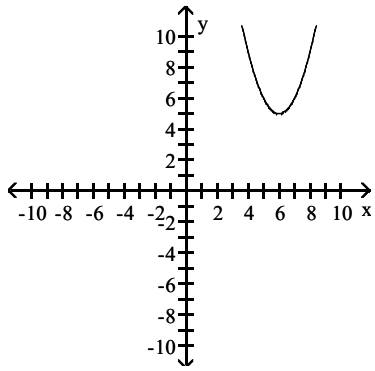

D)

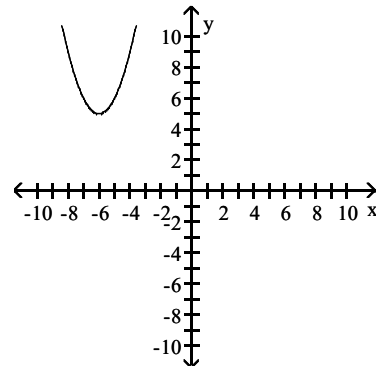

Answer: B



9)  $y = 2(x - 4)^2 - 3$

A)

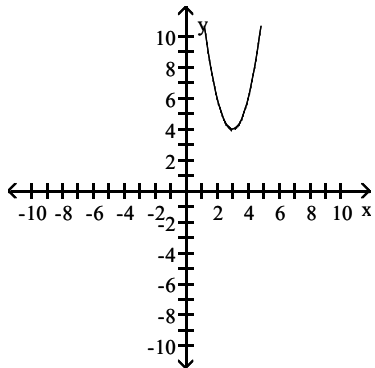

B)

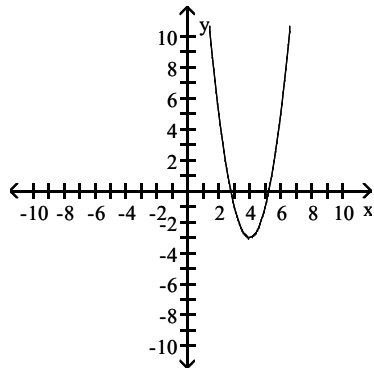

C)

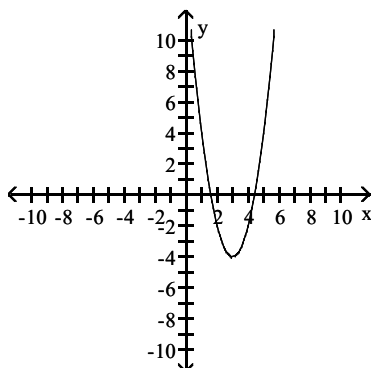

D)

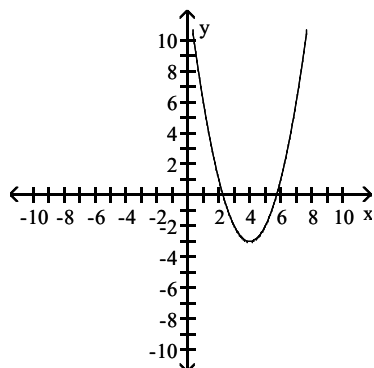

Answer: B

Find the quadratic function  $y = f(x)$  that has the given vertex and whose graph passes through the given point.

10) (4, 96)

A)  $y = 4x^2$

B)  $y = 6x^2$

C)  $y = \frac{1}{6}x^2$

D)  $y = -6x^2$

Answer: B

11) (-4, -96)

A)  $y = -6x^2$

B)  $y = -\frac{1}{6}x^2$

C)  $y = -4x^2$

D)  $y = 6x^2$

Answer: A

12) (3, 3)

A)  $y = -\frac{1}{3}x^2$

B)  $y = -3x^2$

C)  $y = \frac{1}{3}x^2$

D)  $y = 3x^2$

Answer: C

13) vertex: (4, 1) passing through: (3, 2)

A)  $y = x^2 - 4x + 1$

B)  $y = -x^2 - 8x + 1$

C)  $y = x^2 - 8x + 17$

D)  $y = 3x^2 - 8x + 17$

Answer: C

14) vertex: (-2, -2) passing through: (-4, 2)

A)  $y = x^2 + 2x + 2$

B)  $y = -4x^2 - 4x - 2$

C)  $y = -x^2 + 4x + 2$

D)  $y = x^2 + 4x + 2$

Answer: D

15) vertex:  $(-1, -4)$  passing through:  $(-3, -8)$

A)  $y = -3x^2 + 2x + 5$

B)  $y = -x^2 + 1x - 4$

C)  $y = x^2 + 2x - 4$

D)  $y = -x^2 - 2x - 5$

Answer: D

16) vertex  $(8, 6)$ ; passing through  $(4, 7)$

A)  $y = \frac{1}{16}(x + 8)^2 - 6$

B)  $y = (x - 8)^2 + 6$

C)  $y = \frac{1}{16}(x + 8)^2 + 6$

D)  $y = \frac{1}{16}(x - 8)^2 + 6$

Answer: D

17) vertex  $(0, 8)$ ; passing through  $(-2, 0)$

A)  $y = 8x^2 + 8$

B)  $y = -2x^2 - 8$

C)  $y = -2x^2 + 8$

D)  $y = x^2 + 8$

Answer: C

18) vertex  $(-5, 0)$ ; passing through  $(-6, -5)$

A)  $y = (x - 5)^2$

B)  $y = (x + 5)^2$

C)  $y = -5(x - 5)^2$

D)  $y = -5(x + 5)^2$

Answer: D

19) vertex  $(-4, -7)$ ; passing through  $(5, -1)$

A)  $y = 6(x - 4)^2 - 7$

B)  $y = \frac{2}{27}(x + 4)^2 + 7$

C)  $y = \frac{8}{81}(x - 4)^2 + 7$

D)  $y = \frac{2}{27}(x + 4)^2 - 7$

Answer: D

20) vertex  $\left(\frac{4}{3}, \frac{4}{3}\right)$ ; passing through  $\left(-\frac{4}{15}, \frac{2}{15}\right)$

A)  $y = -\frac{15}{32}\left(x - \frac{4}{3}\right)^2 - \frac{4}{3}$

B)  $y = -\frac{15}{32}\left(x - \frac{4}{3}\right)^2 + \frac{4}{3}$

C)  $y = \frac{15}{32}\left(x - \frac{4}{3}\right)^2 - \frac{4}{3}$

D)  $y = \frac{15}{32}\left(x + \frac{4}{3}\right)^2 + \frac{4}{3}$

Answer: B

21) vertex  $\left(\frac{4}{3}, -\frac{8}{9}\right)$ ; passing through  $\left(\frac{11}{9}, -1\right)$

A)  $y = -9(x + a)^2 - \frac{8}{9}$

B)  $y = -9(x - a)^2 - \frac{8}{9}$

C)  $y = -9(x - a)^2 + \frac{8}{9}$

D)  $y = -9(x + a)^2 + \frac{8}{9}$

Answer: B

The graph of a quadratic function is given. Find the standard form of the function

22)

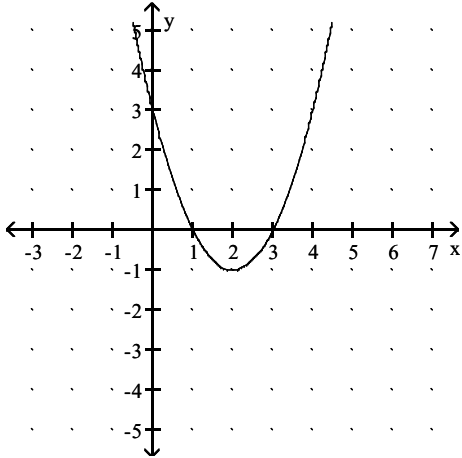

A)  $f(x) = (x + 2)^2 - 1$

B)  $f(x) = -(x - 2)^2 - 1$

C)  $f(x) = (x - 2)^2 + 1$

D)  $f(x) = (x - 2)^2 - 1$

Answer: D

23)

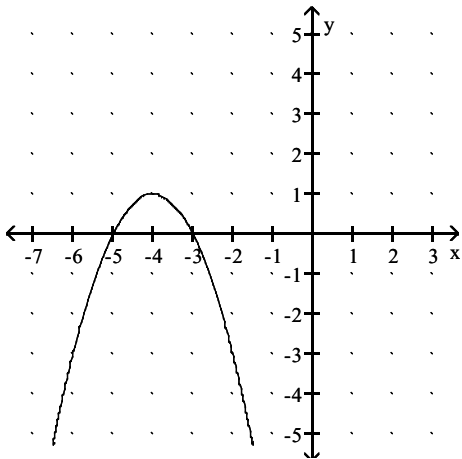

A)  $f(x) = -(x + 4)^2 - 1$

B)  $f(x) = (x + 4)^2 + 1$

C)  $f(x) = -(x + 4)^2 + 1$

D)  $f(x) = -(x - 4)^2 + 1$

Answer: C

24)

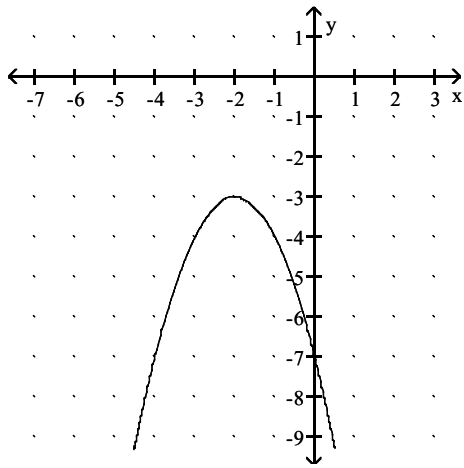

A)  $f(x) = -(x + 2)^2 + 3$

B)  $f(x) = -(x + 2)^2 - 3$

C)  $f(x) = -(x - 2)^2 - 3$

D)  $f(x) = (x + 2)^2 - 3$

Answer: B

25)

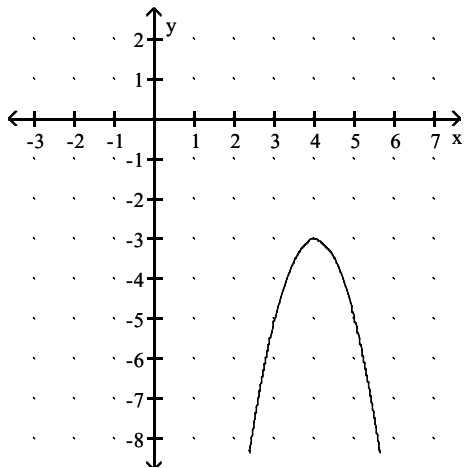

A)  $f(x) = -\frac{1}{2}(x + 4)^2 - 3$

B)  $f(x) = -(x - 4)^2 - 3$

C)  $f(x) = -2(x - 4)^2 - 3$

D)  $f(x) = -\frac{1}{2}(x - 4)^2 - 3$

Answer: C

26)

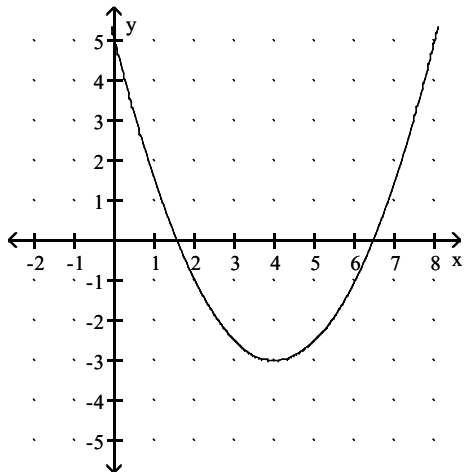

A)  $f(x) = \frac{1}{2}(x - 4)^2 - 3$

B)  $f(x) = \frac{1}{2}(x + 4)^2 - 3$

C)  $f(x) = 2(x - 4)^2 - 3$

D)  $f(x) = (x - 4)^2 - 3$

Answer: A

Graph the function by starting with the graph of  $y = x^2$  and using transformations.

27)  $f(x) = (x - 1)^2$

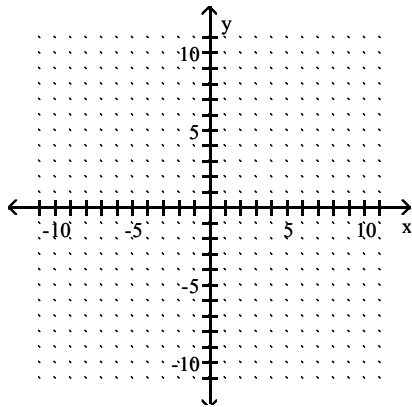

A)

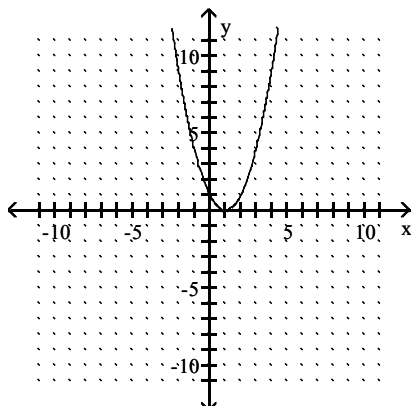

B)

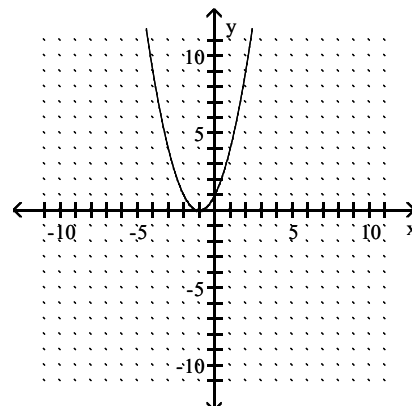

C)

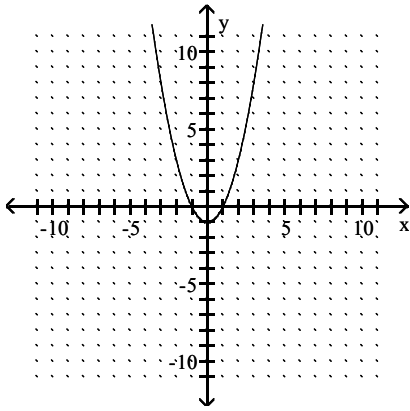

D)

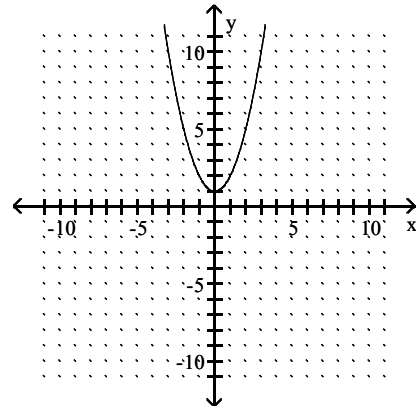

Answer: A

28)  $f(x) = 4(x - 1)^2 - 4$

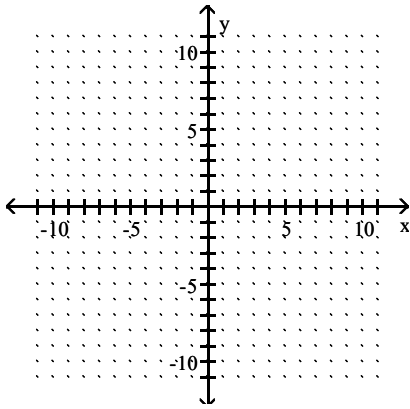

A)

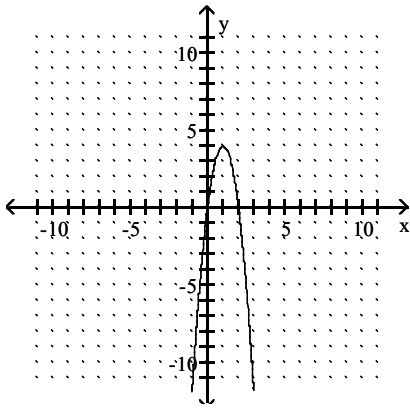

B)

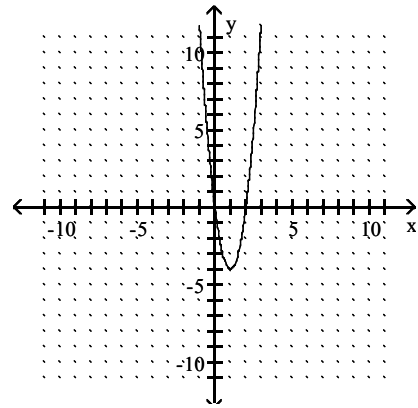

C)

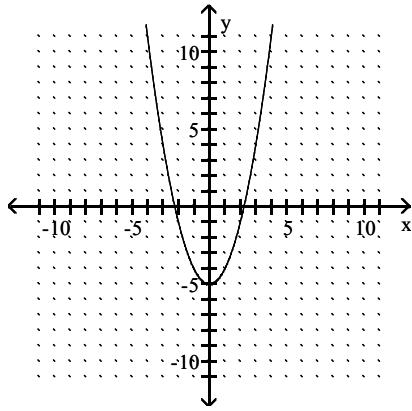

D)

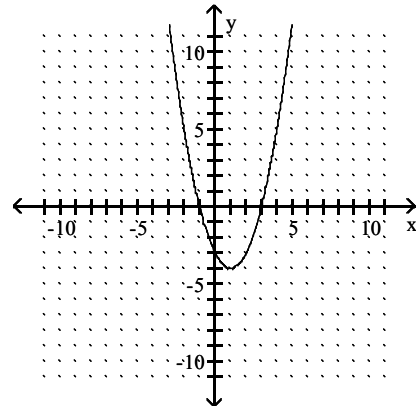

Answer: B

29)  $f(x) = -5(x + 2)^2 + 1$

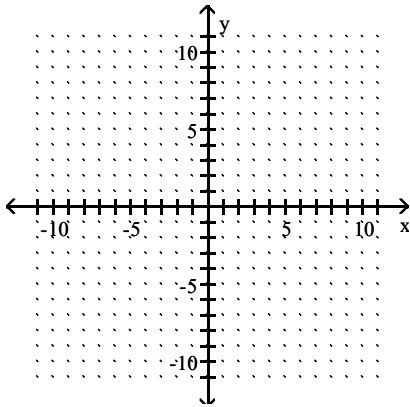

A)

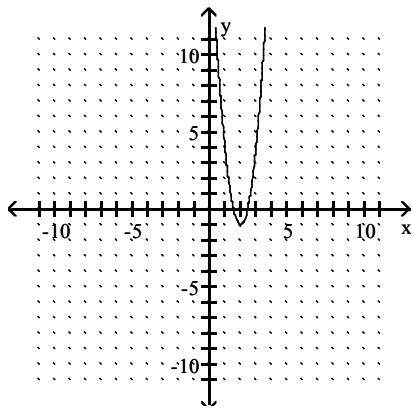

B)

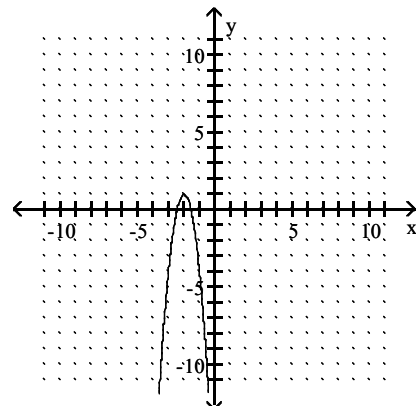

C)

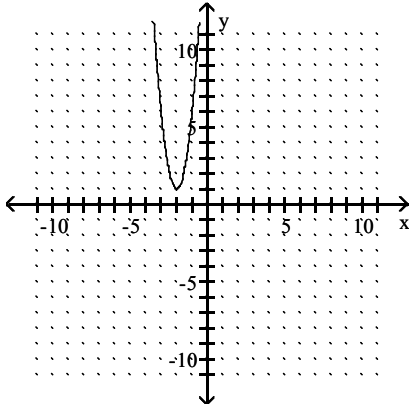

D)

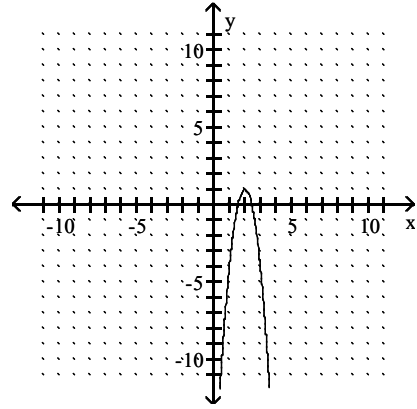

Answer: B

30)  $f(x) = (x - 3)^2 - 4$

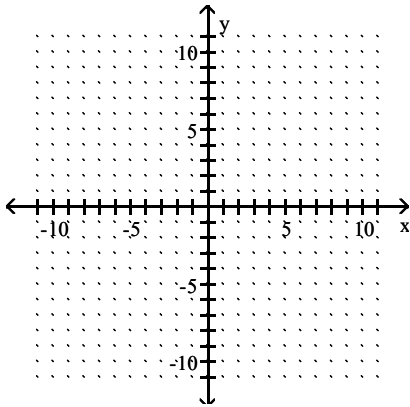

A)

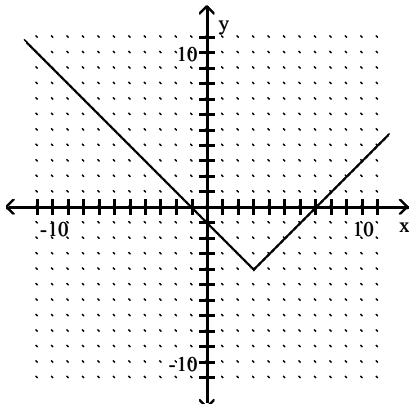

B)

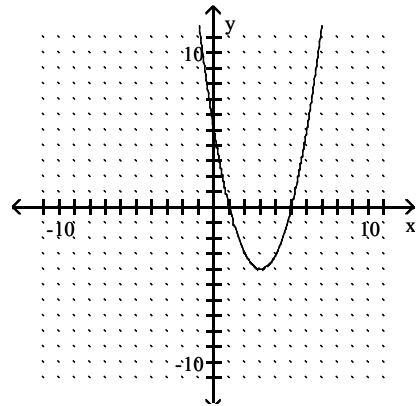



C)

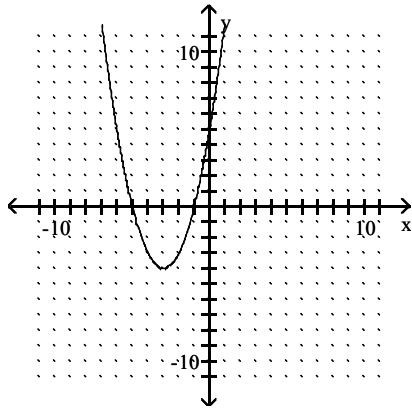

Answer: B

D)

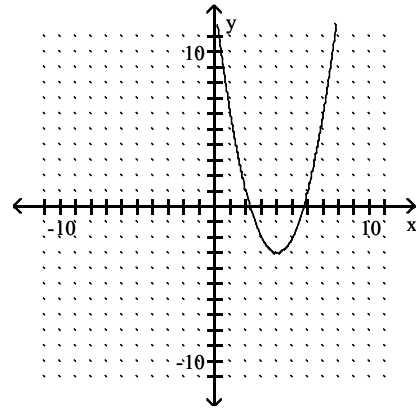

Write the quadratic function in the standard form  $y = a(x - h)^2 + k$ .

31)  $y = x^2 - 18x$

A)  $y = (x - 18)^2 - 324$

B)  $y = (x - 9)^2 - 81$

C)  $y = (x + 9)^2 - 9$

D)  $y = (x + 18)^2 - 18$

Answer: B

32)  $y = x^2 + 6x - 1$

A)  $y = (x - 3)^2 - 10$

B)  $y = (x - 3)^2 + 10$

C)  $y = (x + 3)^2 - 10$

D)  $y = (x + 3)^2 + 10$

Answer: C

33)  $y = -2x^2 - 16x - 27$

A)  $y = -2(x - 4)^2 + 5$

B)  $y = -2(x + 4)^2 + 5$

C)  $y = (x + 4)^2 + 5$

D)  $y = 2(x + 4)^2 + 5$

Answer: B

Graph the given function. Identify the vertex and the intercepts.

34)  $y = x^2 + 2x - 8$

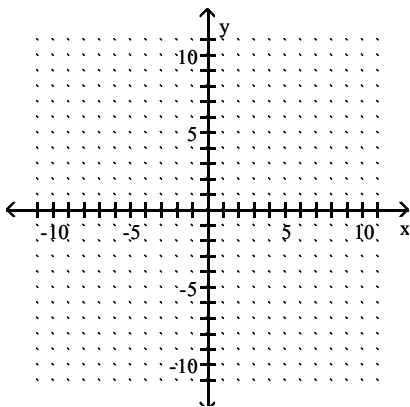

- A) Vertex:  $(1, -9)$   
 x-intercepts:  $-2$  and  $4$   
 y-intercept:  $-8$

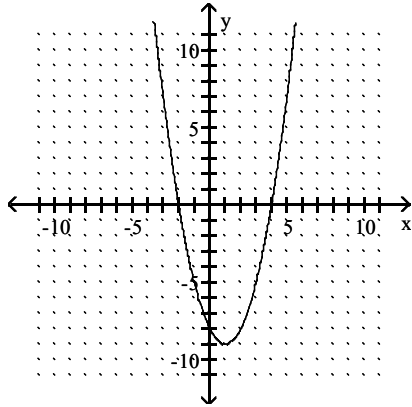

- B) Vertex:  $(1, -9)$   
 x-intercepts:  $-2$  and  $4$   
 y-intercept:  $8$

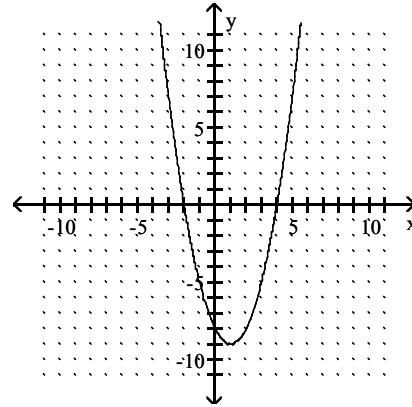

- C) Vertex:  $(-1, -9)$   
 x-intercepts:  $-4$  and  $2$   
 y-intercept:  $-8$

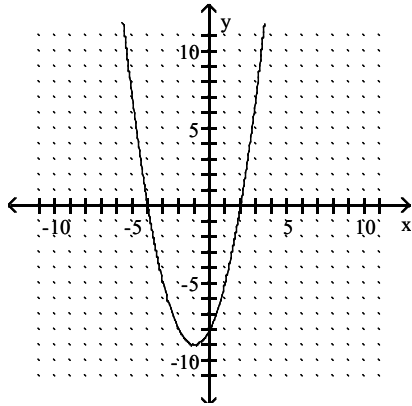

- D) Vertex:  $(-1, -9)$   
 x-intercepts:  $4$  and  $2$   
 y-intercept:  $-8$

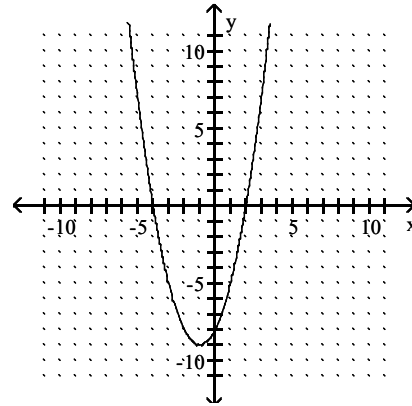

Answer: C

35)  $y = 8 - x^2 + 2x$

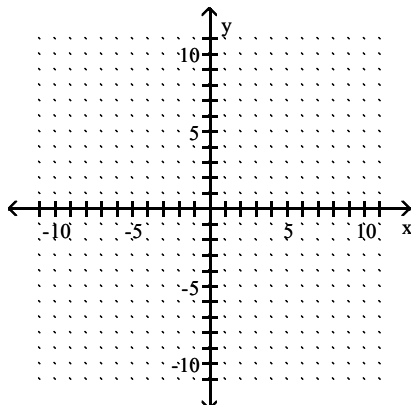

- A) Vertex:  $(-1, 9)$   
 x-intercepts:  $-4$  and  $2$   
 y-intercept:  $8$

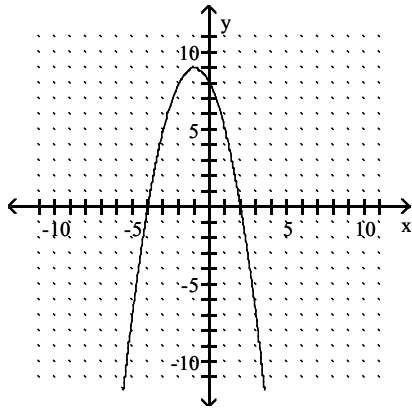

- B) Vertex:  $(1, -9)$   
 x-intercepts:  $-2$  and  $4$   
 y-intercept:  $-8$

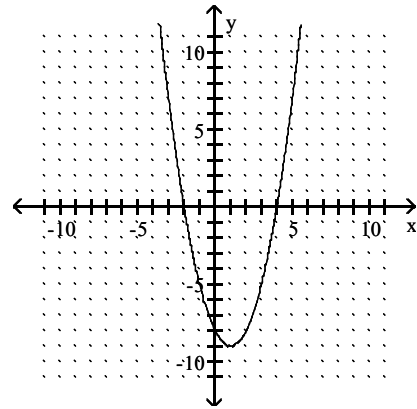

- C) Vertex:  $(1, 9)$   
 x-intercepts:  $-4$  and  $2$   
 y-intercept:  $8$

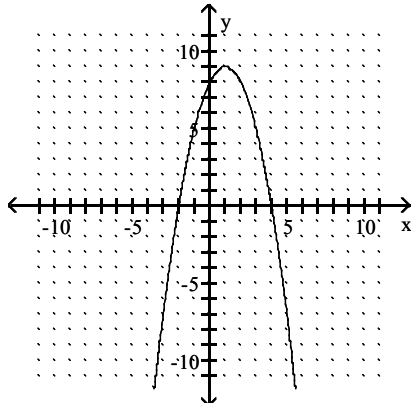

- D) Vertex:  $(1, 9)$   
 x-intercepts:  $-2$  and  $4$   
 y-intercept:  $8$

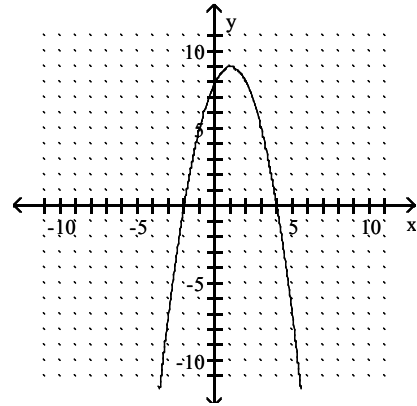

Answer: D

36)  $y = x^2 + 5x + 6$

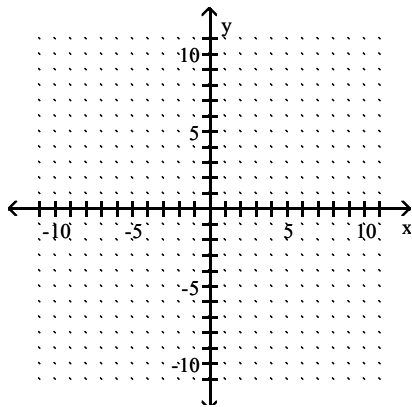

A) Vertex:  $\left(\frac{5}{2}, -\frac{1}{4}\right)$

x-intercepts: -3 and -2

y-intercept: 6

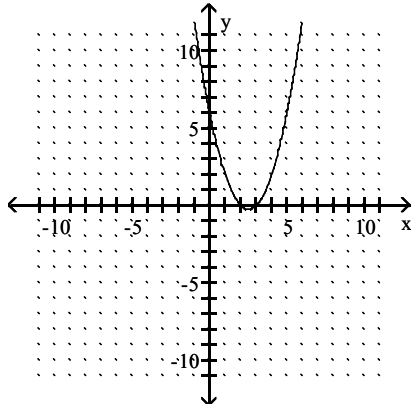

B) Vertex:  $\left(\frac{5}{2}, -\frac{1}{4}\right)$

x-intercepts: 3 and 2

y-intercept: 6

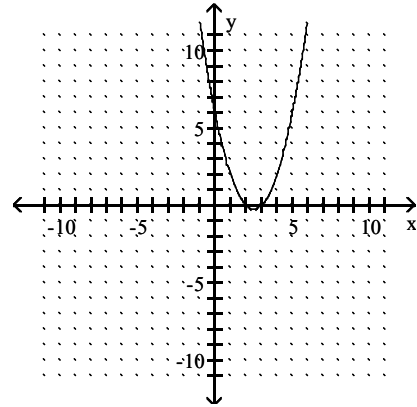

C) Vertex:  $\left(-\frac{5}{2}, -\frac{1}{4}\right)$

x-intercepts: -3 and -2

y-intercept: 6

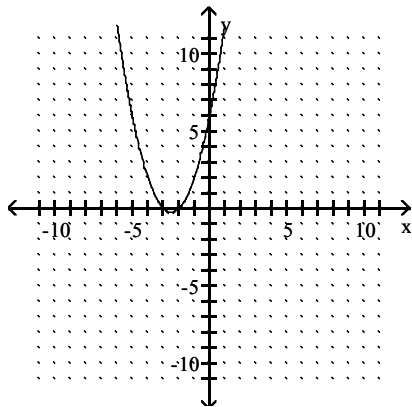

D) Vertex:  $\left(-\frac{5}{2}, -\frac{1}{4}\right)$

x-intercepts: 3 and 2

y-intercept: 6

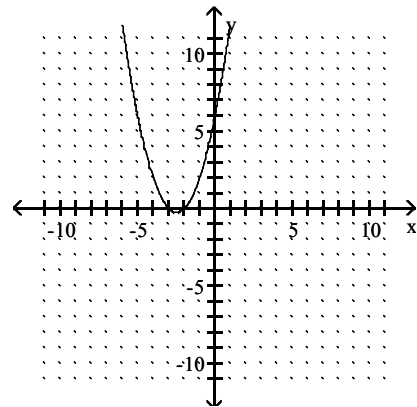

Answer: C

37)  $y = -2x + x^2 + 6$

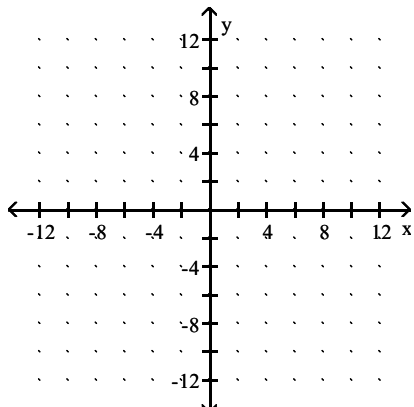

A) Vertex:  $\left(\frac{7}{2}, \frac{25}{4}\right)$

x-intercepts: 1 and 6

y-intercept: 6

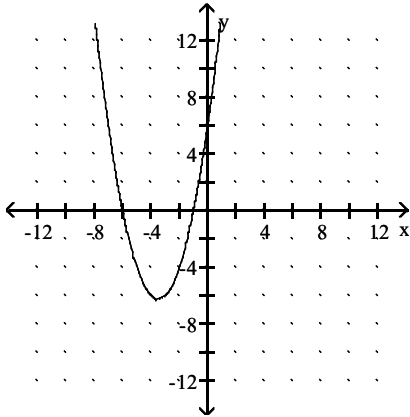

B) Vertex:  $(1, -5)$

x-intercepts: none

y-intercept: -6

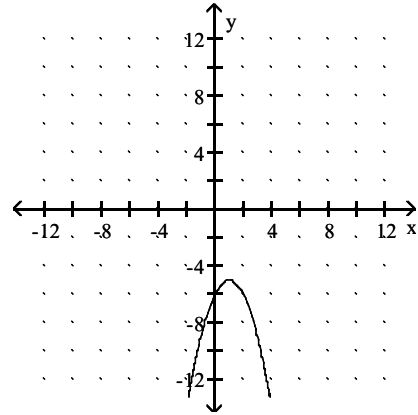

C) Vertex:  $(1, 5)$

x-intercepts: none

y-intercept: 6

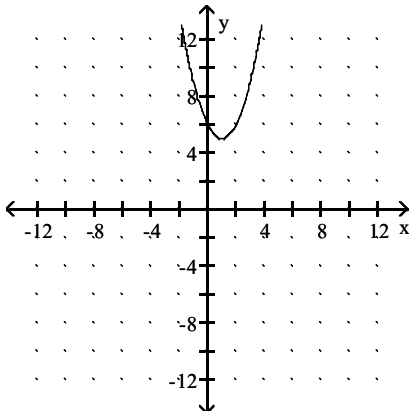

D) Vertex:  $(1, -1)$

x-intercepts: 0 and 2

y-intercept: 0

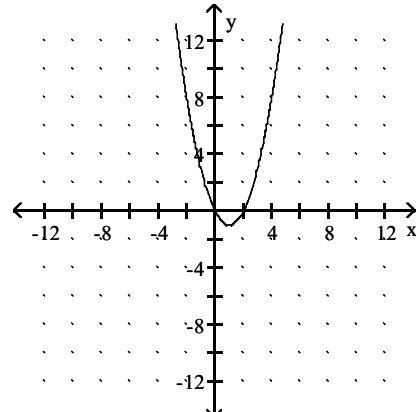

Answer: C

38)  $y = -x^2 - 2x - 1$

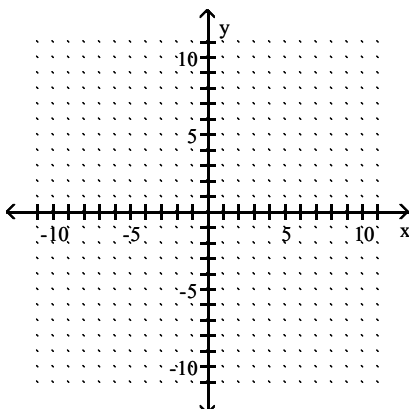

A) Vertex: (1, 0)  
 x-intercept: 1  
 y-intercept: 1

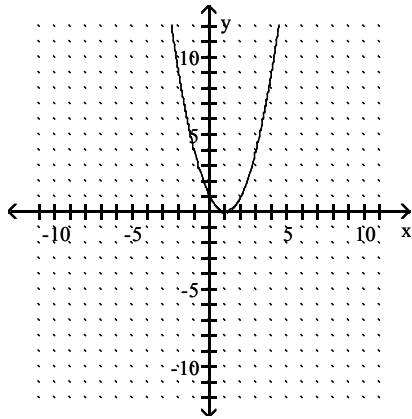

B) Vertex: (1, 0)  
 x-intercept: 1  
 y-intercept: -1

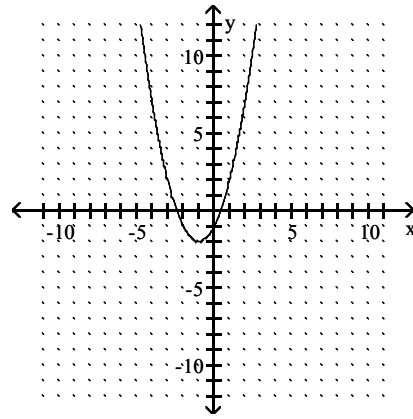

C) Vertex: (-1, 0)  
 x-intercept: -1  
 y-intercept: -1

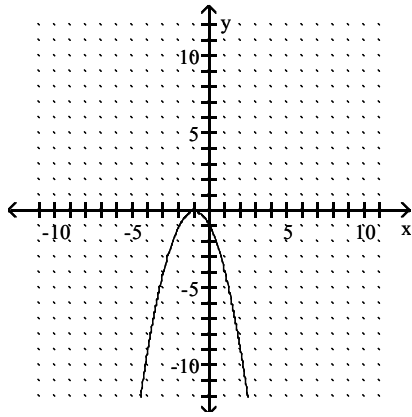

D) Vertex: (-1, 0)  
 x-intercept: -1  
 y-intercept: 1

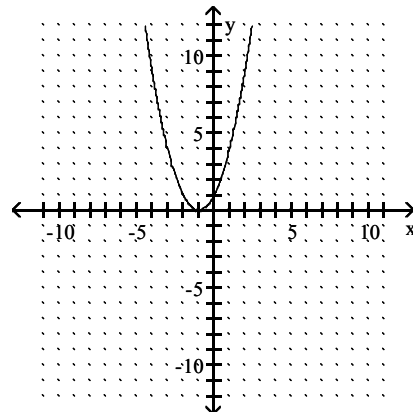

Answer: C

39)  $y = -3x^2 + 24x - 50$

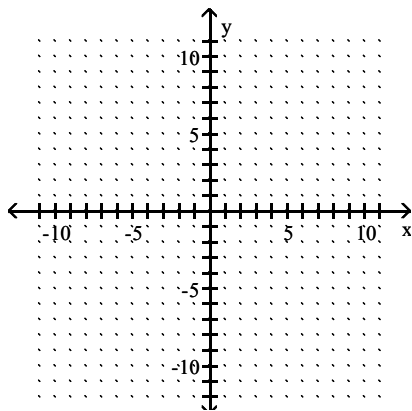

- A) Vertex  $(-4, -2)$   
 x-intercepts: none  
 y-intercept  $-\frac{22}{3}$

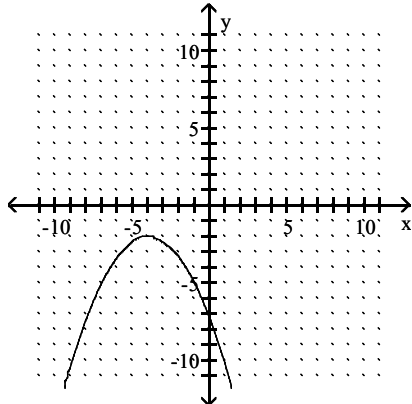

- B) Vertex  $(-4, -2)$   
 x-intercepts: none  
 y-intercept:  $-50$

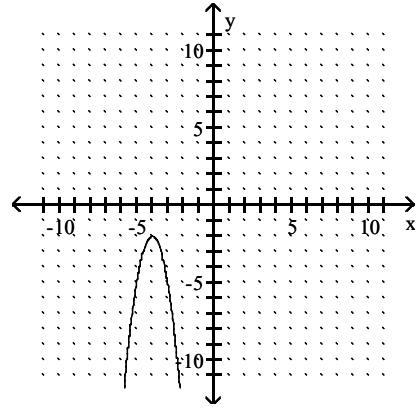

- C) Vertex  $(4, -2)$   
 x-intercepts: none  
 y-intercept:  $-\frac{22}{3}$

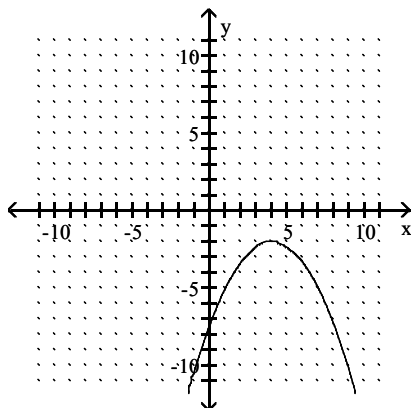

- D) Vertex:  $(4, -2)$   
 x-intercepts: none  
 y-intercept:  $-50$

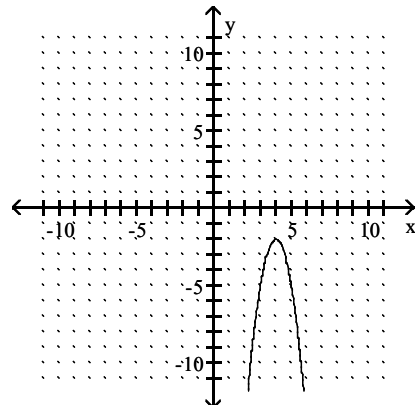

Answer: D

40)  $y = -5x - 7 + 2x^2$

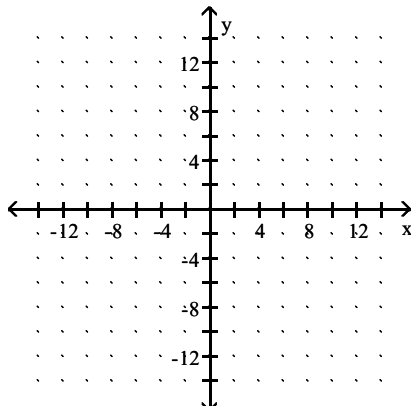

A) Vertex:  $\left(-\frac{5}{4}, -\frac{81}{8}\right)$

x-intercepts: 1 and  $-\frac{7}{2}$

y-intercept: -7

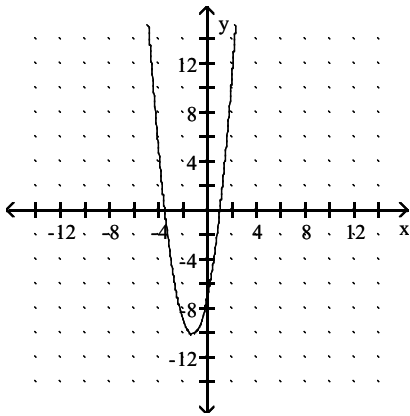

B) Vertex:  $\left(\frac{5}{4}, -\frac{81}{8}\right)$

x-intercepts: -1 and  $\frac{7}{2}$

y-intercept: -7

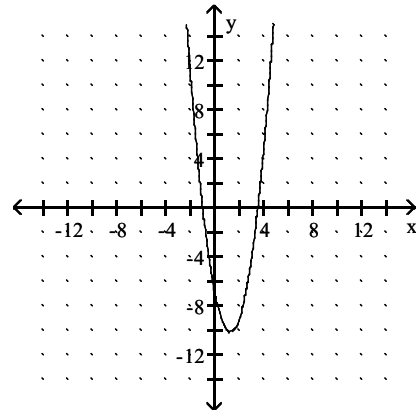

C) Vertex:  $(3, -16)$

x-intercepts: -1 and 7

y-intercept: -7

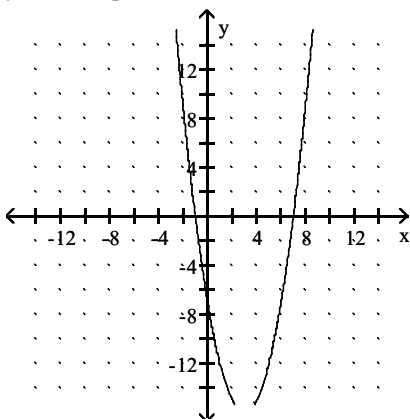

D) Vertex:  $\left(\frac{5}{4}, \frac{81}{8}\right)$

x-intercepts: -1 and  $\frac{7}{2}$

y-intercept: 0, 7

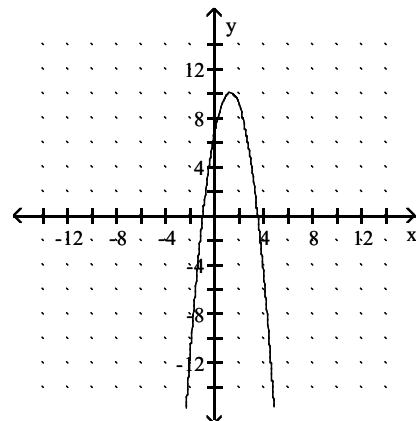

Answer: B

Find the axis of symmetry of the given function.

41)  $y = x^2 - 14x + 54$

A)  $x = 0$

B)  $x = 5$

C)  $x = -7$

D)  $x = 7$

Answer: D

42)  $f(x) = -9x + x^2 + 4$

A)  $x = \frac{9}{2}$

B)  $x = \frac{9}{4}$

C)  $x = -\frac{9}{2}$

D)  $x = 9$

Answer: A



43)  $f(x) = -3x^2 + 4x$

A)  $x = -1$

B)  $x = \frac{2}{3}$

C)  $x = -\frac{1}{3}$

D)  $x = -2$

Answer: B

44)  $f(x) = 5x - 1 - x^2$

A)  $x = -\frac{5}{2}$

B)  $x = \frac{5}{2}$

C)  $x = 5$

D)  $x = \frac{5}{8}$

Answer: B

45)  $y = 2x^2 + 20x + 54$

A)  $x = 5$

B)  $x = -5$

C)  $x = -4$

D)  $x = 4$

Answer: B

46)  $y = 3x^2 + 6x - 2$

A)  $x = 1$

B)  $x = -1$

C)  $x = 5$

D)  $x = -5$

Answer: B

47)  $y = -2x^2 - 16x - 33$

A)  $x = 4$

B)  $x = -1$

C)  $x = -4$

D)  $x = 1$

Answer: C

48)  $y = 9x^2 - 72x + 145$

A)  $x = 4$

B)  $x = 1$

C)  $x = 0$

D)  $x = -1$

Answer: A

49)  $f(x) = 17x - 2x^2 + 7$

A)  $x = \frac{17}{4}$

B)  $x = \frac{17}{2}$

C)  $x = -\frac{17}{4}$

D)  $x = -\frac{17}{2}$

Answer: A

50)  $f(x) = 5 - 2x^2 + 9x$

A)  $x = \frac{9}{8}$

B)  $x = -\frac{9}{2}$

C)  $x = \frac{9}{4}$

D)  $x = -\frac{9}{8}$

Answer: C

**Determine whether there is a maximum or minimum value for the given function, and find that value.**

51)  $f(x) = x^2 - 12x + 46$

A) Maximum: -10

B) Maximum: 6

C) Minimum: 0

D) Minimum: 10

Answer: D

52)  $f(x) = x^2 + 20x + 90$

A) Minimum: -10

B) Maximum: 10

C) Maximum: -10

D) Minimum: 0

Answer: A

53)  $f(x) = -2x - x^2 - 3$   
 A) Maximum: -2                      B) Minimum: 0                      C) Maximum: 2                      D) Minimum: 2  
 Answer: A

54)  $f(x) = -658 - 8x^2 - 144x$   
 A) Maximum: 10                      B) Minimum: 10                      C) Maximum: -10                      D) Minimum: 0  
 Answer: C

55)  $f(x) = x^2 + 12x + 32$   
 A) Minimum: -6                      B) Maximum: -4                      C) Minimum: -4                      D) Maximum: 0  
 Answer: C

**Find the range of the given function.**

56)  $f(x) = 2x^2 + 8x + 4$   
 A)  $[-4, \infty)$                       B)  $[-2, \infty)$                       C)  $(-\infty, 4]$                       D)  $(-\infty, 2]$   
 Answer: A

57)  $f(x) = 2x^2 + 12x + 17$   
 A)  $[-1, \infty)$                       B)  $(-\infty, 3]$                       C)  $(-\infty, 1]$                       D)  $[-3, \infty)$   
 Answer: A

58)  $f(x) = -4x^2 - 32x - 70$   
 A)  $(-\infty, -4]$                       B)  $(-\infty, -6]$                       C)  $[4, \infty)$                       D)  $[6, \infty)$   
 Answer: B

59)  $f(x) = -4x + x^2 + 8$   
 A)  $(-\infty, 0]$                       B)  $[-2, \infty)$                       C)  $[4, \infty)$                       D)  $[2, \infty)$   
 Answer: C

60)  $f(x) = -5x^2 + 50x - 123$   
 A)  $[-2, \infty)$                       B)  $(-\infty, 2]$                       C)  $[-5, \infty)$                       D)  $(-\infty, -5]$   
 Answer: B

**Solve the quadratic inequality by sketching the graph of the corresponding quadratic function.**

61)  $x^2 - 9 \geq 0$

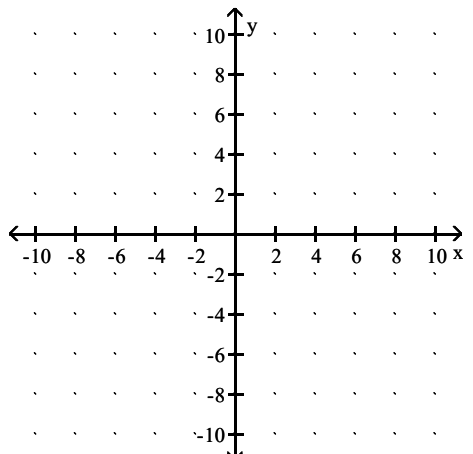

A) Solution:  $(-\infty, -3) \cup (3, \infty)$

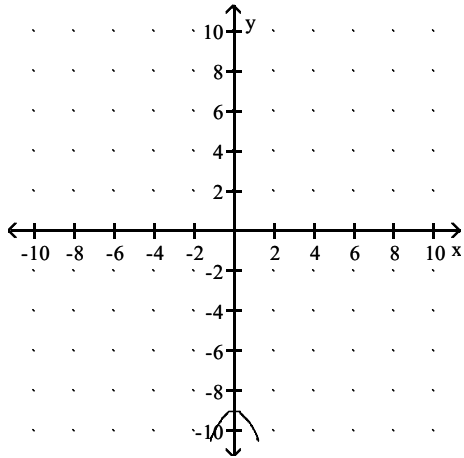

B) Solution:  $(-\infty, -3] \cup [3, \infty)$

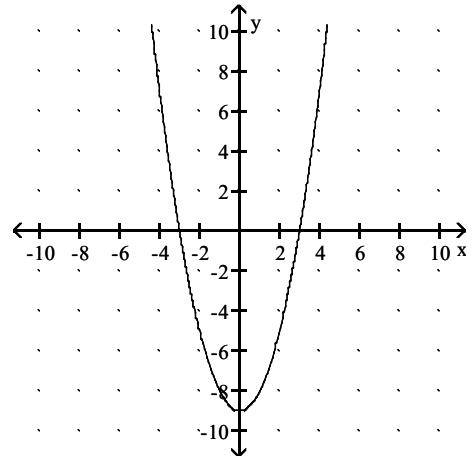

C) Solution:  $(-\infty, -3) \cup (3, \infty)$

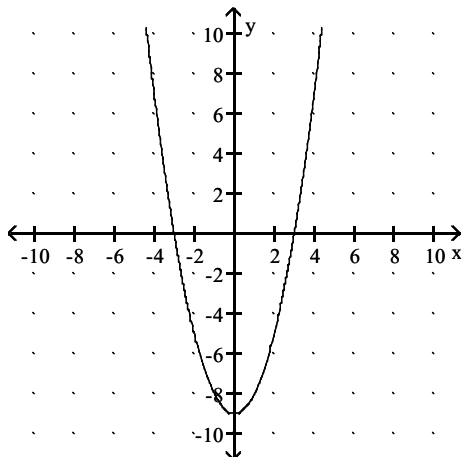

D) Solution:  $[-3, 3]$

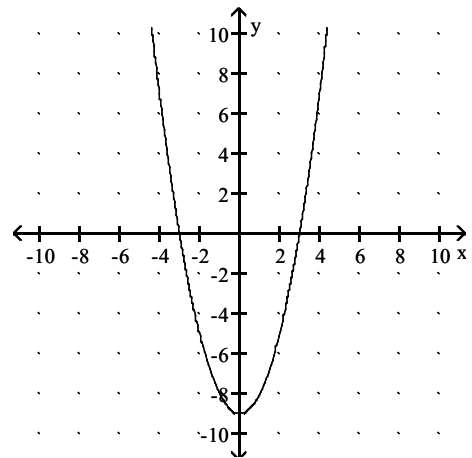

Answer: B

62)  $x^2 + 5x + 9 < 0$

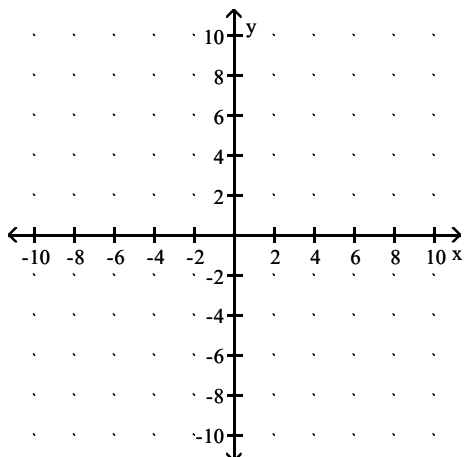

A) Solution:  $\emptyset$

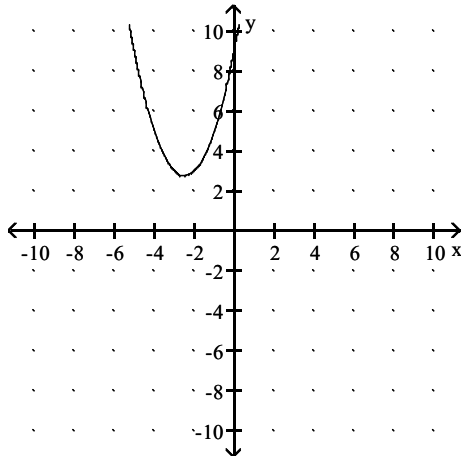

B) Solution:  $[0, \infty)$

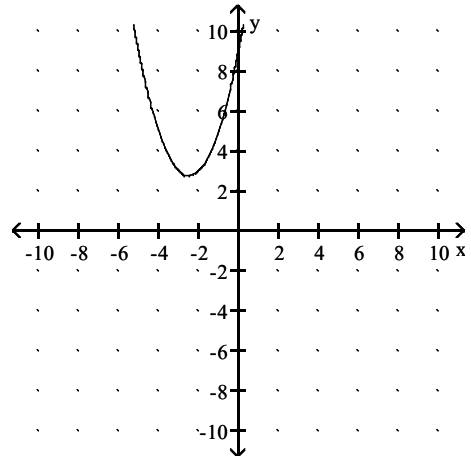

C) Solution:  $(-\infty, \infty)$

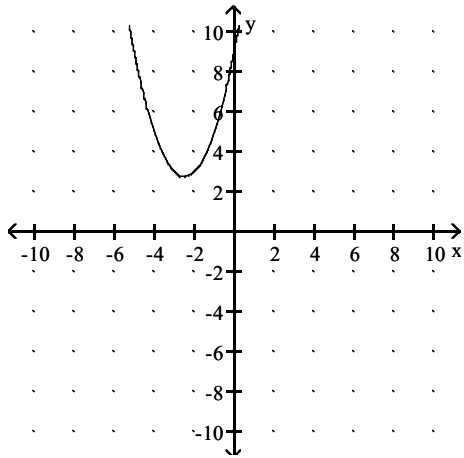

D) Solution:  $(-\infty, 0)$

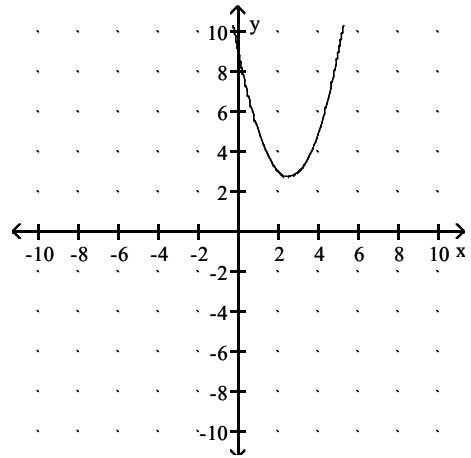

Answer: A

63)  $x^2 - 8x + 15 < 0$

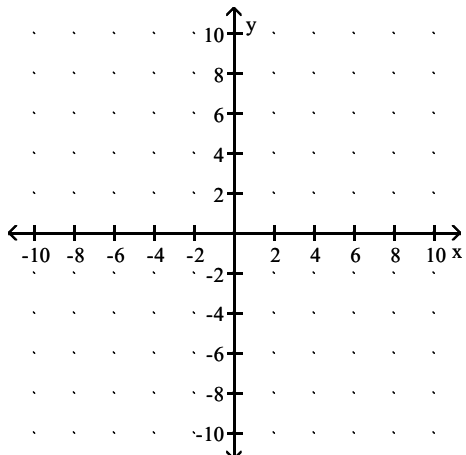

A) Solution:  $[3, 5]$

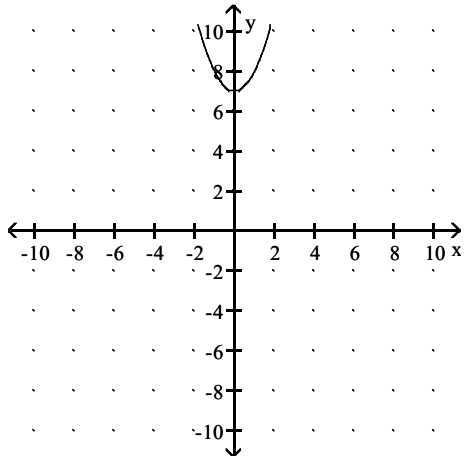

B) Solution:  $(3, 5)$

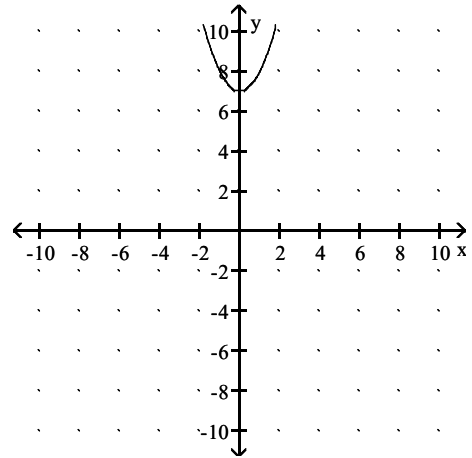

C) Solution:  $\emptyset$

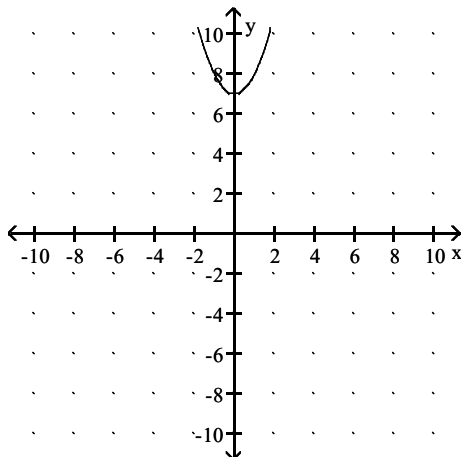

D) Solution:  $(-\infty, 3) \cup (5, \infty)$

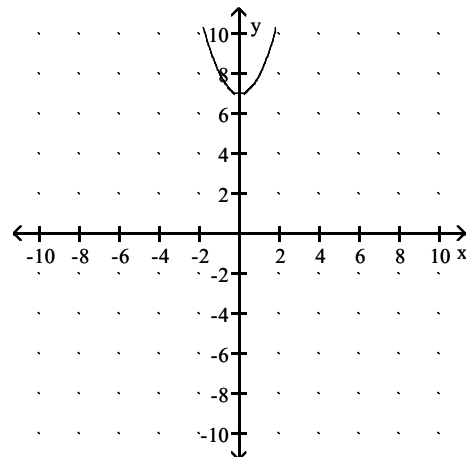

Answer: B

64)  $x^2 + 4x - 32 > 0$

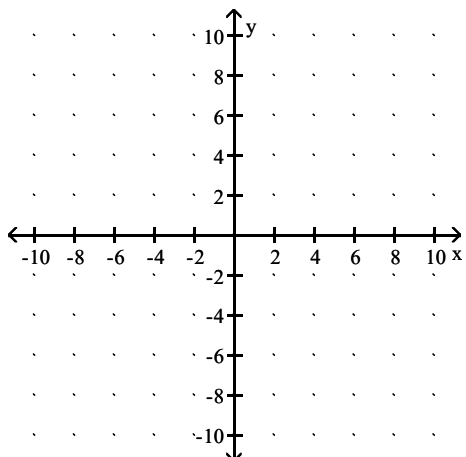

A) Solution:  $(-\infty, -8) \cup (4, \infty)$

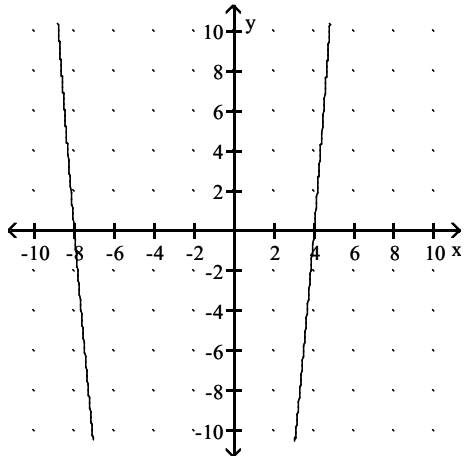

B) Solution:  $(-8, 4)$

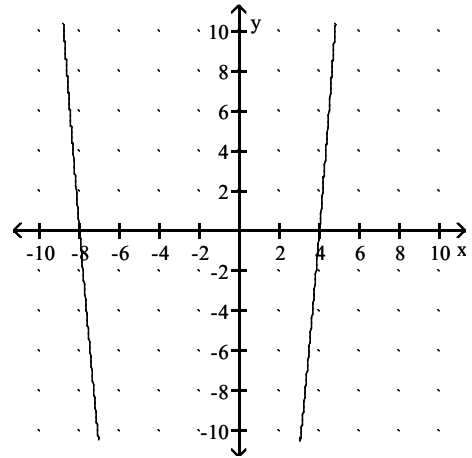

C) Solution:  $\emptyset$

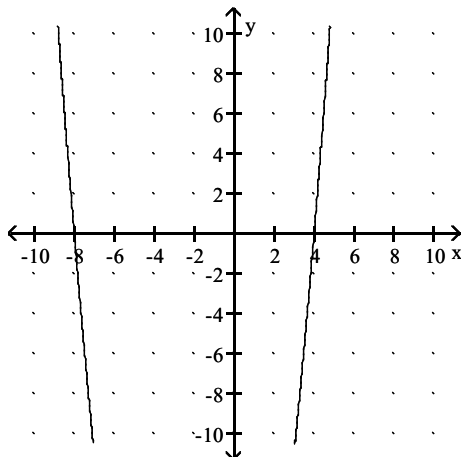

D) Solution:  $(-\infty, -8] \cup [4, \infty)$

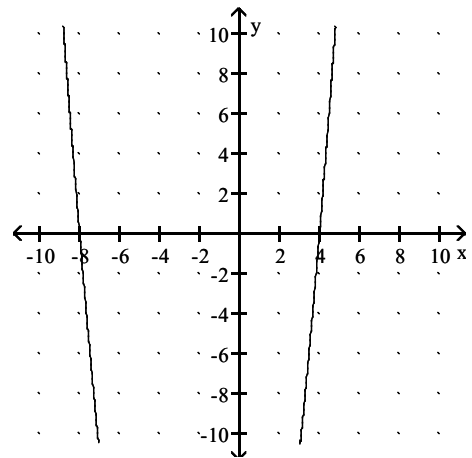

Answer: A

65)  $-5x^2 + 34x - 24 \geq 0$

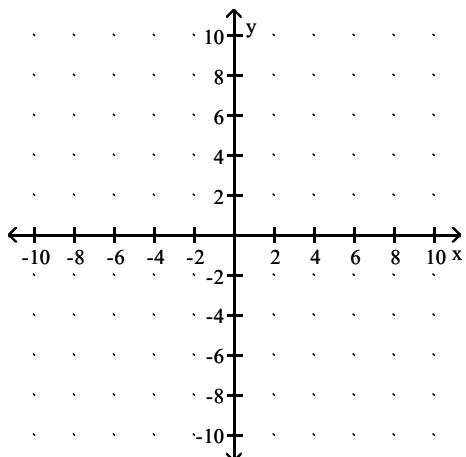

A) Solution:  $\emptyset$

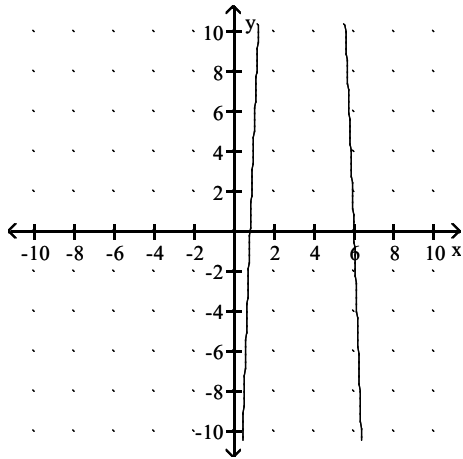

B) Solution:  $(-\infty, \frac{4}{5}] \cup [6, \infty)$

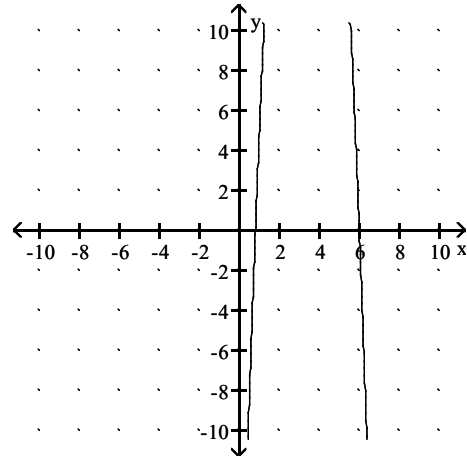

C) Solution:  $[\frac{4}{5}, 6]$

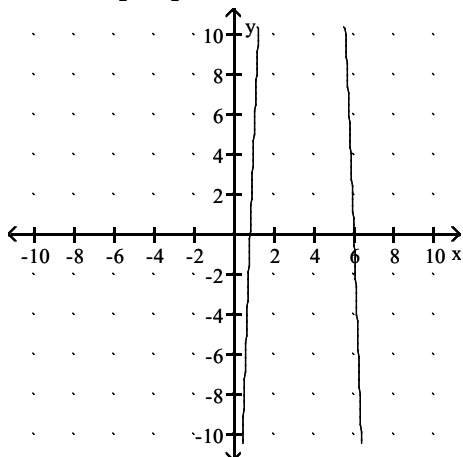

D) Solution: (0, 6)

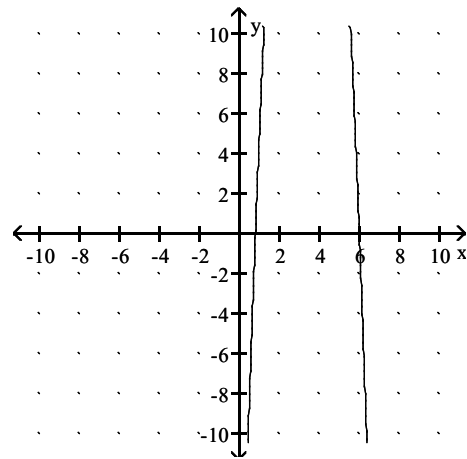

Answer: C

**Solve the problem.**

66) The length and width of a rectangle have a sum of 70. What dimensions give the maximum area?

- A) Length 25 and width 45
- C) Length 26 and width 44

- B) Length 35 and width 35
- D) Length 34 and width 36

Answer: B

67) The number of mosquitoes  $M(x)$ , in millions, in a certain area depends on the June rainfall  $x$ , in inches:

$M(x) = 4x - x^2$ . What rainfall produces the maximum number of mosquitoes?

- A) 2 in.
- B) 0 in.
- C) 4 in.
- D) 16 in.

Answer: A

68) John owns a hotdog stand. He has found that his profit is represented by the equation  $P = -x^2 + 64x + 73$ , with  $P$  being profits and  $x$  the number of hotdogs. How many hotdogs must he sell to earn the most profit?

- A) 32 hotdogs
- B) 33 hotdogs
- C) 41 hotdogs
- D) 20 hotdogs

Answer: A

69) If an object is propelled upward from a height of 48 feet at an initial velocity of 32 feet per second, then its height  $h$  after  $t$  seconds is given by the equation  $h = -16t^2 + 32t + 48$ . After how many seconds does the object hit the ground?

- A) 1.5 sec                                      B) 3 sec                                      C) 11 sec                                      D) 2.0 sec

Answer: B

70) A rock is propelled upward from the top of a building 110 feet tall at an initial velocity of 200 feet per second. The function that describes the height of the rocket in terms of time  $t$  is  $f(t) = -16t^2 + 200t + 110$ . Determine the time at which the rock reaches its maximum height.

- A) 5 sec                                      B) 12.5 sec                                      C) 10 sec                                      D) 6.25 sec

Answer: D

71) A rock is propelled upward from the top of a building 170 feet tall at an initial velocity of 176 feet per second. The function that describes the height of the rocket in terms of time  $t$  is  $f(t) = -16t^2 + 176t + 170$ . Determine the maximum height that the rock reaches.

- A) 614 ft                                      B) 669 ft                                      C) 639 ft                                      D) 654 ft

Answer: D

72) A farmer has 800 feet of fence with which to fence a rectangular plot of land. The plot lies along a river so that only three sides need to be fenced. Estimate the largest area that can be fenced.

- A) 96,000 ft<sup>2</sup>                                      B) 120,000 ft<sup>2</sup>                                      C) 64,000 ft<sup>2</sup>                                      D) 80,000 ft<sup>2</sup>

Answer: D

73) An art teacher knows that for a price of \$28 per student, she can enroll 60 students in her pottery class. However, for each decrease of \$2 in the price, she can expect 10 more students. What price will maximize her revenue from the class?

- A) \$12                                      B) \$20                                      C) \$36                                      D) \$24

Answer: B

74) The stadium vending company finds that sales of hot dogs average 45,000 hot dogs per game when the hot dogs sell for \$2.50 each. For each 50 cent increase in the price, the sales per game drop by 5000 hot dogs. What price per hot dog should the vending company charge to realize the maximum revenue?

- A) \$2.00                                      B) \$3.50                                      C) \$4.50                                      D) \$3.75

Answer: B

75) The quadratic function  $f(x) = 0.0040x^2 - 0.41x + 36.94$  models the median, or average, age,  $y$ , at which U.S. men were first married  $x$  years after 1900. In which year was this average age at a minimum? (Round to the nearest year.) What was the average age at first marriage for that year? (Round to the nearest tenth.)

- A) 1951, 47.4 years old                                      B) 1952, 36 years old  
C) 1951, 26.4 years old                                      D) 1936, 47.4 years old

Answer: C



For those which are polynomial functions, find the degree, the leading term, and the leading coefficient.

76)  $f(x) = 7x^4 + 6x^2$

- A) Degree: 4, leading term:  $7x^4$ , leading coefficient: 7
- B) Degree: 4, leading term: 7, leading coefficient:  $7x^4$
- C) Degree: 7, leading term:  $x^4$ , leading coefficient: 7
- D) Degree: 2, leading term:  $7x^4$ , leading coefficient: 7

Answer: A

77)  $f(x) = 3 + 5x - 7x^3$

- A) Degree: 0, leading term: 3, leading coefficient: 3
- B) Degree: 3, leading term:  $-7$ , leading coefficient: 3
- C) Degree: 3, leading term:  $-7x^3$ , leading coefficient:  $-7$
- D) not a polynomial function

Answer: C

78)  $f(x) = 4x^4 + 8 - 2\sqrt{2}x^7$

- A) Degree: 7, leading term:  $2\sqrt{2}x^7$ , leading coefficient:  $2\sqrt{2}$
- B) Degree: 7, leading term:  $-2\sqrt{2}x^7$ , leading coefficient:  $-2\sqrt{2}$
- C) Degree: 4, leading term:  $-2\sqrt{2}x^7$ , leading coefficient:  $-2\sqrt{2}$
- D) not a polynomial function

Answer: B

79)  $f(x) = -5$

- A) Degree: 0, leading term:  $-5x$ , leading coefficient:  $-5$
- B) not a polynomial function
- C) Degree: 0, leading term:  $-5$ , leading coefficient:  $-5$
- D) Degree: 1, leading term:  $-5$ , leading coefficient:  $-5$

Answer: C

**SHORT ANSWER. Write the word or phrase that best completes each statement or answers the question.**

**Explain why the function is not a polynomial function.**

80)  $f(x) = \frac{x^5 - 9}{x^6 - 1}$

Answer: Division by a polynomial is not allowed

81)  $f(x) = x^{3/2} - x^5 - 1$

Answer: Noninteger exponent

82)  $f(x) = 5x^3 + 4x^2 - 5x^{-2} + 16$

Answer: Negative exponent

83)  $f(x) = x^2 - 3|x| + 8$

Answer: Presence of  $|x|$

84)  $f(x) = 2x^4 + 4x^2, 0 \leq x \leq 5$

Answer: Domain not  $(-\infty, \infty)$

85)  $f(x) = \begin{cases} 4x - 6, & x \neq 2 \\ 0, & x = 2 \end{cases}$

Answer: Graph is not continuous

**MULTIPLE CHOICE. Choose the one alternative that best completes the statement or answers the question.**

**Determine whether the graph shown is the graph of a polynomial function.**

86)

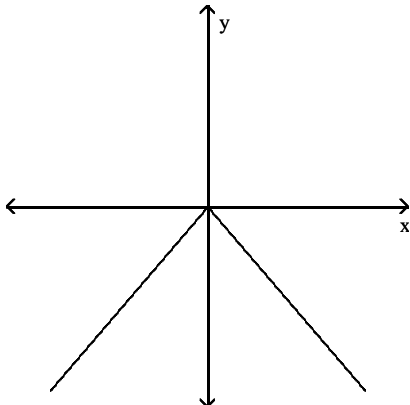

A) polynomial function

B) not a polynomial function

Answer: B

87)

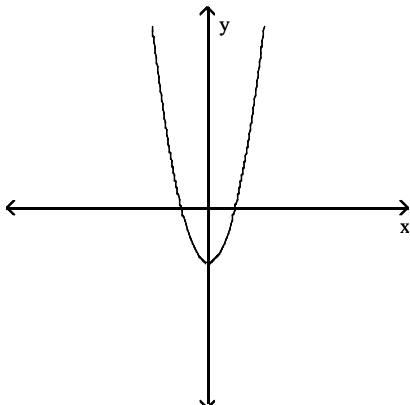

A) polynomial function

B) not a polynomial function

Answer: A

88)

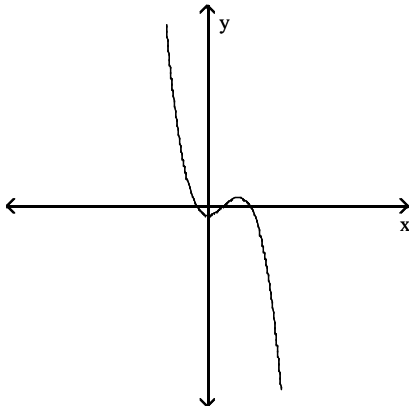

A) polynomial function

Answer: A

B) not a polynomial function

89)

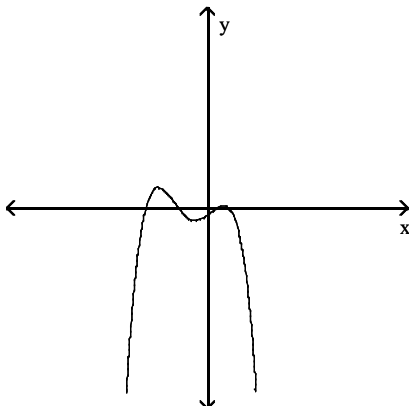

A) polynomial function

Answer: A

B) not a polynomial function

90)

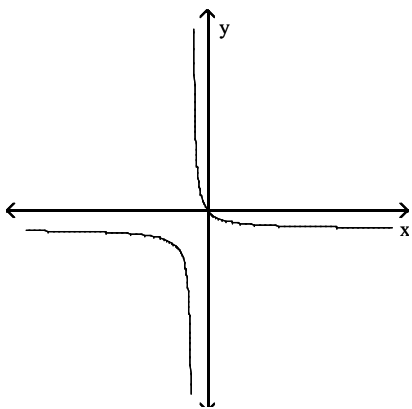

A) polynomial function

Answer: B

B) not a polynomial function

91)

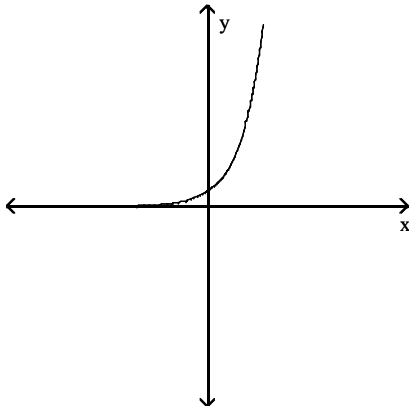

A) polynomial function

B) not a polynomial function

Answer: B

Find the equation that the given graph represents.

92)

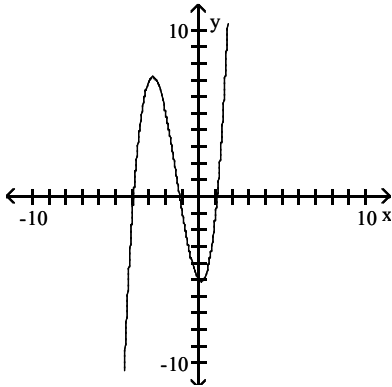

A)  $f(x) = x^2 + 4x - 5$

B)  $f(x) = x^3 + 4x^2 - x - 5$

C)  $f(x) = -x^3 + 4x^2 + x - 5$

D)  $f(x) = x^3 + x^2 + x + 5$

Answer: B

93)

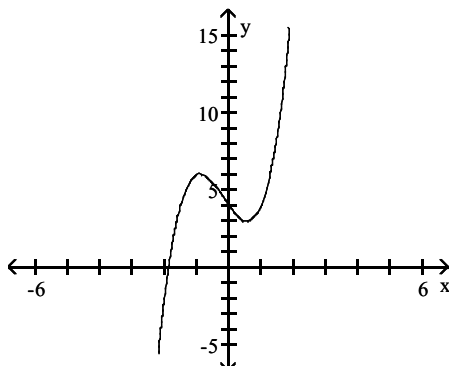

A)  $f(x) = -x^3 - x - 4$

B)  $f(x) = 2x^4 - x^2 + 4$

C)  $f(x) = 2x^3 + x^2 - 3x + 4$

D)  $f(x) = -x^4 + x^2 - 3x - 4$

Answer: C

94)

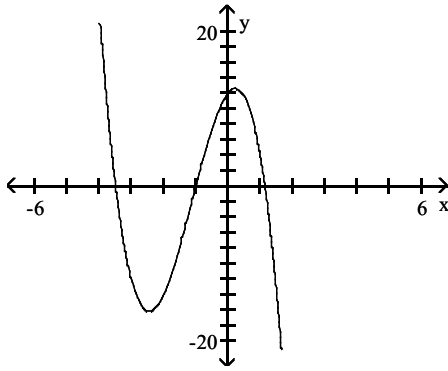

A)  $f(x) = 2x^3 - 12x^2 - 5x - 12$

C)  $f(x) = -3x^3 - 10x^2 + 5x + 12$

B)  $f(x) = 3x^2 - 5x + 12$

D)  $f(x) = x^4 - 2x^2 - 3x + 12$

Answer: C

95)

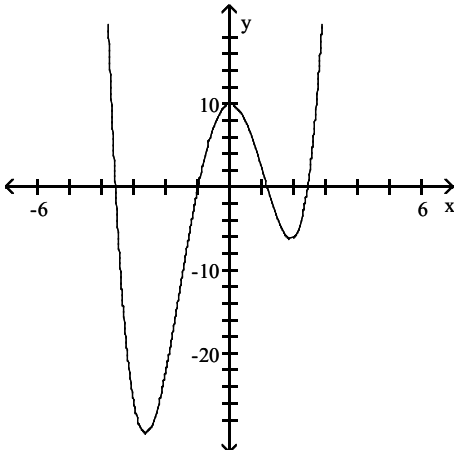

A)  $f(x) = -x^3 - 12x^2 + 3x + 10$

C)  $f(x) = x^3 - 10x^2 - x + 10$

B)  $f(x) = -x^4 + x^3 - 12x^2 + 10$

D)  $f(x) = x^4 + x^3 - 10x^2 + 10$

Answer: D

96)

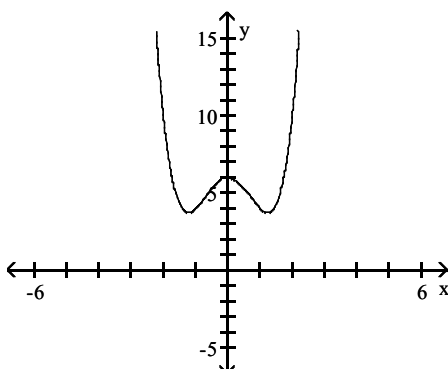

A)  $f(x) = -x^4 + 3x^2 + 6$

C)  $f(x) = -x^3 - 6x^2 - x + 6$

B)  $f(x) = x^4 - 3x^2 + 6$

D)  $f(x) = (x + 6)^4$

Answer: B

97)

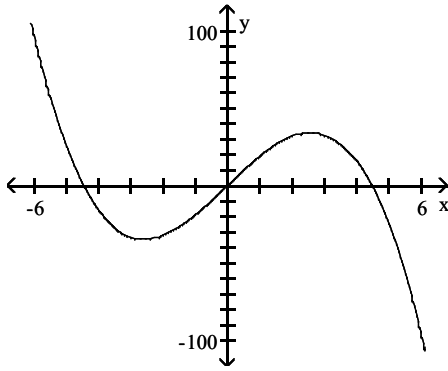

A)  $f(x) = x^3 + 9x$

C)  $f(x) = -x^3 + 4x^2 - 9$

B)  $f(x) = x^3 - 4x^2 + 20x$

D)  $f(x) = -x^3 + 20x$

Answer: D

**Find the y-intercept of the polynomial function.**

98)  $f(x) = 7x - x^3$

A) -1

B) -7

C) 0

D) 7

Answer: C

99)  $f(x) = -x^2 - 2x + 3$

A) 0

B) 3

C) -1

D) -3

Answer: B

100)  $f(x) = (x + 1)(x - 5)(x - 1)^2$

A) -1

B) 0

C) 5

D) -5

Answer: D

101)  $f(x) = -x^2(x + 2)(x^2 - 1)$

A) -1

B) -2

C) 2

D) 0

Answer: D

102)  $f(x) = -x^2(x + 6)(x^2 + 1)$

A) 0

B) -6

C) 1

D) 6

Answer: A

103)  $f(x) = x^2(x - 4)(x - 5)$

A) 0

B) -20

C) -4

D) 20

Answer: A

104)  $f(x) = -x^2(x + 3)(x - 7)$

A) -21

B) 21

C) 0

D) -7

Answer: C

105)  $f(x) = (x - 2)^2(x^2 - 9)$

A) 36

B) -18

C) -36

D) 18

Answer: C

Find the zeros of the polynomial function and state the multiplicity of each.

106)  $f(x) = (x + 3)^2(x - 1)$

- A)  $x = 3$ , multiplicity 2;  $x = 1$ , multiplicity 1  
C)  $x = -3$ , multiplicity 1;  $x = 1$ , multiplicity 2

- B)  $x = -3$ , multiplicity 1;  $x = 1$ , multiplicity 1  
D)  $x = -3$ , multiplicity 2;  $x = 1$ , multiplicity 1

Answer: D

107)  $f(x) = 5(x + 9)^2(x - 9)^3$

- A)  $x = -9$ , multiplicity 3;  $x = 9$ , multiplicity 2  
B)  $x = 4$ , multiplicity 1;  $x = -9$ , multiplicity 3;  $x = 9$ , multiplicity 3  
C)  $x = 4$ , multiplicity 1;  $x = 9$ , multiplicity 1;  $x = -9$ , multiplicity 1  
D)  $x = -9$ , multiplicity 2;  $x = 9$ , multiplicity 3

Answer: D

108)  $f(x) = -6x^2(x - 7)(x + 2)^3$

- A)  $x = -2$ , multiplicity 3;  $x = 7$ , multiplicity 1  
B)  $x = -2$ , multiplicity 3;  $x = 0$ , multiplicity 2;  $x = 2$ , multiplicity 1;  $x = 7$ , multiplicity 1  
C)  $x = -2$ , multiplicity 3;  $x = 0$ , multiplicity 2;  $x = 7$ , multiplicity 1  
D)  $x = -2$ , multiplicity 1;  $x = 2$ , multiplicity 1;  $x = 7$ , multiplicity 1

Answer: C

109)  $f(x) = 3x(x - 5)(x + 12)\left(x - \frac{1}{2}\right)$

- A)  $x = -5$ , multiplicity 1;  $x = -\frac{1}{2}$ , multiplicity 1;  $x = 12$ , multiplicity 1  
B)  $x = -5$ , multiplicity 1;  $x = -\frac{1}{2}$ , multiplicity 1;  $x = 0$ , multiplicity 1;  $x = 12$ , multiplicity 1  
C)  $x = -12$ , multiplicity 1;  $x = \frac{1}{2}$ , multiplicity 1;  $x = 5$ , multiplicity 1  
D)  $x = -12$ , multiplicity 1;  $x = 0$ , multiplicity 1;  $x = \frac{1}{2}$ , multiplicity 1;  $x = 5$ , multiplicity 1

Answer: D

110)  $f(x) = (x^2 - 1)^3$

- A)  $x = 1$ , multiplicity 5;  $x = -1$ , multiplicity 5  
C)  $x = 1$ , multiplicity 3;  $x = -1$ , multiplicity 3  
B)  $x = 1$ , multiplicity 3  
D)  $x = -1$ , multiplicity 3

Answer: C

111)  $f(x) = (x^2 + 14x + 45)^2$

- A)  $x = 9$ , multiplicity 2;  $x = 5$ , multiplicity 2  
C)  $x = \sqrt{5}$ , multiplicity 2;  $x = -\sqrt{5}$ , multiplicity 2  
B)  $x = -\sqrt{5}$ , multiplicity 4  
D)  $x = -5$ , multiplicity 2;  $x = -9$ , multiplicity 2

Answer: D

112)  $f(x) = x^4 - 18x^2 + 32$

- A)  $x = -4$ , multiplicity 1;  $x = 4$ , multiplicity 1;  $x = -\sqrt{2}$ , multiplicity 1  
B)  $x = 16$ , multiplicity 1;  $x = 2$ , multiplicity 1  
C)  $x = 16$ , multiplicity 1;  $x = -\sqrt{2}$ , multiplicity 1;  $x = \sqrt{2}$ , multiplicity 1  
D)  $x = -4$ , multiplicity 1;  $x = 4$ , multiplicity 1;  $x = -\sqrt{2}$ , multiplicity 1;  $x = \sqrt{2}$ , multiplicity 1

Answer: D

113)  $f(x) = x^4 - 20x^2 + 64$

- A)  $x = 16$ , multiplicity 2;  $x = 2$ , multiplicity 1
- B)  $x = 16$ , multiplicity 1;  $x = 4$ , multiplicity 1
- C)  $x = 16$ , multiplicity 2;  $x = 4$ , multiplicity 2
- D)  $x = -4$ , multiplicity 1;  $x = 4$ , multiplicity 1;  $x = -2$ , multiplicity 1;  $x = 2$ , multiplicity 1

Answer: D

**Find the zeros of the polynomial function. State whether the graph crosses the x-axis, or touches the x-axis and turns around, at each intercept.**

114)  $f(x) = 3x^2 - x^3$

- A)  $x = 0$ , touches the x-axis and turns around;  
 $x = \sqrt{3}$ , crosses the x-axis;  
 $x = -\sqrt{3}$ , crosses the x-axis
- B)  $x = 0$ , touches the x-axis and turns around;  
 $x = 3$ , crosses the x-axis
- C)  $x = 0$ , touches the x-axis and turns around;  
 $x = 3$ , touches the x-axis and turns around
- D)  $x = 0$ , crosses the x-axis;  
 $x = \sqrt{3}$ , crosses the x-axis;  
 $x = -\sqrt{3}$ , crosses the x-axis

Answer: B

115)  $f(x) = x^4 - 121x^2$

- A)  $x = 0$ , touches the x-axis and turns around;  
 $x = 11$ , crosses the x-axis;  
 $x = -11$ , crosses the x-axis
- B)  $x = 0$ , touches the x-axis and turns around;  
 $x = 121$ , touches the x-axis and turns around
- C)  $x = 0$ , crosses the x-axis;  
 $x = 11$ , crosses the x-axis;  
 $x = -11$ , crosses the x-axis
- D)  $x = 0$ , touches the x-axis and turns around;  
 $x = 121$ , crosses the x-axis

Answer: A

116)  $x^4 + 5x^3 - 84x^2 = 0$

- A)  $x = 0$ , touches the x-axis and turns around;  
 $x = -12$ , crosses the x-axis;  
 $x = 7$ , crosses the x-axis
- B)  $x = 0$ , crosses the x-axis;  
 $x = -12$ , crosses the x-axis;  
 $x = 7$ , crosses the x-axis
- C)  $x = 0$ , touches the x-axis and turns around;  
 $x = 12$ , touches the x-axis and turns around;  
 $x = -7$ , touches the x-axis and turns around
- D)  $x = 0$ , touches the x-axis and turns around;  
 $x = 12$ , crosses the x-axis;  
 $x = -7$ , crosses the x-axis

Answer: A

117)  $f(x) = (x + 1)(x - 6)(x - 1)^2$

- A)  $x = 1$ , crosses the x-axis;  
 $x = -6$ , touches the x-axis and turns around;  
 $x = -1$ , touches the x-axis and turns around
- B)  $x = 1$ , crosses the x-axis;  
 $x = -6$ , crosses the x-axis;  
 $x = -1$ , touches the x-axis and turns around
- C)  $x = -1$ , crosses the x-axis;  
 $x = 6$ , crosses the x-axis;  
 $x = 1$ , touches the x-axis and turns around
- D)  $x = -1$ , crosses the x-axis;  
 $x = 6$ , crosses the x-axis;  
 $x = 1$ , crosses the x-axis

Answer: C



118)  $f(x) = -x^2(x + 8)(x^2 - 1)$

- A)  $x = 0$ , crosses the  $x$ -axis;  
 $x = -8$ , crosses the  $x$ -axis;  
 $x = -1$ , crosses the  $x$ -axis;  
 $x = 1$ , crosses the  $x$ -axis
- C)  $x = 0$ , touches the  $x$ -axis and turns around;  
 $x = -8$ , crosses the  $x$ -axis;  
 $x = -1$ , crosses the  $x$ -axis;  
 $x = 1$ , crosses the  $x$ -axis

Answer: C

- B)  $x = 0$ , touches the  $x$ -axis and turns around;  
 $x = -8$ , crosses the  $x$ -axis;  
 $x = 1$ , touches the  $x$ -axis and turns around
- D)  $x = 0$ , touches the  $x$ -axis and turns around;  
 $x = 8$ , crosses the  $x$ -axis;  
 $x = -1$ , touches the  $x$ -axis and turns around;  
 $x = 1$ , touches the  $x$ -axis and turns around

119)  $f(x) = -x^2(x + 3)(x^2 + 1)$

- A)  $x = 0$ , touches the  $x$ -axis and turns around;  
 $x = 3$ , crosses the  $x$ -axis
- C)  $x = 0$ , touches the  $x$ -axis and turns around;  
 $x = -3$ , crosses the  $x$ -axis

Answer: C

- B)  $x = 0$ , touches the  $x$ -axis and turns around;  
 $x = -3$ , crosses the  $x$ -axis;  
 $x = -1$ , crosses the  $x$ -axis;  
 $x = 1$ , crosses the  $x$ -axis;
- D)  $x = 0$ , touches the  $x$ -axis and turns around;  
 $x = -3$ , crosses the  $x$ -axis;  
 $x = -1$ , touches the  $x$ -axis and turns around

120)  $f(x) = x^2(x - 4)(x - 6)$

- A)  $x = 0$ , touches the  $x$ -axis and turns around;  
 $x = 4$ , crosses the  $x$ -axis;  
 $x = 6$ , crosses the  $x$ -axis
- C)  $x = 0$ , crosses the  $x$ -axis;  
 $x = 4$ , touches the  $x$ -axis and turns around;  
 $x = 6$ , touches the  $x$ -axis and turns around

Answer: A

- B)  $x = 0$ , touches the  $x$ -axis and turns around;  
 $x = -4$ , crosses the  $x$ -axis;  
 $x = -6$ , crosses the  $x$ -axis
- D)  $x = 0$ , crosses the  $x$ -axis;  
 $x = 4$ , crosses the  $x$ -axis;  
 $x = 6$ , crosses the  $x$ -axis

121)  $f(x) = -x^3(x + 3)^2(x - 9)$

- A)  $x = 0$ , touches the  $x$ -axis and turns around;  
 $x = -3$ , touches the  $x$ -axis and turns around;  
 $x = 9$ , crosses the  $x$ -axis
- C)  $x = 0$ , touches the  $x$ -axis and turns around;  
 $x = 3$ , crosses the  $x$ -axis;  
 $x = 9$ , crosses the  $x$ -axis

Answer: B

- B)  $x = 0$ , crosses the  $x$ -axis;  
 $x = -3$ , touches the  $x$ -axis and turns around;  
 $x = 9$ , crosses the  $x$ -axis
- D)  $x = 0$ , crosses the  $x$ -axis;  
 $x = 3$ , touches the  $x$ -axis and turns around;  
 $x = -9$ , crosses the  $x$ -axis

122)  $f(x) = (x - 2)^2(x^2 - 25)$

- A)  $x = 2$ , touches the  $x$ -axis and turns around;  
 $x = -5$ , crosses the  $x$ -axis;  
 $x = 5$ , crosses the  $x$ -axis
- C)  $x = -2$ , touches the  $x$ -axis and turns around;  
 $x = 25$ , crosses the  $x$ -axis

Answer: A

- B)  $x = 2$ , touches the  $x$ -axis and turns around;  
 $x = 25$ , touches the  $x$ -axis and turns around
- D)  $x = 2$ , touches the  $x$ -axis and turns around;  
 $x = -5$ , touches the  $x$ -axis and turns around;  
 $x = 5$ , touches the  $x$ -axis and turns around

Determine the maximum possible number of turning points for the graph of the function.

123)  $f(x) = -x^2 - 14x + 13$

A) 0

B) 3

C) 2

D) 1

Answer: D

124)  $f(x) = (x - 4)(x - 7)(7x + 6)$

A) 7

B) 3

C) 2

D) 0

Answer: C

125)  $f(x) = x^2(x^2 - 6)(7x + 3)$

A) 28

B) 4

C) 2

D) 5

Answer: B

126)  $f(x) = (5x - 1)^4(x^4 + 2)(x + 4)$

A) 8

B) 45

C) 4

D) 9

Answer: A

127)  $f(x) = (x + 2)(x + 7)(x + 4)(x - 4)$

A) 3

B) 1

C) 0

D) 4

Answer: A

Use the Leading Coefficient Test to determine the end behavior of the polynomial function.

128)  $f(x) = 3x^3 + 4x^3 - x^5$

A)  $y \rightarrow \infty$  as  $x \rightarrow -\infty$  and  $y \rightarrow \infty$  as  $x \rightarrow \infty$

B)  $y \rightarrow -\infty$  as  $x \rightarrow -\infty$  and  $y \rightarrow \infty$  as  $x \rightarrow \infty$

C)  $y \rightarrow \infty$  as  $x \rightarrow -\infty$  and  $y \rightarrow -\infty$  as  $x \rightarrow \infty$

D)  $y \rightarrow -\infty$  as  $x \rightarrow -\infty$  and  $y \rightarrow -\infty$  as  $x \rightarrow \infty$

Answer: C

129)  $f(x) = x - 3x^2 - 2x^3$

A)  $y \rightarrow \infty$  as  $x \rightarrow -\infty$  and  $y \rightarrow -\infty$  as  $x \rightarrow \infty$

B)  $y \rightarrow -\infty$  as  $x \rightarrow -\infty$  and  $y \rightarrow -\infty$  as  $x \rightarrow \infty$

C)  $y \rightarrow -\infty$  as  $x \rightarrow -\infty$  and  $y \rightarrow \infty$  as  $x \rightarrow \infty$

D)  $y \rightarrow \infty$  as  $x \rightarrow -\infty$  and  $y \rightarrow \infty$  as  $x \rightarrow \infty$

Answer: A

130)  $f(x) = (x - 3)(x - 2)(x - 1)^2$

A)  $y \rightarrow \infty$  as  $x \rightarrow -\infty$  and  $y \rightarrow \infty$  as  $x \rightarrow \infty$

B)  $y \rightarrow -\infty$  as  $x \rightarrow -\infty$  and  $y \rightarrow \infty$  as  $x \rightarrow \infty$

C)  $y \rightarrow -\infty$  as  $x \rightarrow -\infty$  and  $y \rightarrow -\infty$  as  $x \rightarrow \infty$

D)  $y \rightarrow \infty$  as  $x \rightarrow -\infty$  and  $y \rightarrow -\infty$  as  $x \rightarrow \infty$

Answer: A

131)  $f(x) = (x + 1)(x + 3)(x + 5)^3$

A)  $y \rightarrow \infty$  as  $x \rightarrow -\infty$  and  $y \rightarrow \infty$  as  $x \rightarrow \infty$

B)  $y \rightarrow -\infty$  as  $x \rightarrow -\infty$  and  $y \rightarrow \infty$  as  $x \rightarrow \infty$

C)  $y \rightarrow \infty$  as  $x \rightarrow -\infty$  and  $y \rightarrow -\infty$  as  $x \rightarrow \infty$

D)  $y \rightarrow -\infty$  as  $x \rightarrow -\infty$  and  $y \rightarrow -\infty$  as  $x \rightarrow \infty$

Answer: B

132)  $f(x) = -5(x^2 + 2)(x - 3)^2$

A)  $y \rightarrow \infty$  as  $x \rightarrow -\infty$  and  $y \rightarrow \infty$  as  $x \rightarrow \infty$

B)  $y \rightarrow -\infty$  as  $x \rightarrow -\infty$  and  $y \rightarrow -\infty$  as  $x \rightarrow \infty$

C)  $y \rightarrow \infty$  as  $x \rightarrow -\infty$  and  $y \rightarrow -\infty$  as  $x \rightarrow \infty$

D)  $y \rightarrow -\infty$  as  $x \rightarrow -\infty$  and  $y \rightarrow \infty$  as  $x \rightarrow \infty$

Answer: B

133)  $f(x) = x^3(x - 4)(x - 3)^2$

A)  $y \rightarrow -\infty$  as  $x \rightarrow -\infty$  and  $y \rightarrow \infty$  as  $x \rightarrow \infty$

C)  $y \rightarrow \infty$  as  $x \rightarrow -\infty$  and  $y \rightarrow -\infty$  as  $x \rightarrow \infty$

Answer: D

B)  $y \rightarrow -\infty$  as  $x \rightarrow -\infty$  and  $y \rightarrow -\infty$  as  $x \rightarrow \infty$

D)  $y \rightarrow \infty$  as  $x \rightarrow -\infty$  and  $y \rightarrow \infty$  as  $x \rightarrow \infty$

134)  $f(x) = -x^2(x - 2)(x - 1)$

A)  $y \rightarrow -\infty$  as  $x \rightarrow -\infty$  and  $y \rightarrow \infty$  as  $x \rightarrow \infty$

C)  $y \rightarrow \infty$  as  $x \rightarrow -\infty$  and  $y \rightarrow -\infty$  as  $x \rightarrow \infty$

Answer: B

B)  $y \rightarrow -\infty$  as  $x \rightarrow -\infty$  and  $y \rightarrow -\infty$  as  $x \rightarrow \infty$

D)  $y \rightarrow \infty$  as  $x \rightarrow -\infty$  and  $y \rightarrow \infty$  as  $x \rightarrow \infty$

135)  $f(x) = -6x^3(x - 1)(x + 2)^2$

A)  $y \rightarrow \infty$  as  $x \rightarrow -\infty$  and  $y \rightarrow \infty$  as  $x \rightarrow \infty$

C)  $y \rightarrow -\infty$  as  $x \rightarrow -\infty$  and  $y \rightarrow \infty$  as  $x \rightarrow \infty$

Answer: B

B)  $y \rightarrow -\infty$  as  $x \rightarrow -\infty$  and  $y \rightarrow -\infty$  as  $x \rightarrow \infty$

D)  $y \rightarrow \infty$  as  $x \rightarrow -\infty$  and  $y \rightarrow \infty$  as  $x \rightarrow \infty$

**Graph the function.**

136)  $f(x) = -3x(x + 1)(x - 2)$

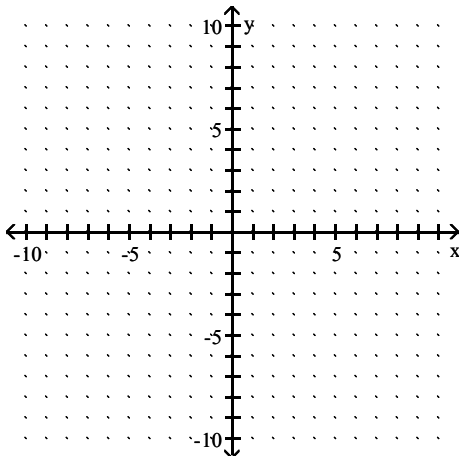

A)

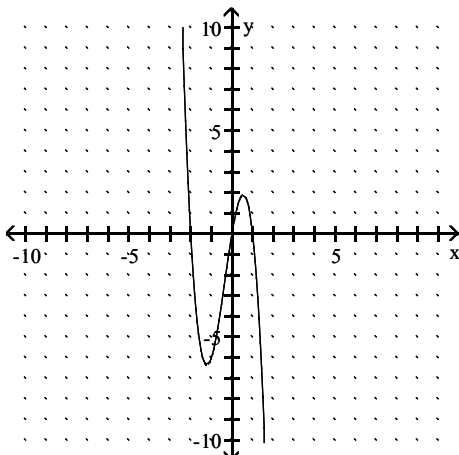

B)

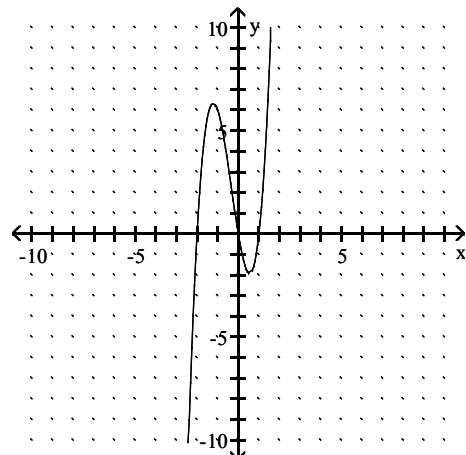

C)

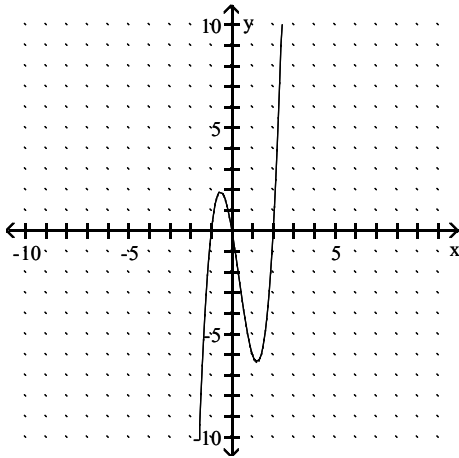

D)

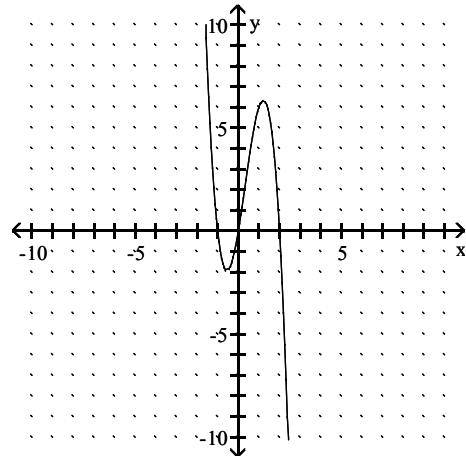

Answer: D

137)  $f(x) = x(x + 4)(x - 3)(x + 3)$

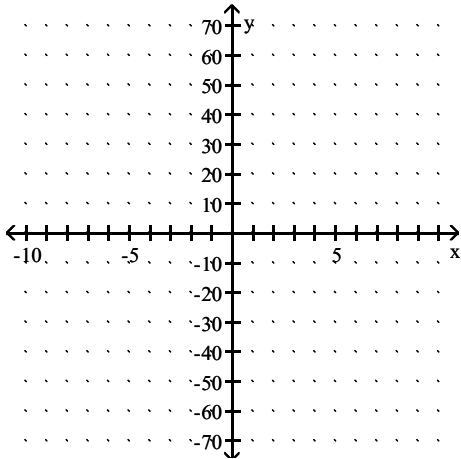

A)

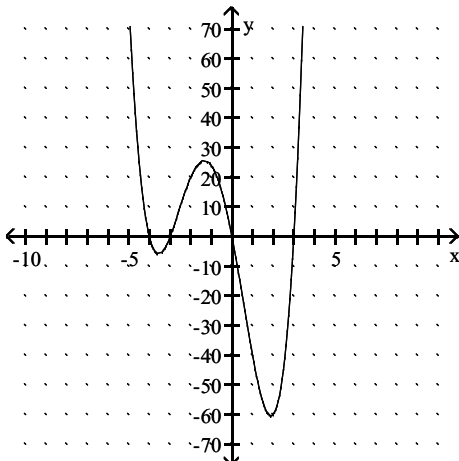

B)

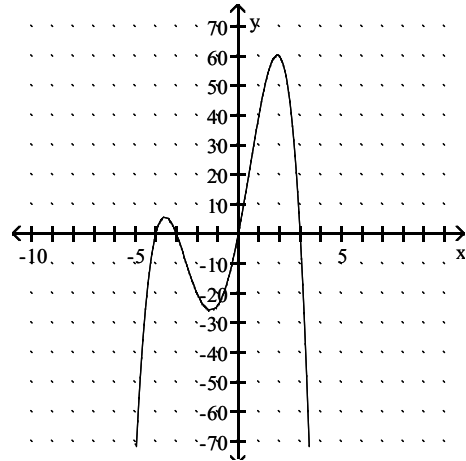

C)

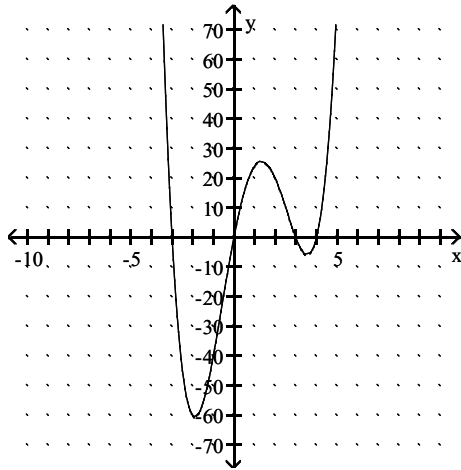

D)

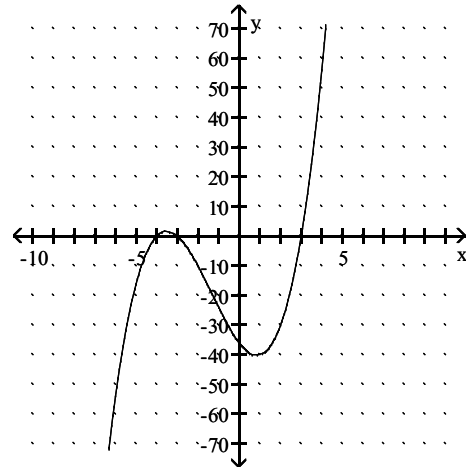

Answer: A

138)  $f(x) = x^3 - 3x^2$

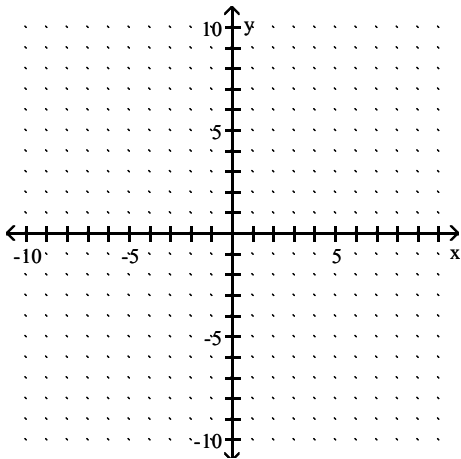

A)

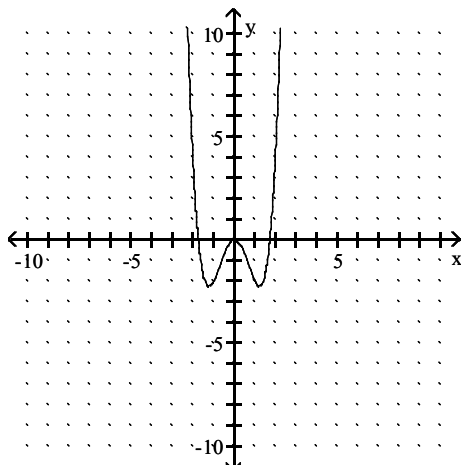

B)

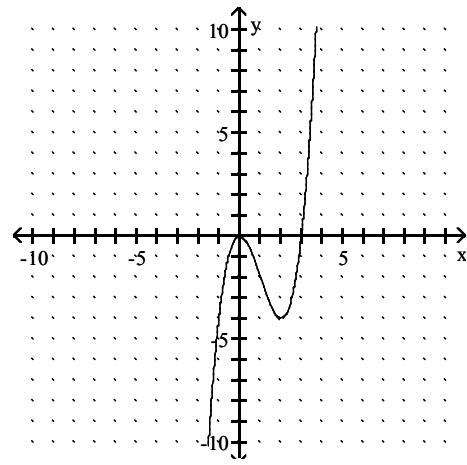

C)

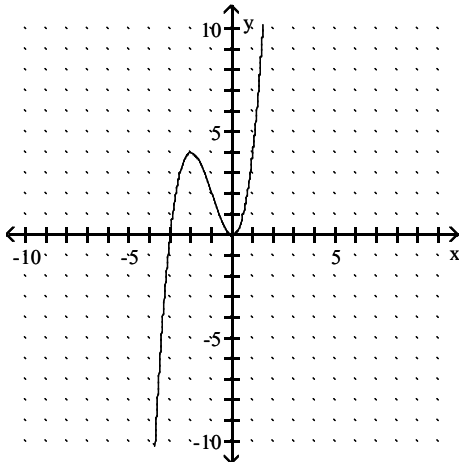

D)

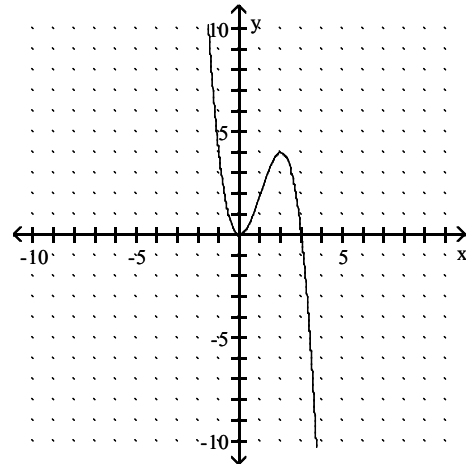

Answer: B

139)  $f(x) = -x^4 - 4x^2$

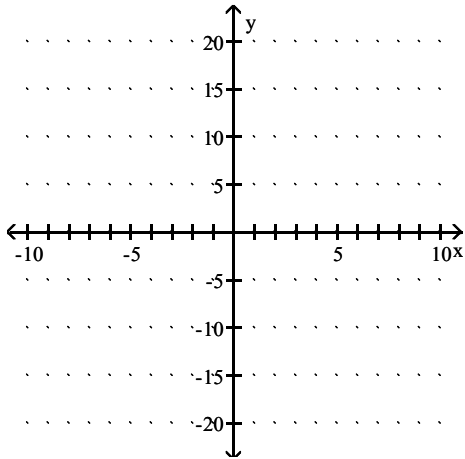

A)

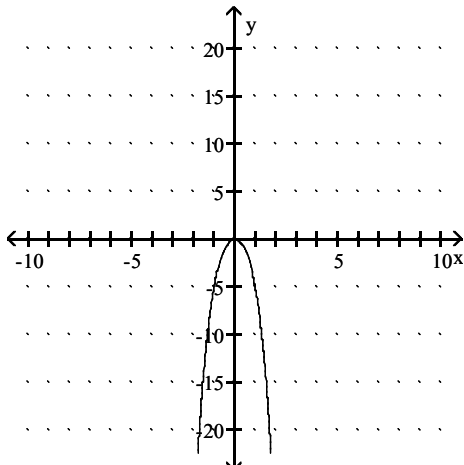

B)

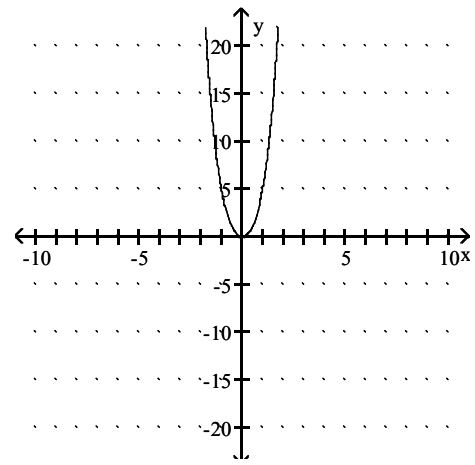

C)

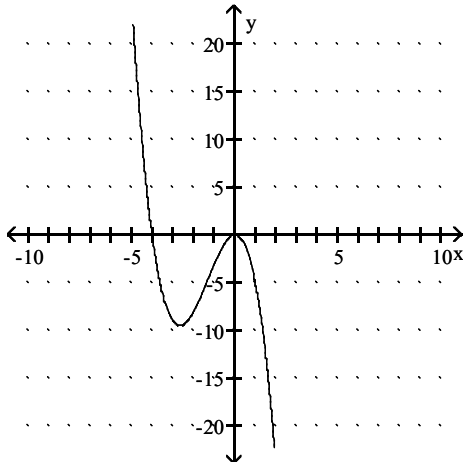

D)

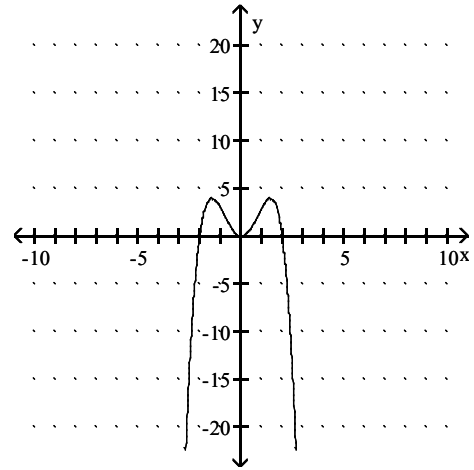

Answer: A

140)  $f(x) = -3x(x - 1)^2$

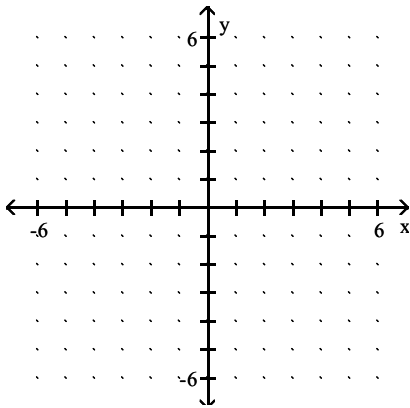

A)

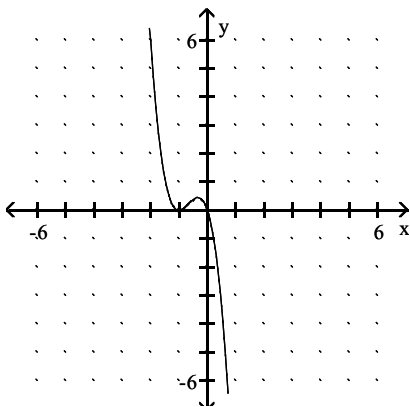

B)

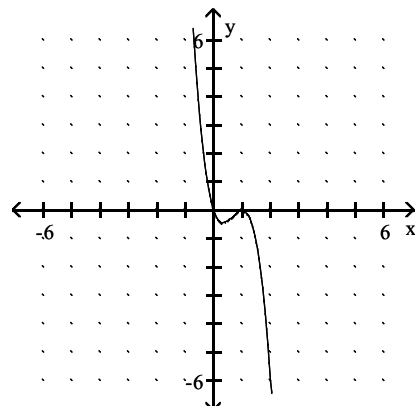

C)

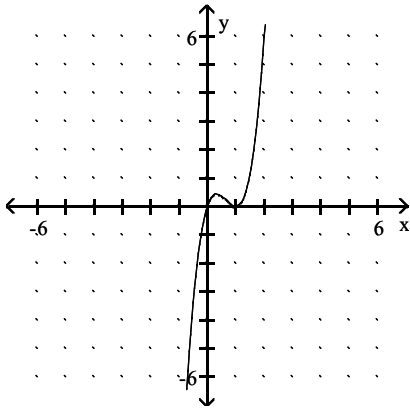

D)

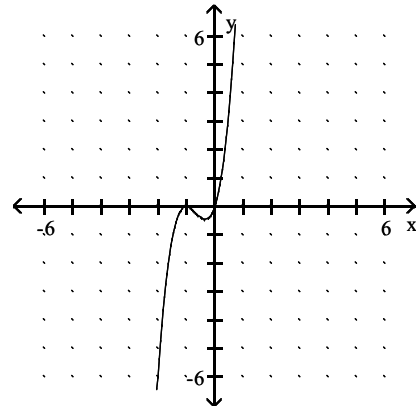

Answer: B

141)  $f(x) = x^2 + 2x - 2$

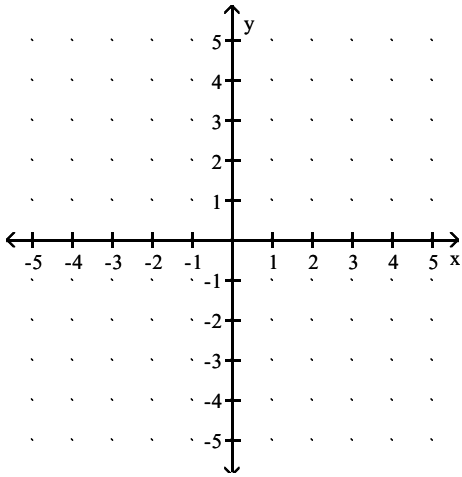

A)

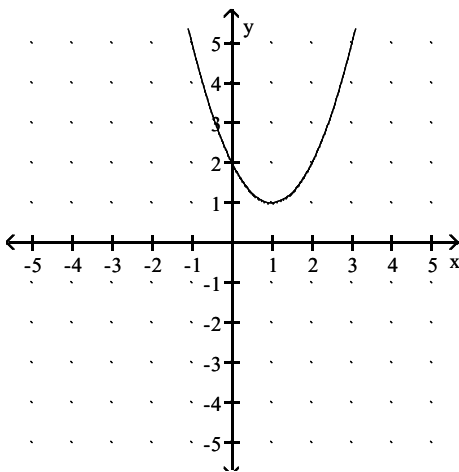

B)

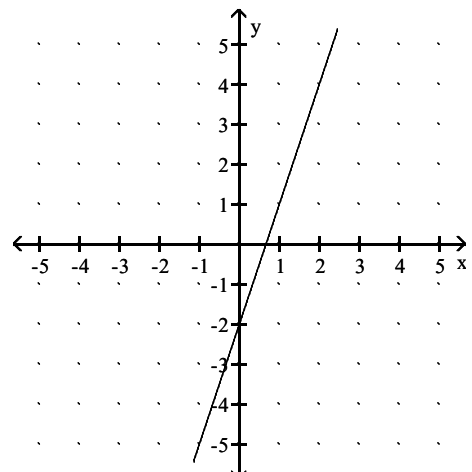



C)

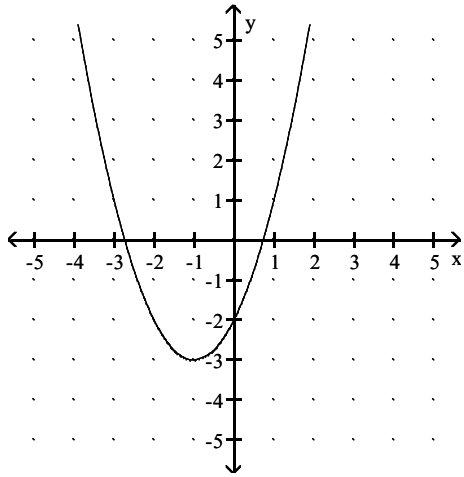

D)

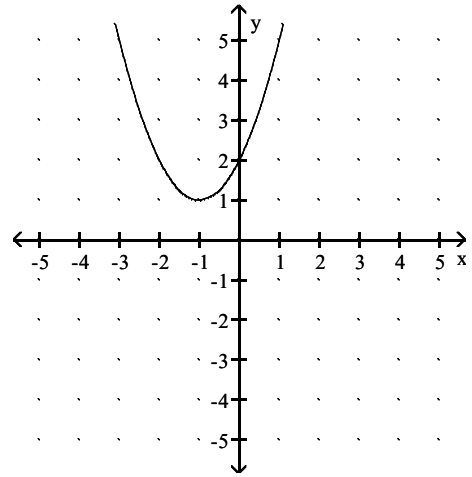

Answer: C

142)  $f(x) = (x + 1)^2(x^2 - 25)$

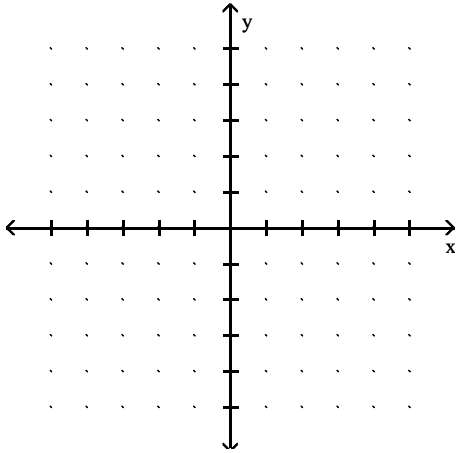

A)

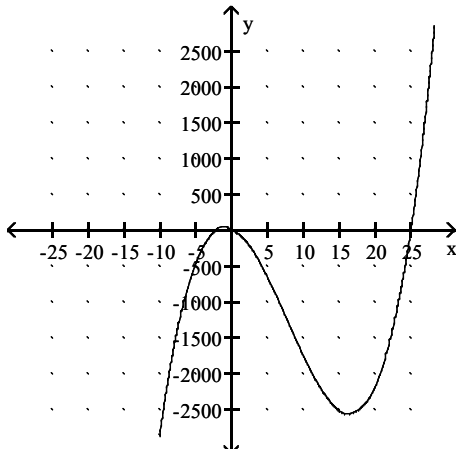

B)

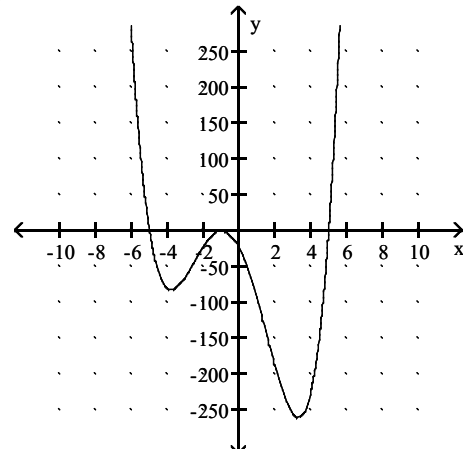

C)

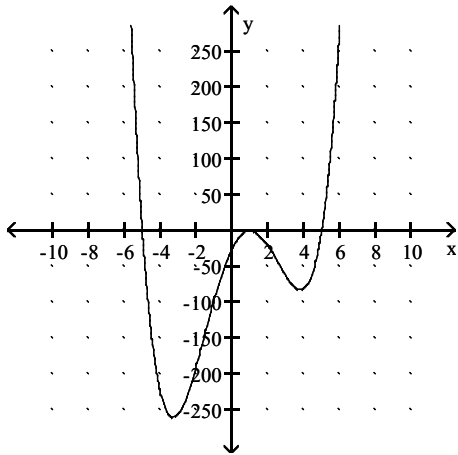

D)

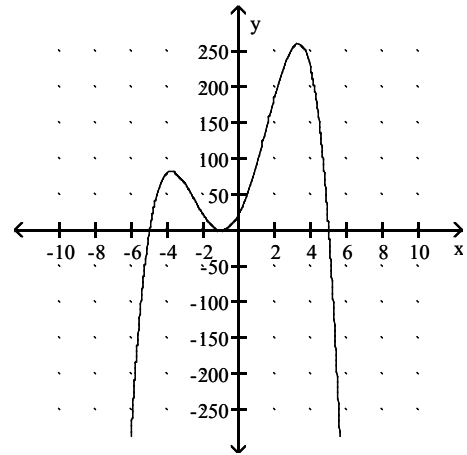

Answer: B

143)  $f(x) = -x^2(x - 1)(x + 1)$

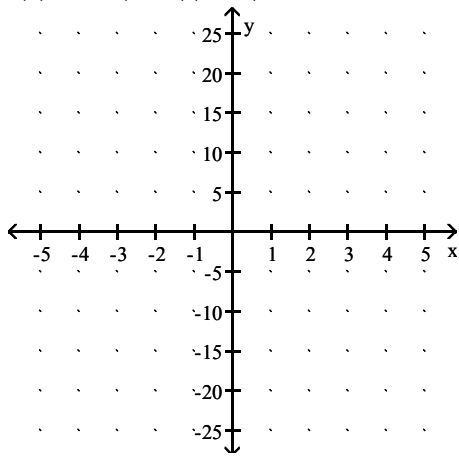

A)

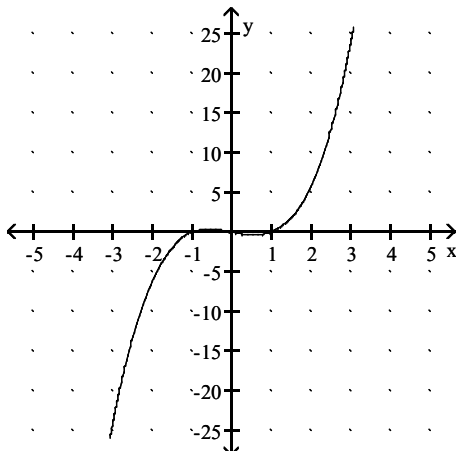

B)

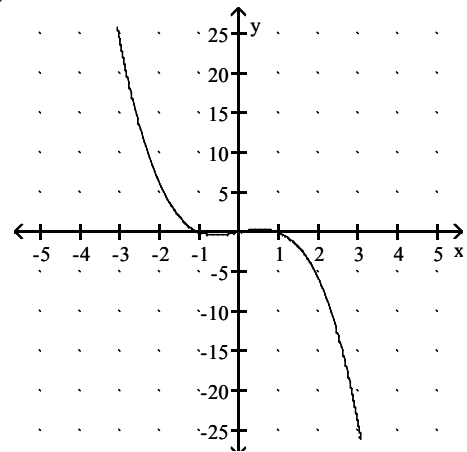

C)

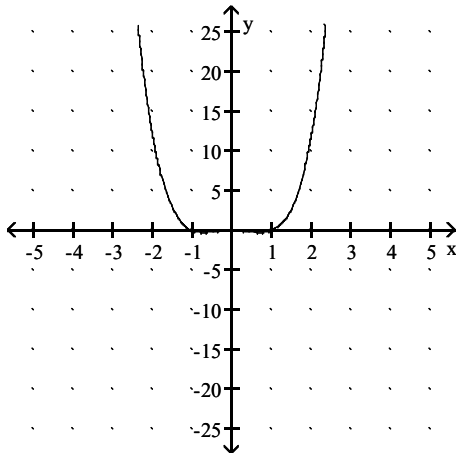

D)

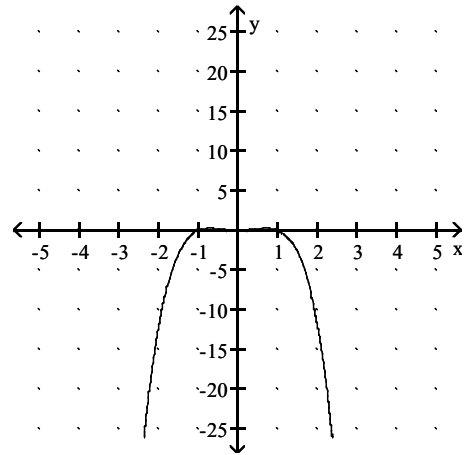

Answer: D

144)  $f(x) = -2x^3(x - 2)^2(x + 2)$

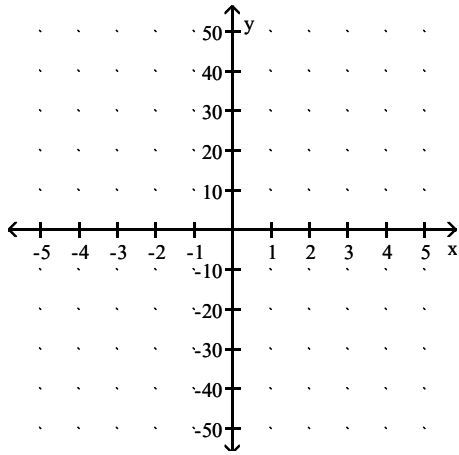

A)

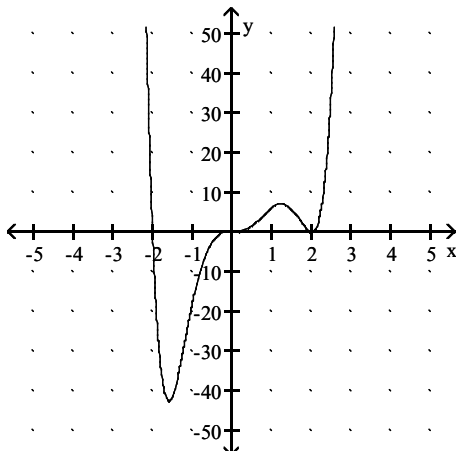

B)

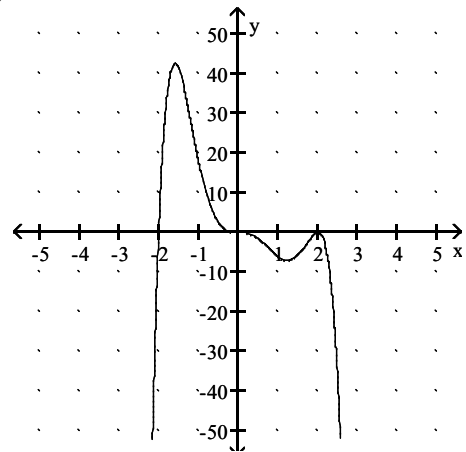

C)

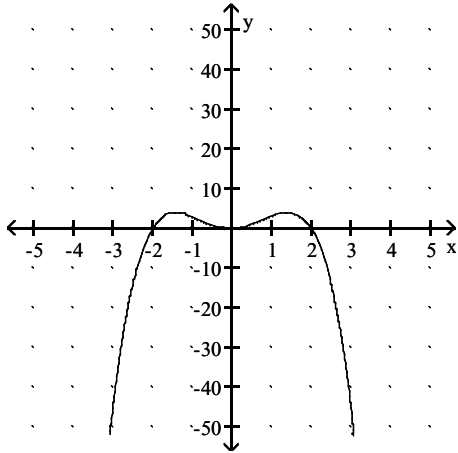

D)

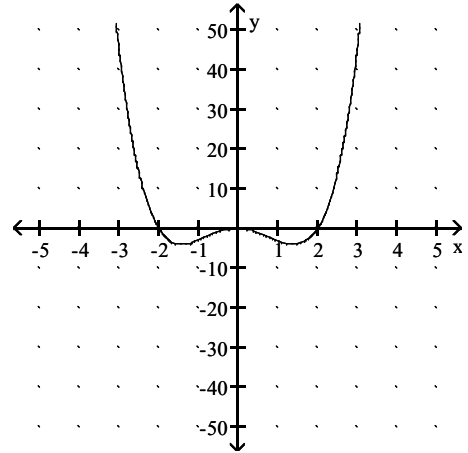

Answer: B

145)  $f(x) = (x + 1)(x + 3)(x + 4)^2$

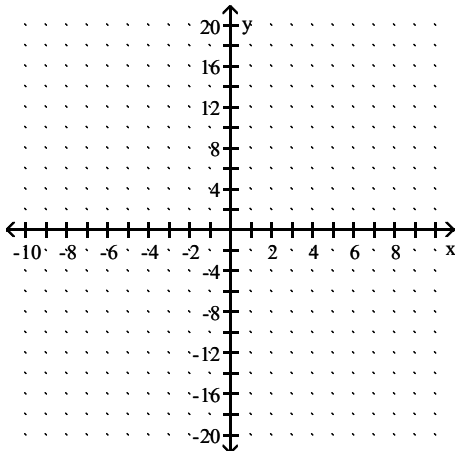

A)

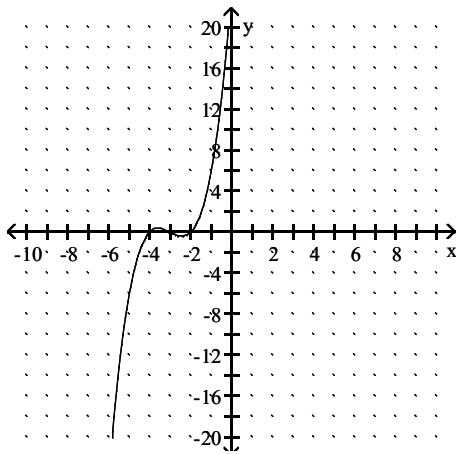

B)

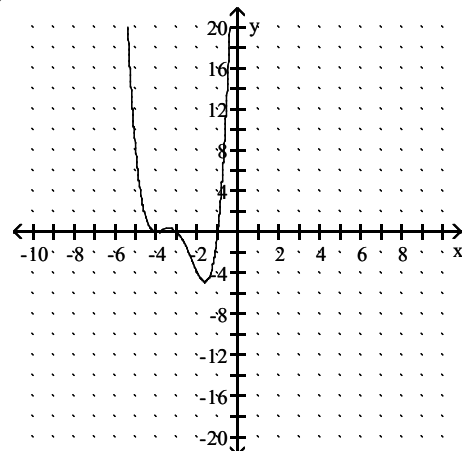

C)

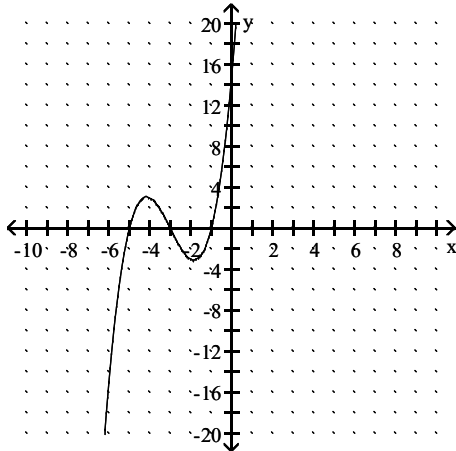

Answer: B

D)

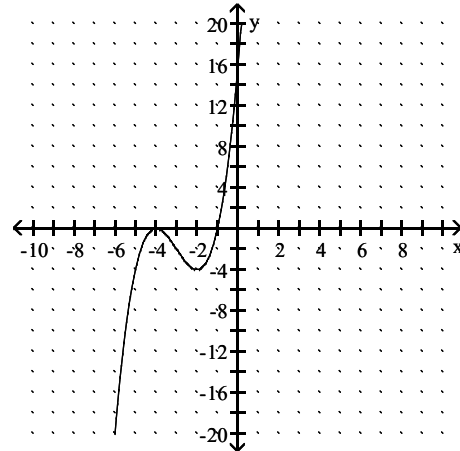
**Solve the problem.**

146) The polynomial  $G(x) = -0.006x^4 + 0.140x^3 - 0.53x^2 + 1.79x$  measures the concentration of a dye in the bloodstream  $x$  seconds after it is injected. Does the concentration increase between 11 and 12 seconds?

A) Yes

B) No

Answer: A

147) A rectangular piece of cardboard measuring 12 inches by 40 inches is to be made into a box with an open top by cutting equal size squares from each corner and folding up the sides. Let  $x$  represent the length of a side of each square. For what value of  $x$  will the volume be a maximum? If necessary, round to 2 decimal places.

A) 2.74 in.

B) 14.59 in.

C) 29.18 in.

D) 16.53 in.

Answer: A

148) A rectangular piece of cardboard measuring 25 inches by 36 inches is to be made into a box with an open top by cutting equal size squares from each corner and folding up the sides. Let  $x$  represent the length of a side of each such square. What is the maximum volume of this box? If necessary, round to 2 decimal places.

A) 505.27 in.<sup>3</sup>B) 29,745.94 in.<sup>3</sup>C) 1951.6 in.<sup>3</sup>D) 465 in.<sup>3</sup>

Answer: C

149)  $P(x) = -x^3 + \frac{27}{2}x^2 - 60x + 100$ ,  $x \geq 5$  is an approximation to the total profit (in thousands of dollars) from the sale

of  $x$  hundred thousand tires. Find the number of hundred thousands of tires that must be sold to maximize profit.

A) 4 hundred thousand

B) 4.5 hundred thousand

C) 5 hundred thousand

D) 5.5 hundred thousand

Answer: C

150)  $S(x) = -x^3 + 6x^2 + 288x + 4000$ ,  $4 \leq x \leq 20$  is an approximation to the number of salmon swimming upstream to spawn, where  $x$  represents the water temperature in degrees Celsius. Find the temperature that produces the maximum number of salmon.

A) 8°C

B) 12°C

C) 20°C

D) 4°C

Answer: B

- 151) Ariel, a marine biologist, models a population  $P$  of crabs,  $t$  days after being left to reproduce, with the function  $P(t) = -0.00009t^3 + 0.024t^2 + 10.5t + 1800$ . Assuming that this model continues to be accurate, when will this population become extinct? (Round to the nearest day.)  
 A) 707 days                      B) 1512 days                      C) 547 days                      D) 911 days

Answer: C

- 152) Suppose that the population of a certain city during a certain time period can be modeled with the function,  $P(x) = -0.1x^5 + 3.7x^4 + 3000$ , where  $x$  is time in years since 1960. By sketching a graph of  $P(x)$ , estimate during what time period the population of the city was increasing.  
 A) Between 1960 and 1975                      B) Between 1965 and 1990  
 C) Between 1990 and 1997                      D) Between 1960 and 1990

Answer: D

- 153) A population of birds in a small county can be modeled by the polynomial  $f(x) = x^3 - 57x^2 + 1162x + 1094$ , where  $x = 1$  corresponds to July 1,  $x = 2$  to July 2, and so on. For what days does  $f$  estimate the population to be 8550?  
 A) July 13th                      B) July 11th                      C) July 12th                      D) July 14th

Answer: C

**Use long division to find the quotient and the remainder**

154)  $\frac{x^2 + 6x - 16}{x + 8}$

- A) quotient:  $x^2 - 2$ ; remainder: 5                      B) quotient:  $x - 2$ ; remainder: 0  
 C) quotient:  $x^2 + 7x - 8$ ; remainder: 0                      D) quotient:  $x + 2$ ; remainder: -2

Answer: B

155)  $\frac{-20x^3 + 4x^2 + 11x + 8}{-5x - 4}$

- A) quotient:  $x^2 + 1$ ; remainder: -4                      B) quotient:  $4x^2 - 4x + 1$ ; remainder: 12  
 C) quotient:  $4x^2 - 4x + 1$ ; remainder: 15                      D) quotient:  $4x^2 - 4x + 1$ ; remainder: 0

Answer: B

156)  $\frac{x^4 + 4x^3 - 4x^2 - 15x + 36}{x^2 + 3x - 3}$

- A) quotient:  $x^2 + 6x + 11$ ; remainder: 0                      B) quotient:  $x^2 + x - 4$ ; remainder: 24  
 C) quotient:  $x^2 + x - 4$ ; remainder: 0                      D) quotient:  $x^2 + 6x + 11$ ; remainder:  $12x - 45$

Answer: B

157)  $\frac{-6t^4 - 4t^3 + 6t^2 + 20t + 10}{2t^2 - 2t - 2}$

- A) quotient:  $-3t^2 - 4t - 5$ ; remainder: 0                      B) quotient:  $-3t^2 - 5t - 5$ ; remainder: 0  
 C) quotient:  $-3t^2 - 5t + 5$ ; remainder: 0                      D) quotient:  $-3t^2 + 5t - 5$ ; remainder: 0

Answer: B

$$158) \frac{x^3 + 1000}{x + 10}$$

A) quotient:  $x^2 - 10x - 100$ ; remainder: 0

C) quotient:  $x^2 + 10x + 100$ ; remainder: 0

Answer: D

B) quotient:  $x^2 + 100$ ; remainder: 0

D) quotient:  $x^2 - 10x + 100$ ; remainder: 0

$$159) \frac{p^2 + 4p - 43}{p + 9}$$

A) quotient:  $p - 5$ ; remainder: 0

C) quotient:  $p - 5$ ; remainder: 2

Answer: C

B) quotient:  $p - 2$ ; remainder: 5

D) quotient:  $p + 5$ ; remainder: 2

$$160) \frac{-6x^3 + 7x^2 + 9x + 4}{3x + 1}$$

A) quotient:  $x^2 + 2$ ; remainder: 3

C) quotient:  $-2x^2 + 3x + 2$ ; remainder: 5

Answer: B

B) quotient:  $-2x^2 + 3x + 2$ ; remainder: 2

D) quotient:  $-2x^2 + 3x + 2$ ; remainder: 0

**Use synthetic division to find the quotient and the remainder when the first polynomial is divided by the second polynomial.**

$$161) x^3 - 5; x - 1$$

A) quotient:  $x^2 + x + 1$ ; remainder: 5

C) quotient:  $x^2 - x - 1$ ; remainder: 0

Answer: B

B) quotient:  $x^2 + x + 1$ ; remainder: -4

D) quotient:  $x^3 - x^2 - x - 1$ ; remainder: 0

$$162) 3x^4 + 2x^2 - 1; x + \frac{1}{4}$$

A) quotient:  $3x^3 - 1$ ; remainder: -4

B) quotient:  $3x^3 - \frac{3}{4}x^2 + \frac{35}{16}x - \frac{35}{64}$ ; remainder:  $-\frac{221}{256}$

C) quotient:  $3x^3 - 1$ ; remainder: 0

D) quotient:  $3x^3 + \frac{3}{4}x^2 - \frac{35}{64}x + \frac{35}{64}$ ; remainder:  $-\frac{221}{256}$

Answer: B

$$163) x^5 - 4x^4 - 9x^3 - 15x^2 - 20x + 14; x - 6$$

A) quotient:  $x^4 + 2x^3 + 3x^2 + 3x + 2$ ; remainder: 4

C) quotient:  $x^4 + 2x^3 + 3x^2 + 3x + 2$ ; remainder: 0

Answer: D

B) quotient:  $x^3 + 2x^2 + 3x + 3$ ; remainder: 2

D) quotient:  $x^4 + 2x^3 + 3x^2 + 3x - 2$ ; remainder: 2

164)  $6x^5 - 5x^4 + x - 4; x + \frac{1}{2}$

A) quotient:  $6x^4 - 2x^3 + x^2 - \frac{1}{2}x + \frac{5}{4}$ ; remainder  $-\frac{37}{8}$

B) quotient:  $6x^4 - 8x^3 + 4x^2 - 2x + 2$ ; remainder  $-5$

C) quotient:  $6x^4 - 8x^3 + 5$ ; remainder  $-\frac{13}{2}$

D) quotient:  $6x^4 - 2x^3 - x^2 + \frac{1}{2}x + \frac{5}{4}$ ; remainder  $-\frac{27}{8}$

Answer: B

165)  $2x^3 + 3x^2 + 4x - 10; x + 1$

A) quotient:  $2x^2 + x + 3$ ; remainder: 13

C) quotient:  $2x^2 + x + 3$ ; remainder:  $-13$

Answer: C

B) quotient:  $2x^2 + 5x + 9$ ; remainder: 1

D) quotient:  $2x^2 + 5x + 9$ ; remainder:  $-1$

166)  $2x^4 - x^3 - 15x^2 + 3x; x + 3$

A) quotient:  $2x^3 - 7x^2 + 6x - 15$ ; remainder:  $-45$

C) quotient:  $2x^3 + 5x^2 + 3$ ; remainder: 9

Answer: D

B) quotient:  $2x^3 - 5x^2 + 3$ ; remainder:  $-9$

D) quotient:  $2x^3 - 7x^2 + 6x - 15$ ; remainder: 45

167)  $2x^5 - x^4 + 3x^2 - x + 5; x - 1$

A) quotient:  $2x^4 + x^3 + x^2 + 4x + 3$ ; remainder: 8

C) quotient:  $2x^4 + x^3 - x^2 + 2x + 1$ ; remainder: 6

Answer: A

B) quotient:  $2x^4 + x^3 + 4x^2 + 3x$ ; remainder: 8

D) quotient:  $2x^4 - 3x^3 + x$ ; remainder: 6

168)  $3x^5 + 4x^4 + 2x^2 - 1; x + 2$

A) quotient:  $3x^4 - 2x^3 + 4x^2 + 6$ ; remainder:  $-13$

B) quotient:  $3x^4 - 2x^3 + 6x^2 - 12$ ; remainder: 23

C) quotient:  $3x^4 + 2x^3 + 4x^2 + 8x$ ; remainder:  $-15$

D) quotient:  $3x^4 - 2x^3 + 4x^2 - 6x + 12$ ; remainder:  $-25$

Answer: D

169)  $2x^5 - x^4 + 3x^2 - x + 5; x - 1$

A) quotient:  $2x^4 + x^3 + 4x^2 + 3x$ ; remainder: 8

C) quotient:  $2x^4 - 3x^3 - x$ ; remainder: 6

Answer: B

B) quotient:  $2x^4 + x^3 + x^2 + 4x + 3$ ; remainder: 8

D) quotient:  $2x^4 + x^3 - x^2 + 2x + 1$ ; remainder: 6

170)  $x^2 + 7x + 7; x + 4$

A) quotient:  $x + 3$ ; remainder: 5

C) quotient:  $x + 3$ ; remainder:  $-5$

Answer: C

B) quotient:  $\frac{x+3}{x+4}$ ; remainder: 0

D) quotient:  $x + 4$ ; remainder: 0



Use synthetic division and the Remainder Theorem to find the function value.

171)  $f(x) = x^3 - 4x^2 + 4x + 1$ ; find  $f(-3)$

A) -76

B) -21

C) -20

D) -74

Answer: D

172)  $f(x) = 2x^3 + 4x^2 + 8x + 1$ ; find  $f(-3)$

A) -67

B) -41

C) 7

D) -93

Answer: B

173)  $f(x) = 4x^3 - 12x^2 - 9x$ ; find  $f\left(-\frac{1}{2}\right)$

A) 4

B) 0

C) 1

D) 2

Answer: C

Use the Factor Theorem to determine whether the linear polynomial is a factor of the second polynomial.

174)  $x - 1$ ;  $x^3 - 4x^2 + 5x - 2$

A) Yes

B) No

Answer: A

175)  $x - 2$ ;  $x^3 + 13x^2 + 34x - 48$

A) Yes

B) No

Answer: B

176)  $x + 6$ ;  $x^3 - 3x^2 - 40x + 84$

A) Yes

B) No

Answer: A

177)  $x + 5$ ;  $x^3 - 12x^2 + 20x + 100$

A) Yes

B) No

Answer: B

178)  $x - 5$ ;  $3x^3 - 14x^2 + 21x - 10$

A) Yes

B) No

Answer: B

179)  $x + 3$ ;  $4x^3 - 38x^2 + 30x + 144$

A) Yes

B) No

Answer: B

180)  $x - 5$ ;  $3x^3 - 19x^2 + 5x + 75$

A) Yes

B) No

Answer: A

181)  $x - 8$ ;  $3x^3 - 23x^2 - 22x + 112$

A) Yes

B) No

Answer: A

182)  $x - 2; x^4 - 10x^3 + 35x^2 - 50x + 24$

A) Yes

B) No

Answer: A

183)  $x + 2; x^4 - x^3 - 3x^2 + 4x + 7$

A) Yes

B) No

Answer: B

**Find the value of k for which the first polynomial is a factor of the second polynomial.**

184)  $x + 3; x^3 + 7x^2 + 11x + k$

A)  $k = -4$

B)  $k = 3$

C)  $k = 4$

D)  $k = -3$

Answer: D

185)  $x - 4; -x^3 + 6x^2 + kx - 12$

A)  $k = -6$

B)  $k = -5$

C)  $k = -7$

D)  $k = 11$

Answer: B

186)  $x - 2; 8x^3 + kx^2 - kx - 8$

A)  $k = -28$

B)  $k = -8$

C)  $k = 8$

D)  $k = 28$

Answer: A

187)  $x - 1; k^2x^3 - 3kx^2 - 6kx + 18$

A)  $k = -6$  or  $3$

B)  $k = 3$  or  $6$

C)  $k = -3$  or  $6$

D)  $k = -6$  or  $-3$

Answer: B

**Find the set of possible rational zeros given the function.**

188)  $f(x) = x^3 - 5x^2 + 10x - 24$

A)  $\left\{ \pm 1, \pm \frac{1}{2}, \pm 2, \pm 3, \pm 4, \pm 6, \pm 8, \pm 12, \pm 24 \right\}$

B)  $\{ \pm 1, \pm 2, \pm 3, \pm 4, \pm 24 \}$

C)  $\{ \pm 1, \pm 2, \pm 3, \pm 4, \pm 6, \pm 8, \pm 12, \pm 24 \}$

D)  $\{ \pm 1, \pm 2, \pm 3, \pm 4, \pm 6, \pm 12, \pm 24 \}$

Answer: C

189)  $f(x) = 2x^3 + 8x^2 + 13x - 8$

A)  $\{ \pm 1, \pm 2, \pm 4, \pm 8 \}$

B)  $\left\{ \pm 1, \pm \frac{1}{2}, \pm 2, \pm 4, \pm 8 \right\}$

C)  $\left\{ \pm 1, \pm \frac{1}{2}, \pm \frac{1}{4}, \pm \frac{1}{8}, \pm 2 \right\}$

D)  $\{ \pm 1, \pm 2, \pm 4 \}$

Answer: B

190)  $f(x) = 3x^3 + 37x^2 + 37x + 27$

A)  $\{ \pm 1, \pm 3, \pm 9, \pm 27 \}$

B)  $\{ \pm 1, \pm 3, \pm 6, \pm 9, \pm 27 \}$

C)  $\left\{ \pm 1, \pm \frac{1}{3}, \pm 3, \pm 9, \pm 27 \right\}$

D)  $\left\{ \pm 1, \pm \frac{1}{3}, \pm \frac{1}{9}, \pm \frac{1}{27}, \pm 3 \right\}$

Answer: C

191)  $f(x) = 2x^3 - 5x^2 + 7x - 17$

- A)  $\left\{ \pm 1, \pm 2, \pm 17, \pm \frac{17}{2} \right\}$   
 C)  $\left\{ \pm 1, \pm 17, \pm \frac{1}{2}, \pm \frac{17}{2} \right\}$

B)  $\{ \pm 1, \pm 2, \pm 17 \}$

D)  $\left\{ \pm 1, \pm \frac{1}{17}, \pm 2, \pm \frac{2}{17} \right\}$

Answer: C

192)  $f(x) = 14x^7 + 56x^3 + 2x - 7$

- A)  $\left\{ \pm 1, \pm \frac{1}{2}, \pm 7, \pm \frac{2}{7}, \pm \frac{1}{14} \right\}$   
 C)  $\left\{ \pm 1, \pm \frac{1}{7}, \pm 2, \pm \frac{2}{7}, \pm 7, \pm 14 \right\}$

B)  $\left\{ \pm 1, \pm \frac{1}{2}, \pm 7, \pm \frac{7}{2}, \pm \frac{1}{7}, \pm \frac{1}{14} \right\}$

D)  $\left\{ \pm 1, \pm 7, \pm \frac{1}{2} \right\}$

Answer: B

**Find all rational zeros.**

193)  $f(x) = x^3 + 5x^2 - 52x - 224$

A)  $\{-5, -8, 14\}$

B)  $\{4, 8, -7\}$

C)  $\{-4, -8, 7\}$

D)  $\{5, 8, -14\}$

Answer: C

194)  $f(x) = x^3 - 6x^2 - 4x + 24$

A)  $\{2, 6, -2\}$

B)  $\{3, 7, -2\}$

C)  $\{-2, -6, 2\}$

D)  $\{-3, -7, 2\}$

Answer: A

195)  $f(x) = 4x^3 - 20x^2 - x + 5$

A)  $\{1, -1, 5\}$

B)  $\left\{ \frac{1}{2}, -\frac{1}{2}, -5 \right\}$

C)  $\{2, -2, 5\}$

D)  $\left\{ \frac{1}{2}, -\frac{1}{2}, 5 \right\}$

Answer: D

196)  $f(x) = 12x^3 + 49x^2 + 3x - 4$

A)  $\{-3, -4, -4\}$

B)  $\{-3, 4, -4\}$

C)  $\left\{ -\frac{1}{3}, \frac{1}{4}, -4 \right\}$

D)  $\left\{ -\frac{1}{12}, 1, -4 \right\}$

Answer: C

197)  $f(x) = 10x^3 + 13x^2 + 2x - 1$

A)  $\left\{ -\frac{1}{2}, \frac{1}{5}, -1 \right\}$

B)  $\{-2, 5, -1\}$

C)  $\left\{ -\frac{1}{10}, 1, -1 \right\}$

D)  $\{-2, -5, -1\}$

Answer: A

198)  $f(x) = 8x^3 + 2x^2 - 5x + 1$

A)  $\left\{ \frac{1}{8}, 1, -1 \right\}$

B)  $\left\{ \frac{1}{8}, 4, -1 \right\}$

C)  $\left\{ \frac{1}{2}, \frac{1}{4}, -1 \right\}$

D)  $\{2, 4, -1\}$

Answer: C

199)  $f(x) = x^4 - 6x^3 + 2x^2 + 18x - 15$

A)  $\{5, -1\}$

B)  $\{5, 1\}$

C)  $\{-5, 1\}$

D) No rational zeros

Answer: B

200)  $f(x) = x^4 + 3x^3 + 3x^2 - 6x - 27$

A)  $\{3, -1\}$

B)  $\{-3, 2\}$

C)  $\{-3, -3\}$

D) No rational zeros

Answer: D

**Find all rational zeros of f. Then (if necessary) use the depressed equation to find all roots of the equation  $f(x) = 0$ .**

201)  $f(x) = x^3 - 9x^2 + 12x + 14$

A)  $\{-7, 1 - \sqrt{3}, 1 + \sqrt{3}\}$

C)  $\{7, -1 - \sqrt{3}, -1 + \sqrt{3}\}$

B)  $\{-7, -1 - \sqrt{3}, -1 + \sqrt{3}\}$

D)  $\{7, 1 - \sqrt{3}, 1 + \sqrt{3}\}$

Answer: D

202)  $f(x) = x^3 + 7x^2 + 8x + 2$

A)  $\{-1, -3 - \sqrt{7}, -3 + \sqrt{7}\}$

C)  $\{1, -1, -2\}$

B)  $\{-1, -6 + \sqrt{2}, -6 - \sqrt{2}\}$

D)  $\{1, -6 + \sqrt{7}, -6 - \sqrt{7}\}$

Answer: A

203)  $f(x) = 3x^3 - x^2 - 9x + 3$

A)  $\{-3, \sqrt{3}, -\sqrt{3}\}$

B)  $\left\{\frac{1}{3}, \sqrt{3}, -\sqrt{3}\right\}$

C)  $\left\{-\frac{1}{3}, \sqrt{3}, -\sqrt{3}\right\}$

D)  $\{3, \sqrt{3}, -\sqrt{3}\}$

Answer: B

204)  $f(x) = 3x^3 - 25x^2 + 35x - 9$

A)  $\left\{\frac{1}{3}, -4 - \sqrt{7}, -4 + \sqrt{7}\right\}$

C)  $\left\{\frac{1}{3}, 4 - \sqrt{7}, 4 + \sqrt{7}\right\}$

B)  $\left\{-\frac{1}{3}, -4 - \sqrt{7}, -4 + \sqrt{7}\right\}$

D)  $\left\{-\frac{1}{3}, 4 - \sqrt{7}, 4 + \sqrt{7}\right\}$

Answer: C

205)  $f(x) = x^4 - 4x^3 - 8x^2 + 36x - 9$

A)  $\{0, 3, 2 + \sqrt{3}, 2 - \sqrt{3}\}$

C)  $\{0, -3, 2 + \sqrt{3}, 2 - \sqrt{3}\}$

B)  $\{3, -3, 2 + \sqrt{3}, 2 - \sqrt{3}\}$

D)  $\{3, -3, -2 + \sqrt{3}, -2 - \sqrt{3}\}$

Answer: B

206)  $f(x) = x^4 + 3x^3 - 16x^2 - 42x - 24$

A)  $\{-1, 4, -3 + \sqrt{3}, -3 - \sqrt{3}\}$

C)  $\{-1, -4, -3 + \sqrt{5}, -3 - \sqrt{5}\}$

B)  $\{-1, 5, -3 + \sqrt{5}, -3 - \sqrt{5}\}$

D)  $\{1, -4, -3 + \sqrt{3}, -3 - \sqrt{3}\}$

Answer: A

207)  $f(x) = x^4 - 3x^3 - 17x^2 + 21x + 70$

A)  $\{2, 5, -\sqrt{7}, \sqrt{7}\}$

B)  $\{-5, -2, -\sqrt{7}, \sqrt{7}\}$

C)  $\{-2, 5, -\sqrt{7}, \sqrt{7}\}$

D)  $\{-5, 2, -\sqrt{7}, \sqrt{7}\}$

Answer: C

208)  $f(x) = 2x^4 + -12x^3 - 12x^2 - 35x - 14$

A)  $\{-\frac{1}{2}, 2, -\sqrt{7}, \sqrt{7}\}$

B)  $\{\frac{1}{2}, 2, -\sqrt{7}, \sqrt{7}\}$

C)  $\{-2, -\frac{1}{2}, -\sqrt{7}, \sqrt{7}\}$

D)  $\{-2, \frac{1}{2}, -\sqrt{7}, \sqrt{7}\}$

Answer: C

209)  $f(x) = x^5 + 4x^4 - 6x^3 - 24x^2 + 5x + 20$

A)  $\{-1, 1, 4, -\sqrt{5}, \sqrt{5}\}$

C)  $\{-4, -1, 1, -\sqrt{5}, \sqrt{5}\}$

B)  $\{-1, 0, 1, -\sqrt{5}, \sqrt{5}\}$

D)  $\{-4, -1, 0, 1, \sqrt{5}\}$

Answer: C

210)  $f(x) = x^5 - 10x^4 + 26x^3 + 10x^2 - 87x + 60$

A)  $\{-5, -4, -1, -\sqrt{3}, \sqrt{3}\}$

C)  $\{1, 4, 5, -\sqrt{3}, \sqrt{3}\}$

B)  $\{0, 1, 4, 5, \sqrt{3}\}$

D)  $\{-5, -4, 1, -\sqrt{3}, \sqrt{3}\}$

Answer: C

**Solve the problem.**

211) The Cool Company determines that the supply function for its basic air conditioning unit is  $S(p) = 20 + 0.004p^3$  and that its demand function is  $D(p) = 100 - 0.08p^2$ , where  $p$  is the price. Determine the price for which the supply equals the demand.

A) \$22.86

B) \$22.36

C) \$21.36

D) \$21.86

Answer: D

212) Ariel, a marine biologist, models a population  $P$  of crabs,  $t$  days after being left to reproduce, with the function  $P(t) = -0.00009t^3 + 0.024t^2 + 10.5t + 1800$ . Assuming that this model continues to be accurate, when will this population become extinct? (Round to the nearest day.)

A) 707 days

B) 911 days

C) 547 days

D) 1512 days

Answer: C

213) A population of birds in a small county can be modeled by the polynomial  $f(x) = x^3 - 57x^2 + 1162x + 1094$ , where  $x = 1$  corresponds to July 1,  $x = 2$  to July 2, and so on. For what days does  $f$  estimate the population to be 8550?

A) July 14th

B) July 12th

C) July 11th

D) July 13th

Answer: B

214) The instantaneous growth rate of a population is the rate at which it is growing at every instant in time. The instantaneous growth rate  $r$  of a colony of bacteria  $t$  hours after the start of an experiment is given by the function  $r = 0.01t^3 + 0.01t^2 - 0.1t + 0.08$  for  $0 \leq t \leq 7$ . Find the times for which the instantaneous growth rate is zero.

A) 1 sec, 2 sec, and 4 sec

C) 2 sec and 4 sec

B) 1 sec and 2 sec

D) 1 sec

Answer: B

- 215) A box with an open top is formed by cutting squares out of the corners of a rectangular piece of cardboard and then folding up the sides. If  $x$  represents the length of the side of the square cut from each corner, and if the original piece of cardboard is 14 inches by 8 inches, what size square must be cut if the volume of the box is to be 72 cubic inches?

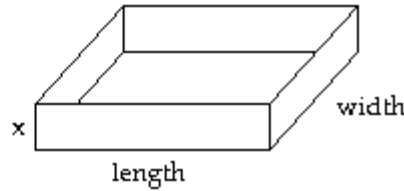
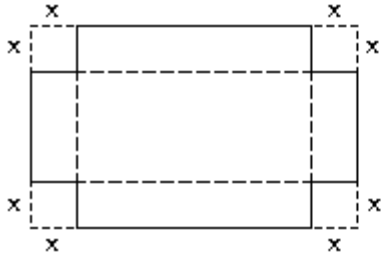

- A) 6 in. by 6 in. square  
C) 1 in. by 1 in. square

- B) 4 in. by 4 in. square  
D) 12 in. by 12 in. square

Answer: C

- 216) A box with an open top is formed by cutting squares out of the corners of a rectangular piece of cardboard and then folding up the sides. If  $x$  represents the length of the side of the square cut from each corner, and if the original piece of cardboard is 14 inches by 12 inches, what size square must be cut if the volume of the box is to be 144 cubic inches?

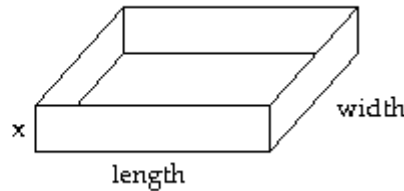
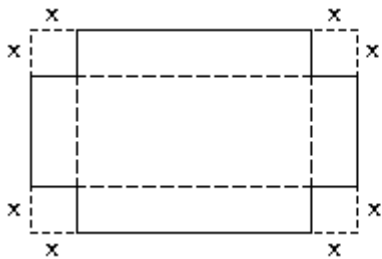

- A)  $x = 6$  in.

- B)  $x = 3$  in.

- C)  $x = 8$  in.

- D)  $x = 4$  in.

Answer: B

- 217) The revenue from the sale of a product is given by  $R = 1408x - 17x^2 - x^3$ . If the sale of 11 units gives a total revenue of \$12,100, find another number of units that will give \$12,100 in revenue.

- A) 50 units

- B) 12 units

- C) 27 units

- D) 22 units

Answer: D

- 218) The profit function for a product is given by  $P(x) = -0.1x^3 + 16.5x^2 - 530x - 12,000$  dollars, where  $x$  is the number of units produced and sold. Determine the levels of production and sale that give break-even.

- A) 100 units

- B) 90 or 120 units

- C) 120 units

- D) 80 or 100 units

Answer: D

- 219) The concentration, in parts per million, of a particular drug in a patient's blood  $x$  hours after the drug is administered is given by the function,  $f(x) = -x^4 + 9x^3 - 29x^2 + 45x$ . How many hours after the drug is administered will it be eliminated from the bloodstream.

- A) 4 hours

- B) 14 hours

- C) 9 hours

- D) 5 hours

Answer: D

220) The length of a rectangle is  $x^2 - 3x + 2$  and its width is  $x - 3$ . Find its dimensions assuming that its area is 210 square units.

A) Length: 5; width: 5

B) Length: 210; width: 8

C) Length: 69; width: 11

D) Length: 210; width: 5

Answer: D

221) The accompanying graph shows the average number of degrees above/below normal in December from 2000 - 2009 where  $x = 0$  represents 2000.

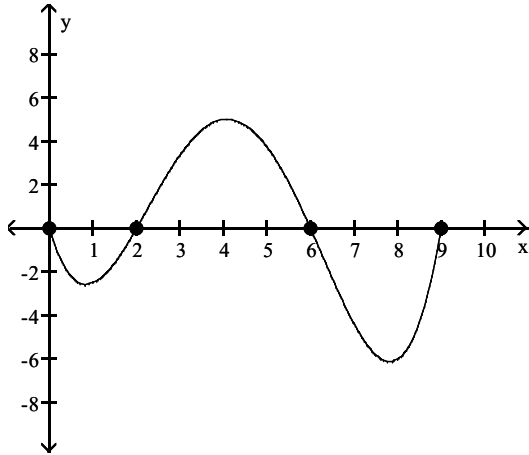

Construct a polynomial of minimum degree that models the graph.

A)  $y = \frac{1}{16}(x - 2)(x - 6)(x - 9)$

B)  $y = -\frac{1}{16}x(x - 2)(x - 6)(x - 9)$

C)  $y = \frac{1}{16}x(x - 2)(x - 6)(x - 9)$

D)  $y = \frac{1}{16}x(x + 2)(x + 6)(x + 9)$

Answer: C

222) The accompanying graph shows the average number of degrees above/below normal in December from 2000–2009 where  $x = 0$  represents 2000.

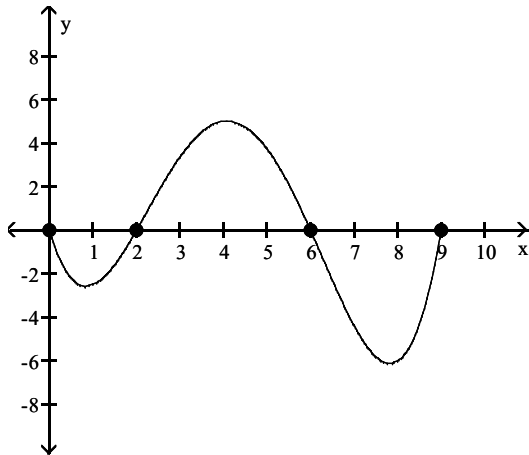

Estimate the number of degrees above zero in 2004. Round to the nearest tenth.

- A) 32 degrees above normal
- B) 5 degrees above normal
- C) 141 degrees above normal
- D) 1.3 degrees above normal

Answer: B

223) The accompanying graph shows the average number of degrees above/below normal in December from 2000 – 2009 where  $x = 0$  represents 2000.

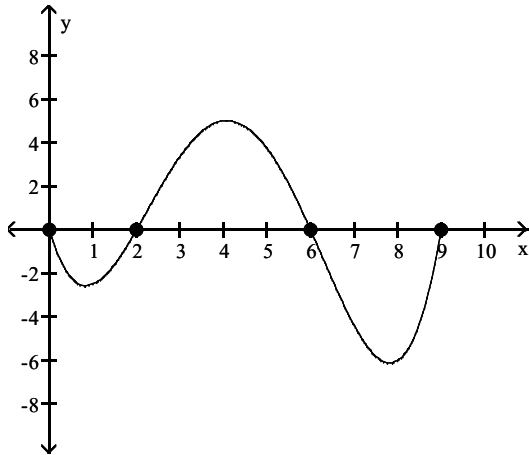

Estimate the number of degrees below zero in 2007. Round to the nearest tenth.

- A) 42.9 degrees below normal
- B) 0.6 degrees below normal
- C) 4.4 degrees below normal
- D) -819 degrees below normal

Answer: C

**Find the domain of the rational function.**

224)  $g(x) = \frac{x - 3}{x + 2}$

- A)  $(-\infty, \infty)$
- B)  $(-\infty, 0) \cup (0, \infty)$
- C)  $(-\infty, -2) \cup (-2, \infty)$
- D)  $(-\infty, 3) \cup (3, \infty)$

Answer: C



$$225) f(x) = \frac{x-1}{x^2+4}$$

A)  $(-\infty, \infty)$

C)  $(-\infty, -1) \cup (-1, 1) \cup (1, \infty)$

B)  $(-\infty, -4) \cup (-4, \infty)$

D)  $(-\infty, 4) \cup (4, \infty)$

Answer: A

Use the graph of the rational function  $f(x)$  to complete the statement.

226) As  $x \rightarrow -2^-$ ,  $f(x) \rightarrow$  \_\_\_\_ .

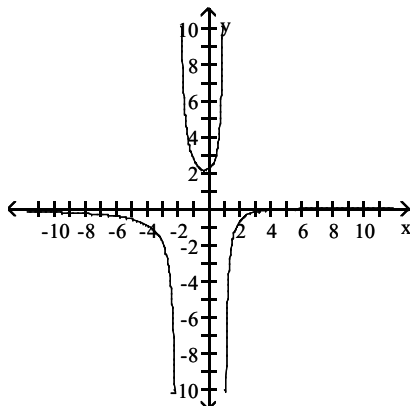

A) 2

B)  $-\infty$

C) 0

D)  $+\infty$

Answer: B

227) As  $x \rightarrow -2^+$ ,  $f(x) \rightarrow$  \_\_\_\_ .

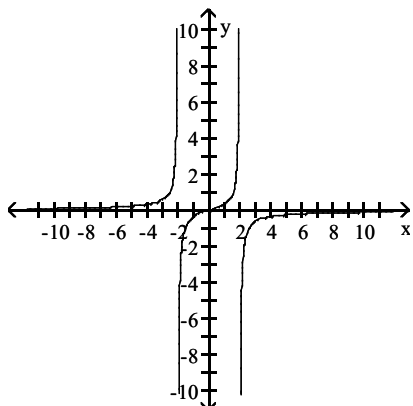

A)  $-\infty$

B) 2

C) 0

D)  $+\infty$

Answer: A

228) As  $x \rightarrow -\infty$ ,  $f(x) \rightarrow$  \_\_\_\_.

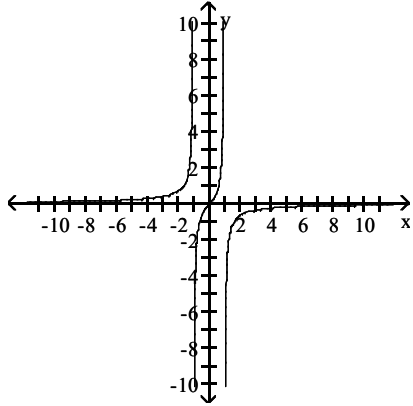

A) -1

B)  $+\infty$

C)  $-\infty$

D) 0

Answer: D

229) As  $x \rightarrow 3^-$ ,  $f(x) \rightarrow$  \_\_\_\_.

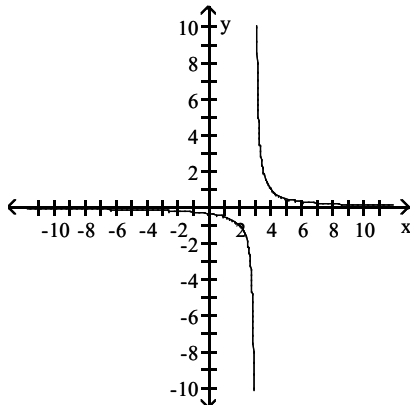

A)  $-\infty$

B)  $+\infty$

C) -3

D) 0

Answer: A

230) As  $x \rightarrow -2^-$ ,  $f(x) \rightarrow$  \_\_\_\_.

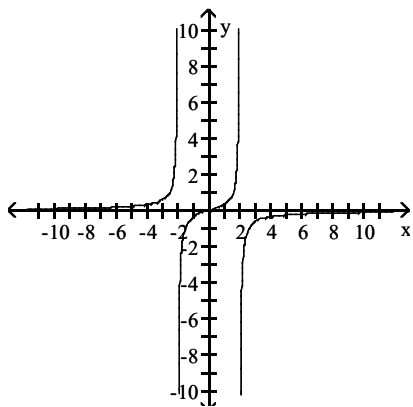

A)  $+\infty$

B) 0

C) 2

D)  $-\infty$

Answer: A

231) As  $x \rightarrow -2^+$ ,  $f(x) \rightarrow$  \_\_\_\_.

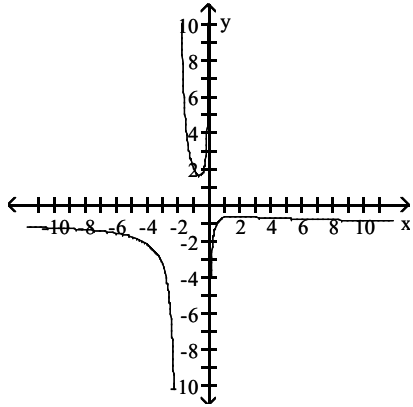

A)  $-\infty$

B) -2

C) 1

D)  $+\infty$

Answer: D

232) As  $x \rightarrow 2^-$ ,  $f(x) \rightarrow$  \_\_\_\_.

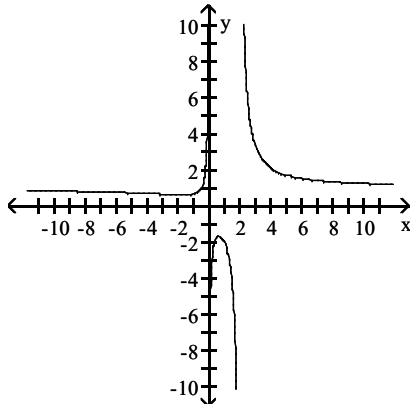

A) -2

B) 1

C)  $+\infty$

D)  $-\infty$

Answer: D

233) As  $x \rightarrow +\infty$ ,  $f(x) \rightarrow$  \_\_\_\_.

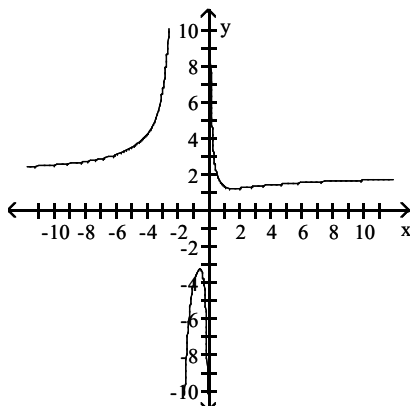

A)  $+\infty$

B) 2

C)  $-\infty$

D) -2

Answer: B

234) As  $x \rightarrow 0^+$ ,  $f(x) \rightarrow$  \_\_\_\_.

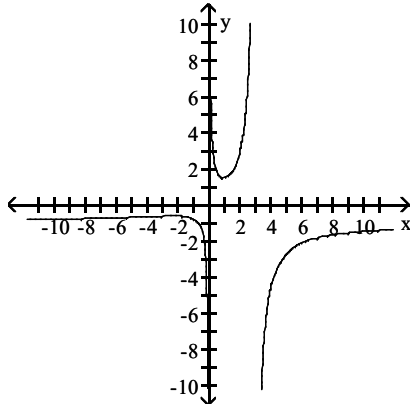

- A)  $-\infty$                       B)  $+\infty$                       C) -1                      D) 1

Answer: B

235) The equations of the vertical asymptotes are \_\_\_\_\_ and \_\_\_\_\_.

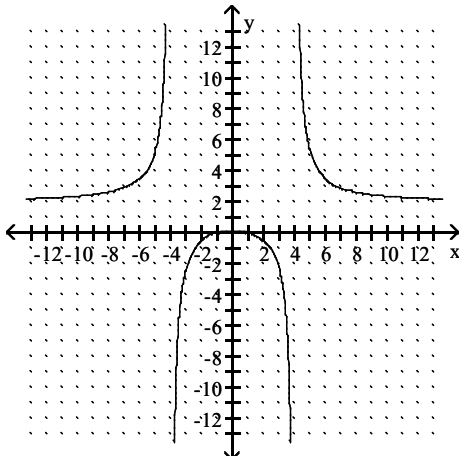

- A)  $x = 1, x = -1$                       B)  $x = 4, x = -4$                       C)  $x = 2, x = 4$                       D)  $x = 1, x = 4$

Answer: B

236) The equation of the horizontal asymptote is \_\_\_\_\_.

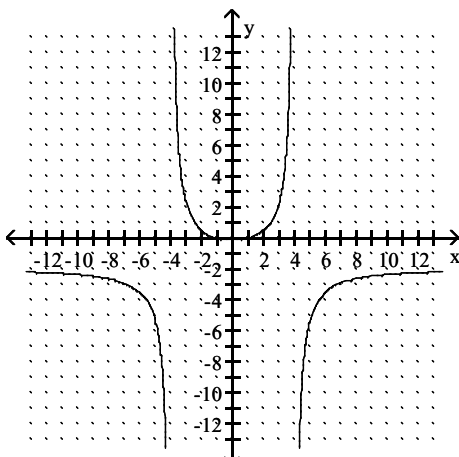

- A)  $y = 4$                       B)  $y = 1$                       C)  $y = 2$                       D)  $y = -2$

Answer: D

Find the vertical asymptote(s), if any, of the graph of the rational function.

$$237) g(x) = \frac{x+3}{x-6}$$

A)  $y = 6$

B)  $x = -3$

C)  $x = 6$

D)  $x = -6$

Answer: C

$$238) h(x) = \frac{x^2 - 100}{(x-1)(x+2)}$$

A)  $x = -1$

B)  $x = 10, x = -10$

C)  $y = 1, y = -2$

D)  $x = 1, x = -2$

Answer: D

$$239) f(x) = \frac{x^2 + 5x}{x^2 - 3x - 40}$$

A)  $x = 8, x = -5$

C)  $x = -8, x = 5$

B) no vertical asymptote

D)  $x = 8$

Answer: D

$$240) f(x) = \frac{x-1}{x^2+8}$$

A)  $x = -8$

C) no vertical asymptote

B)  $x = 1, x = -1$

D)  $x = 8$

Answer: C

Find the horizontal asymptote(s), if any, of the graph of the rational function.

$$241) g(x) = \frac{x^2 + 3x - 2}{x - 2}$$

A)  $y = -3$

C)  $y = 5$

B)  $y = 2$

D) no horizontal asymptote

Answer: D

$$242) g(x) = \frac{x+4}{x^2-9}$$

A)  $y = 0$

C)  $y = -4$

B)  $y = 9$

D) no horizontal asymptote

Answer: A

$$243) f(x) = \frac{-3x-2}{4x+1}$$

A)  $y = -3$

C)  $y = -\frac{3}{4}$

B)  $y = -2$

D) no horizontal asymptote

Answer: C

$$244) g(x) = \frac{2x^2 - 5x - 5}{8x^2 - 4x + 2}$$

A)  $y = \frac{5}{4}$

C)  $y = 0$

Answer: B

B)  $y = \frac{1}{4}$

D) no horizontal asymptote

$$245) g(x) = \frac{x + 7}{x^2 - 8}$$

A)  $y = -7$

C)  $y = 0$

Answer: C

B)  $y = 8$

D) no horizontal asymptote

$$246) h(x) = \frac{x^2 - 25}{x + 5}$$

A)  $y = -5$

C)  $y = 1$

Answer: D

B)  $y = 5$

D) no horizontal asymptote

$$247) f(x) = \frac{5x^2 + 8x - 2}{4x^3 - 4x + 7}$$

A)  $y = \frac{5}{4}$

C)  $y = 0$

Answer: C

B)  $y = 5$

D) no horizontal asymptote

Match the rational function with the appropriate graph.

$$248) f(x) = \frac{18}{x^2 - 9}$$

A)

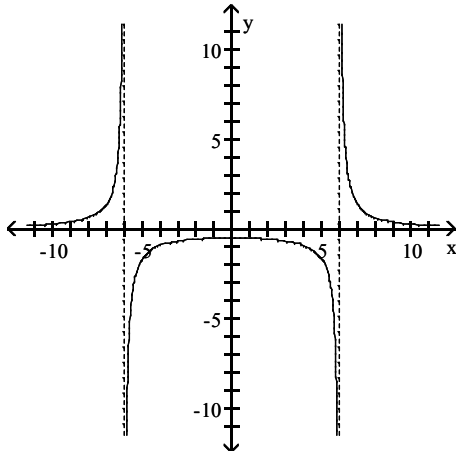

B)

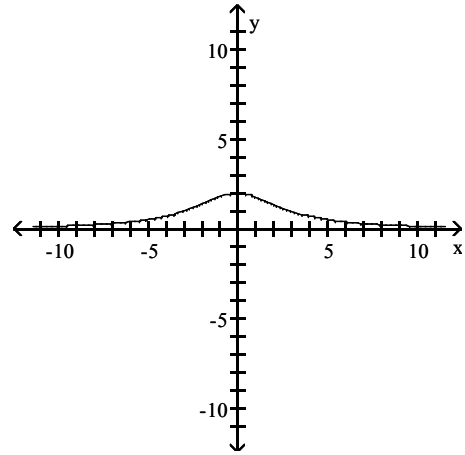

C)

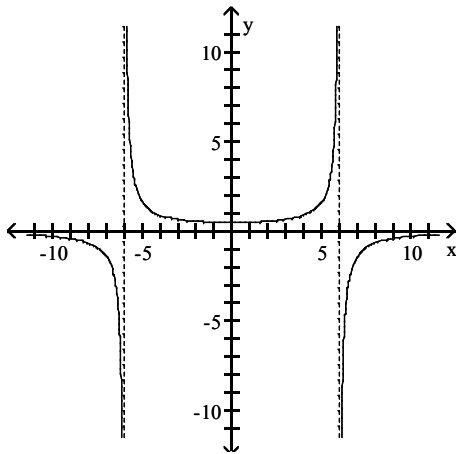

D)

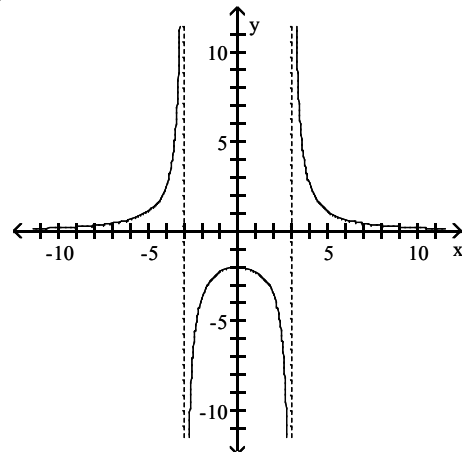

Answer: D

249)  $f(x) = \frac{18}{x^2 + 9}$

A)

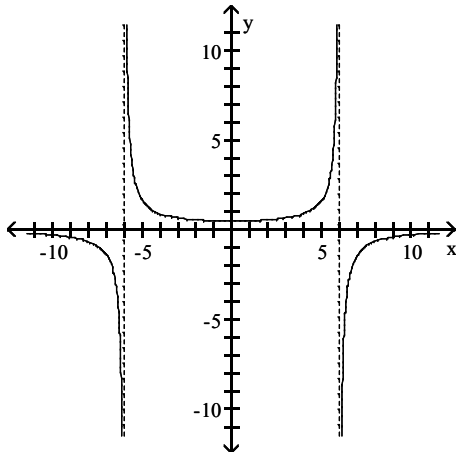

B)

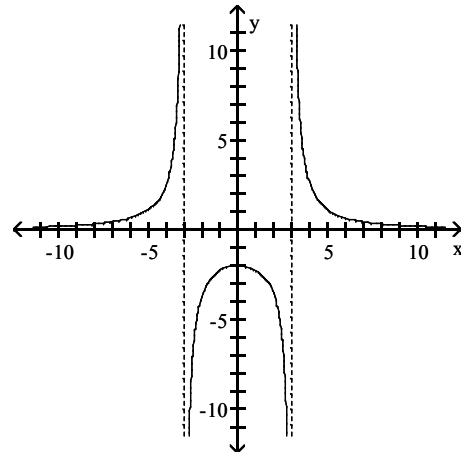

C)

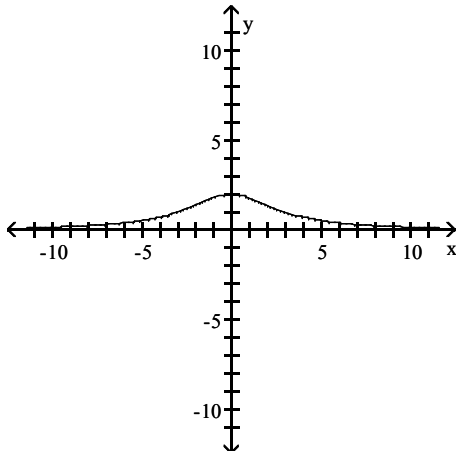

D)

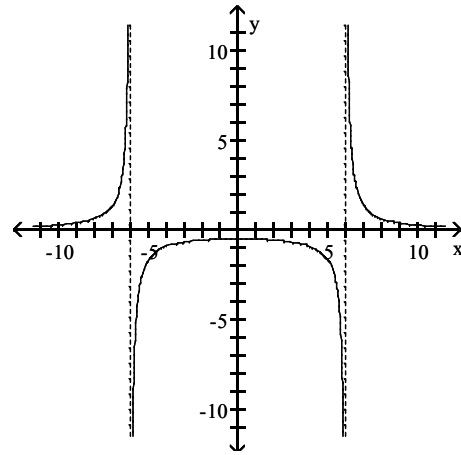

Answer: C



250)  $f(x) = \frac{6x}{x^2 - 1}$

A)

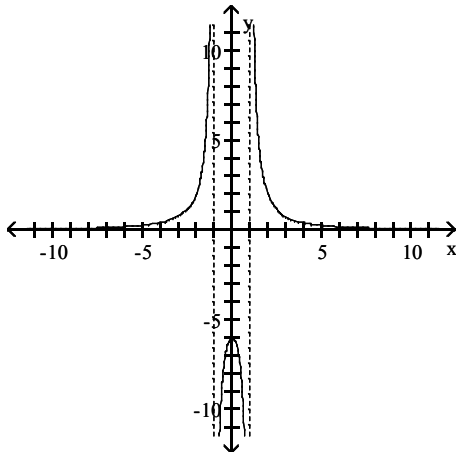

B)

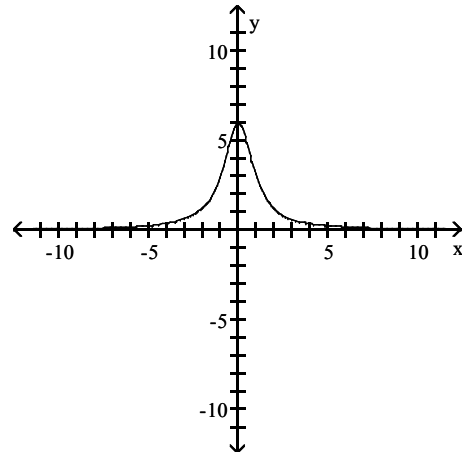

C)

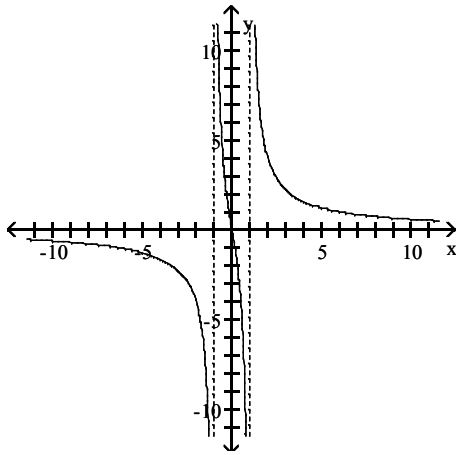

D)

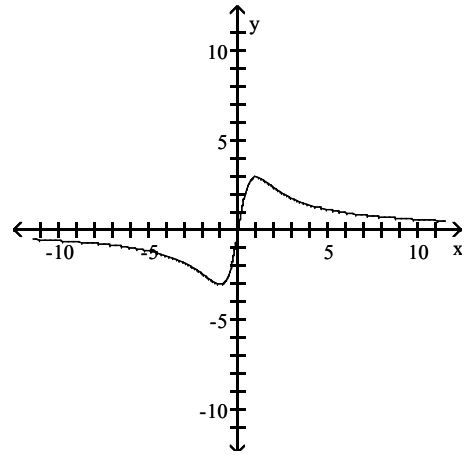

Answer: C

$$251) f(x) = \frac{2x^2}{x^2 - 4}$$

A)

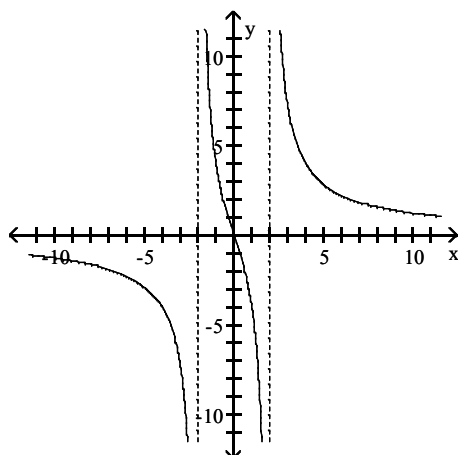

B)

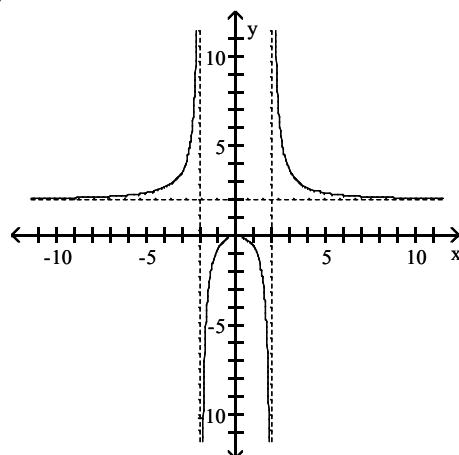

C)

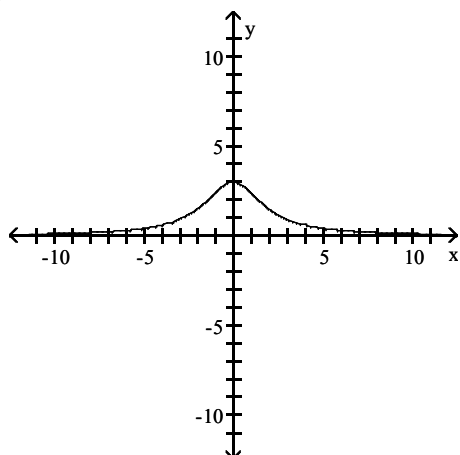

D)

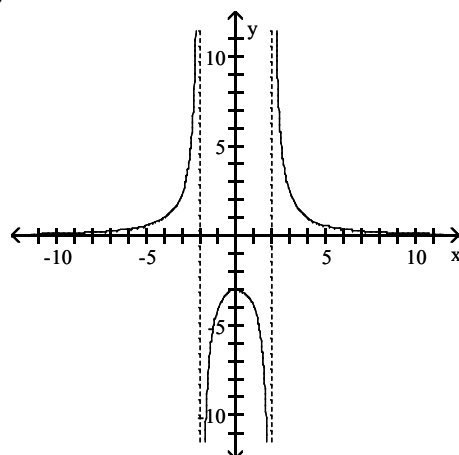

Answer: B

$$252) f(x) = \frac{x^3}{x^2 - 4}$$

A)

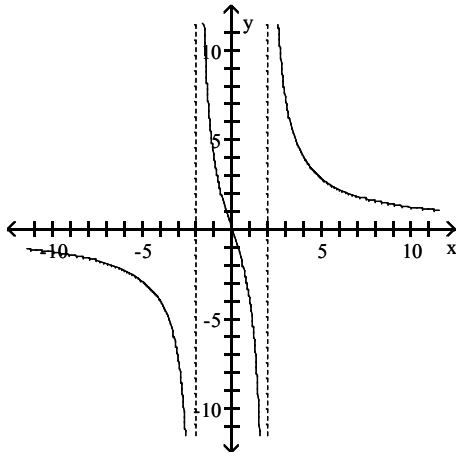

B)

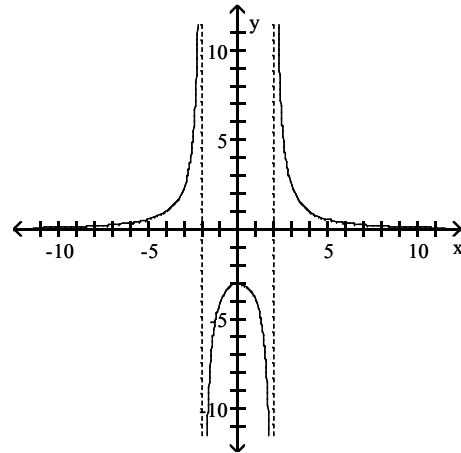

C)

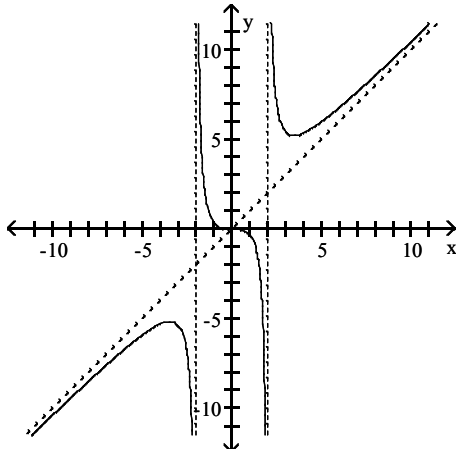

D)

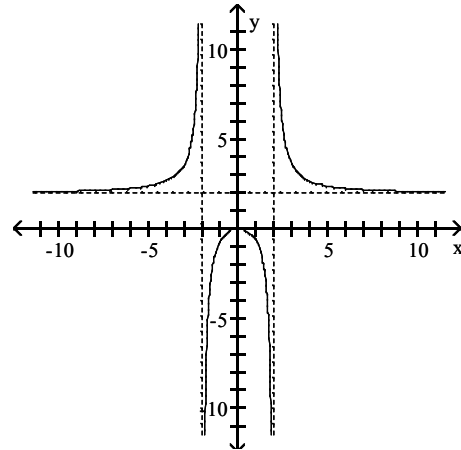

Answer: C

Graph the rational function and find the intercepts.

$$253) f(x) = \frac{3x}{x - 4}$$

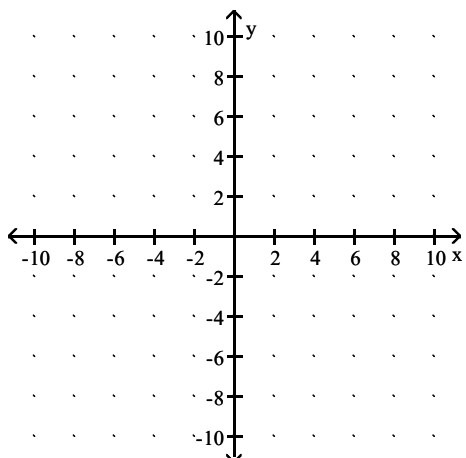

A) x intercept: 0. y-intercept: 0.

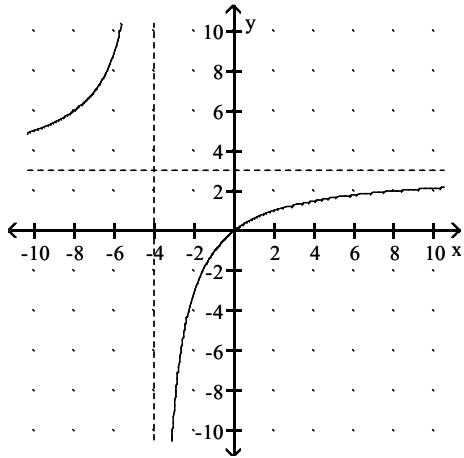

B) x intercept: 3. y-intercept: 0.

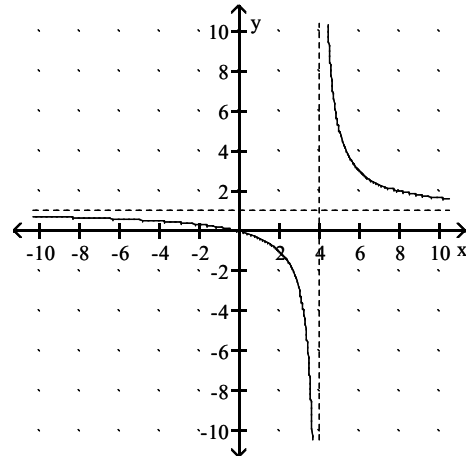

C) x intercept: 0. y-intercept: 3.

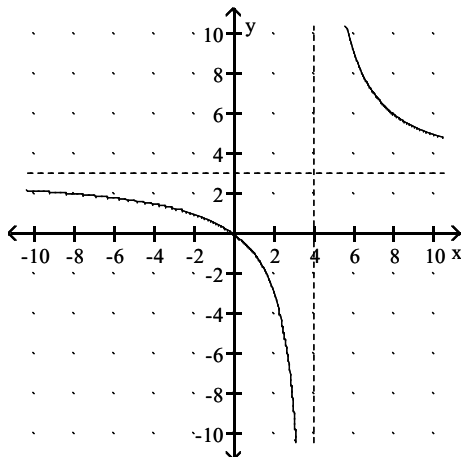

D) x intercept: 0. y-intercept: 0.

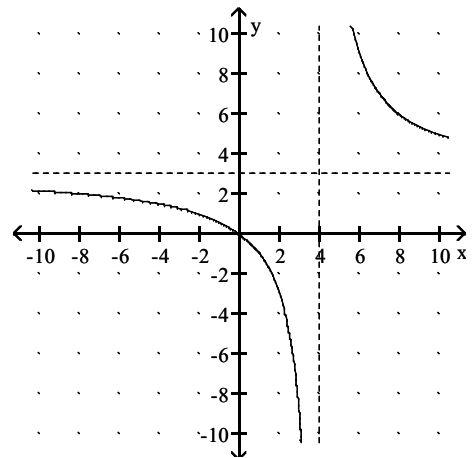

Answer: D

254)  $f(x) = \frac{x}{x^2 - 1}$

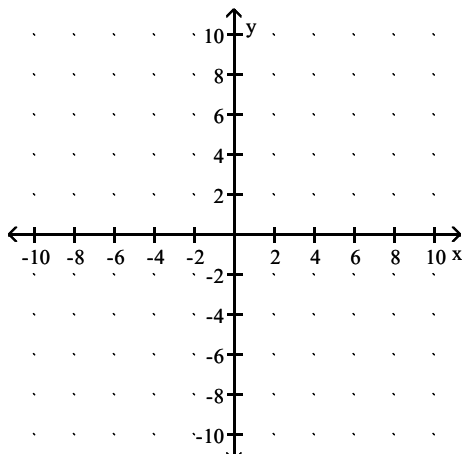

A) x-intercept: 0. y-intercept: 0.

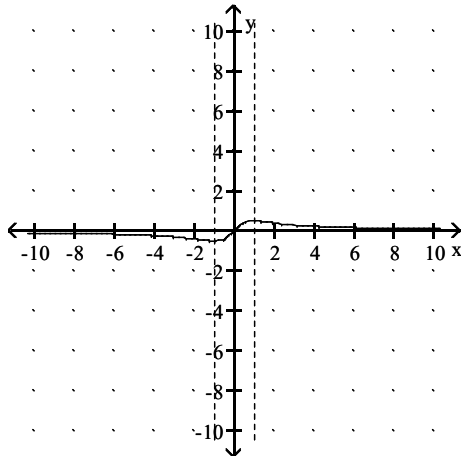

B) x-intercept: 1. y-intercept: 0.

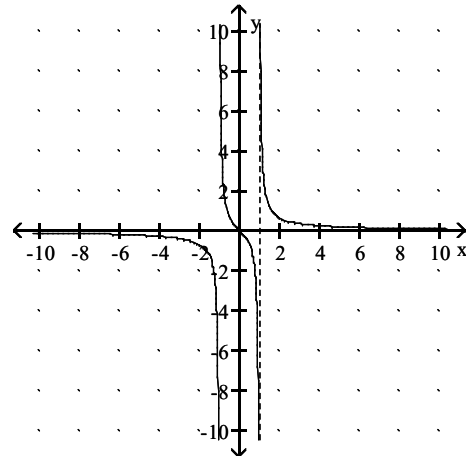

C) x-intercept: 0. y-intercept: 0.

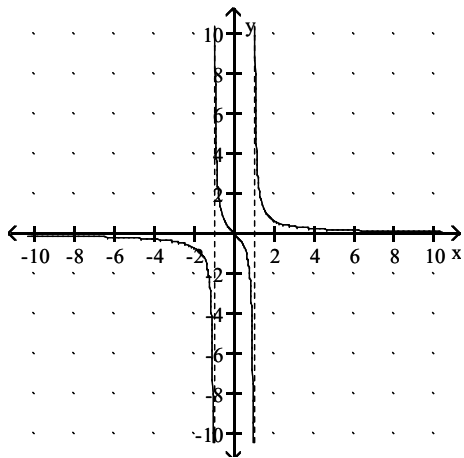

D) x-intercept: 0. y-intercept: 1.

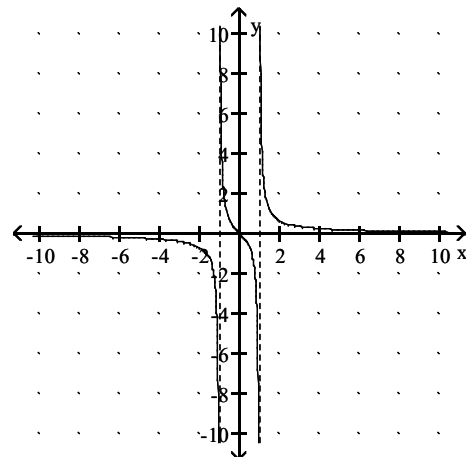

Answer: C

$$255) g(x) = \frac{x^2}{25 - x^2}$$

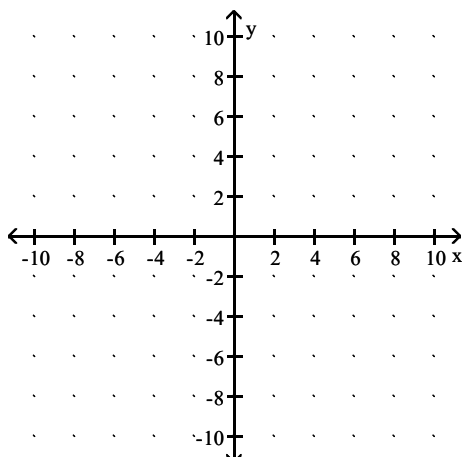

A) x-intercept: 0. y-intercept: -1

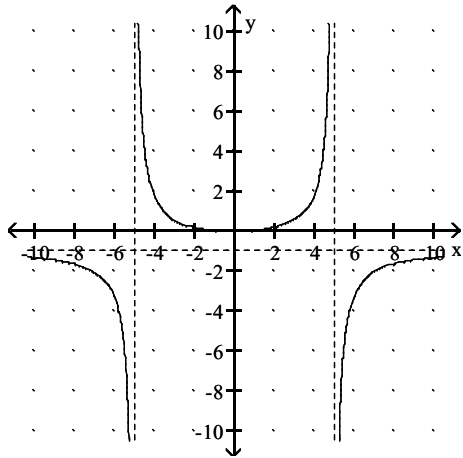

B) x-intercept: 0. y-intercept: 0

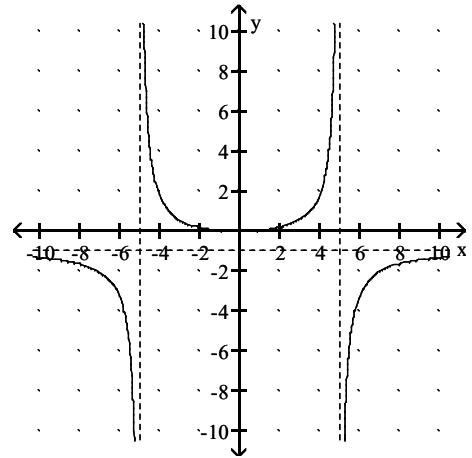

C) x-intercept: 0. y-intercept: 5

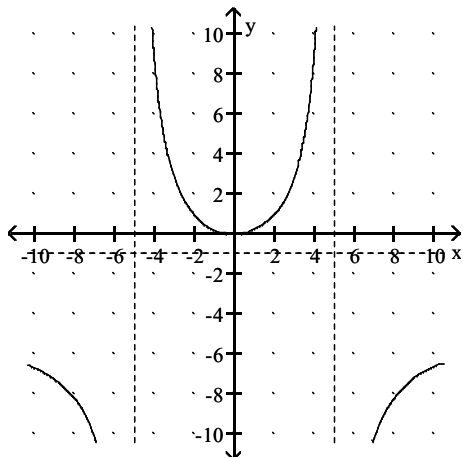

D) x-intercept: 0. y-intercept: 0

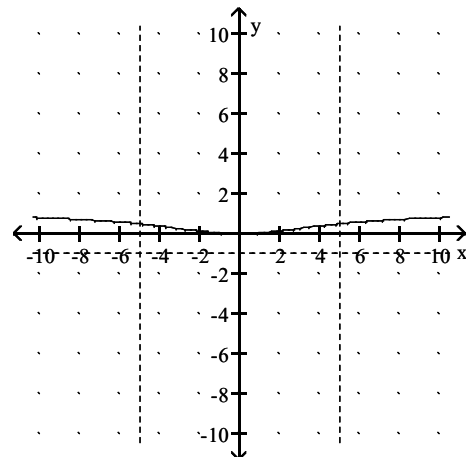

Answer: B

$$256) h(x) = \frac{-3x^2}{x^2 - 1}$$

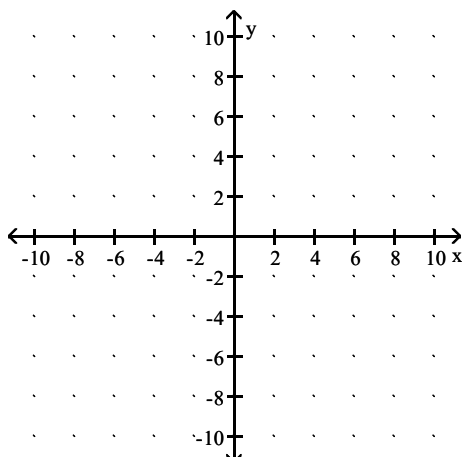

A) x-intercept: 0. y-intercept: 0.

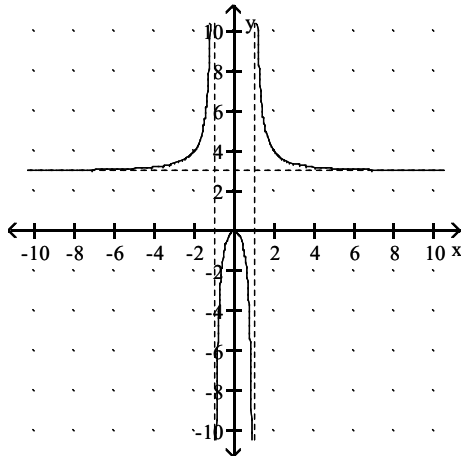

B) x-intercept: 0. y-intercept: 0.

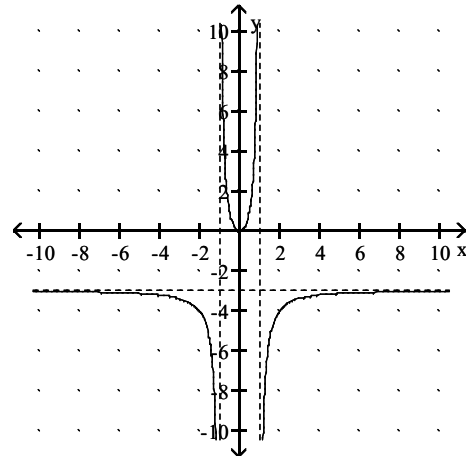

C) x-intercept: 1. y-intercept: 0.

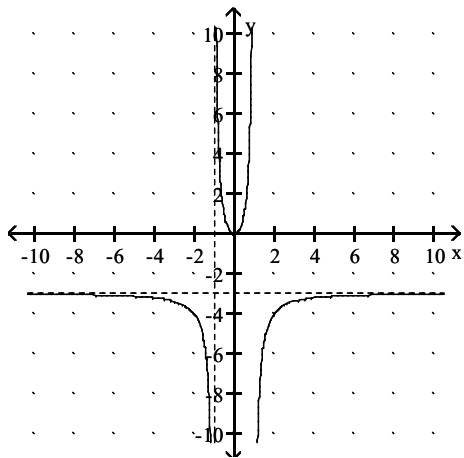

D) x-intercept: 0. y-intercept: -3.

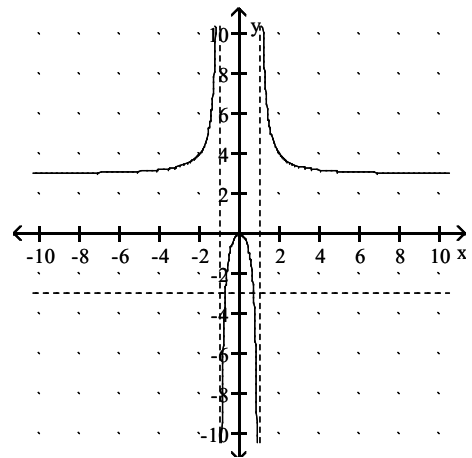

Answer: B

257)  $f(x) = \frac{4}{x^2 - 6}$

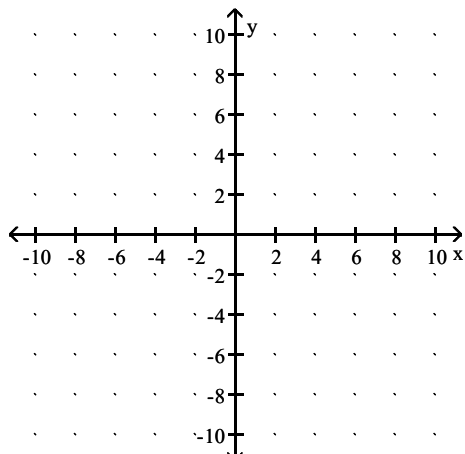

A) No x-intercept. y-intercept:  $\frac{2}{3}$

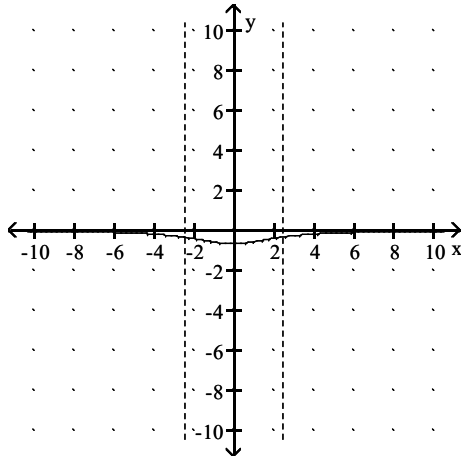

B) No x-intercept. y-intercept:  $\frac{2}{3}$

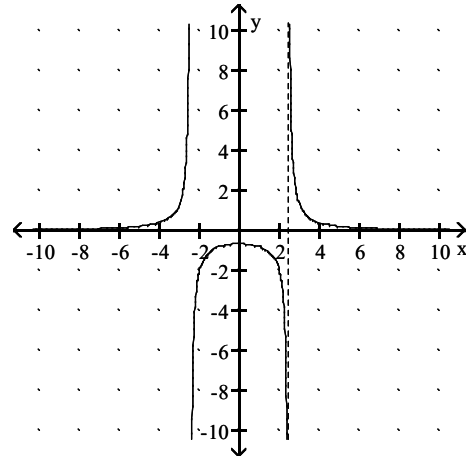

C) No x-intercept. y-intercept:  $-\frac{2}{3}$

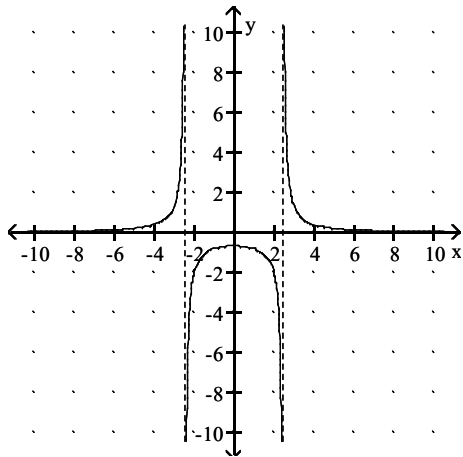

D) x-intercept = 0. y-intercept:  $-\frac{2}{3}$

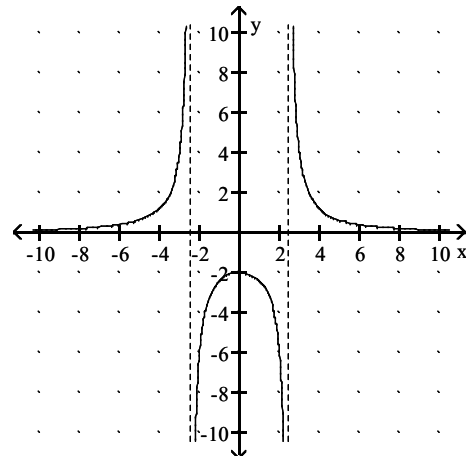

Answer: C

258)  $g(x) = \frac{x - 5}{(x - 2)(x + 8)}$

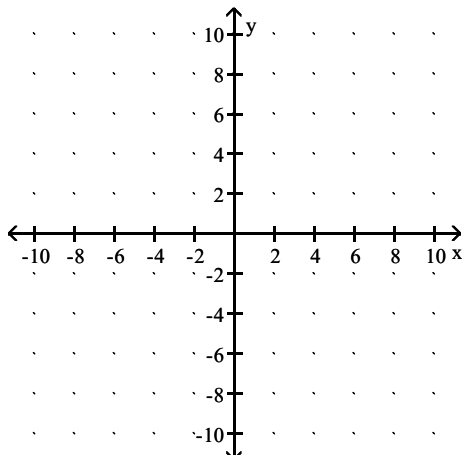



A) x-intercept: 5. y-intercept:  $\frac{5}{16}$ .

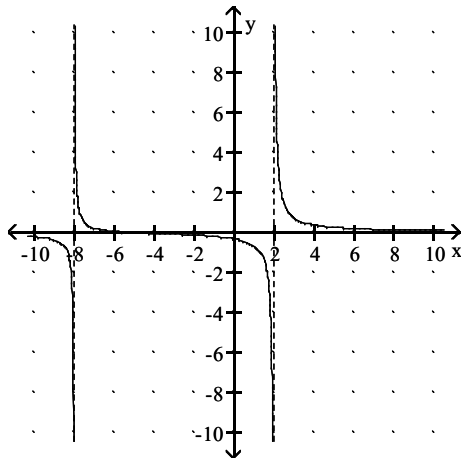

B) x-intercept: 1. y-intercept:  $-\frac{5}{16}$ .

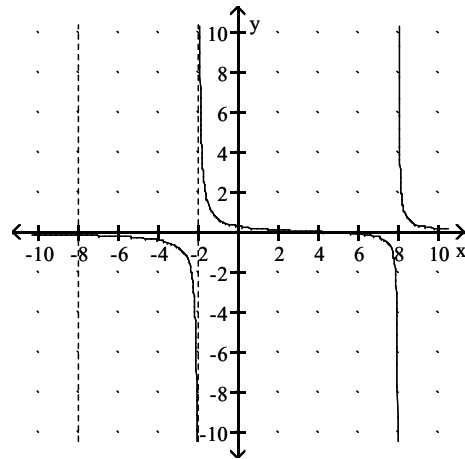

C) x-intercept: 5. y-intercept:  $\frac{5}{16}$ .

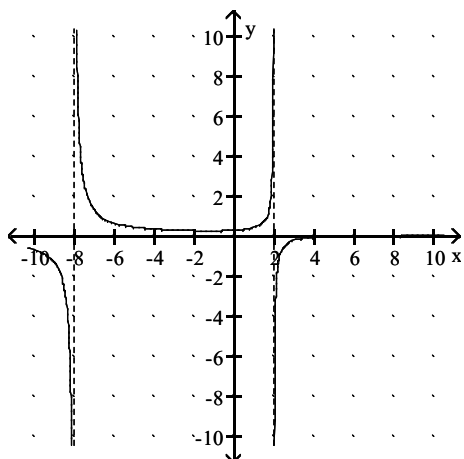

D) x-intercept: 0. y-intercept: 0.

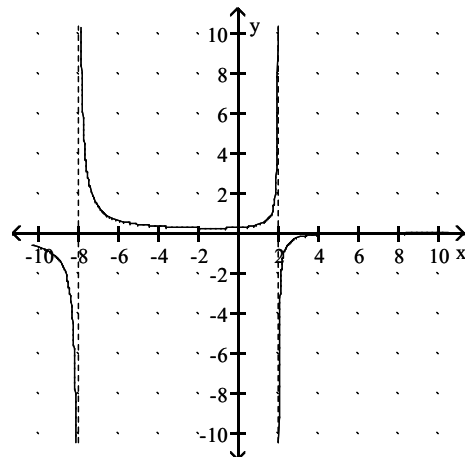

Answer: C

259)  $h(x) = \frac{x^2}{x^2 + 9}$

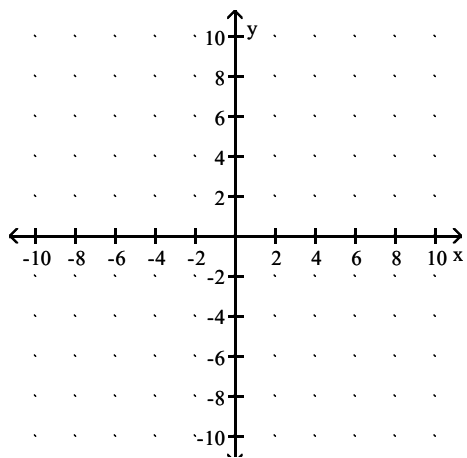

A) x-intercept: 3. y-intercept: 1.

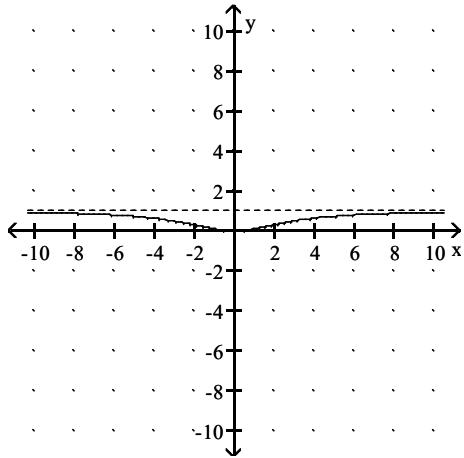

B) x-intercept: 1. y-intercept: 1.

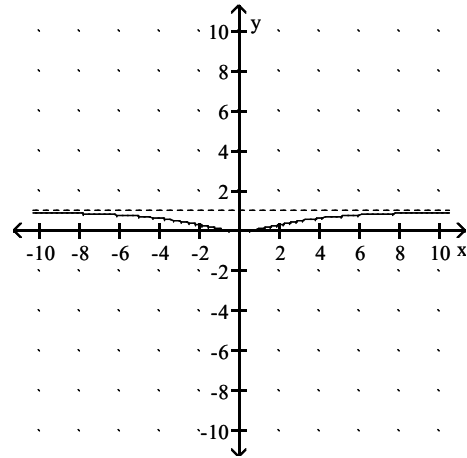

C) x-intercept: 0. y-intercept: 0.

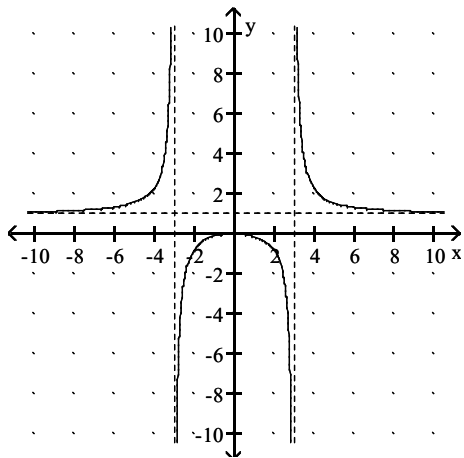

D) x-intercept: 0. y-intercept: 0.

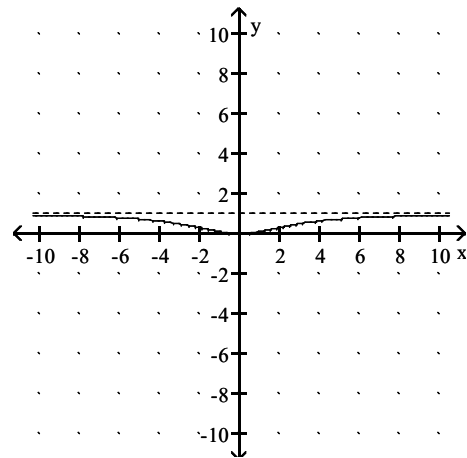

Answer: D

$$260) f(x) = \frac{x^2 - 9}{x^2 - 16}$$

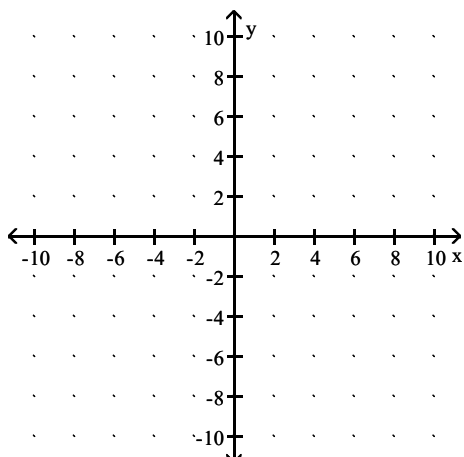

A) x-intercept:  $\pm 3$ . y-intercept:  $\frac{9}{16}$ .

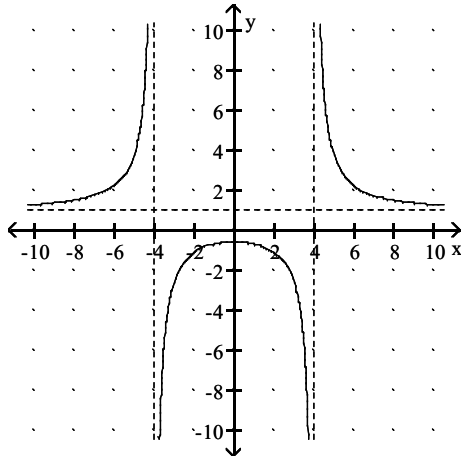

B) x-intercept: 3. y-intercept:  $\frac{3}{4}$ .

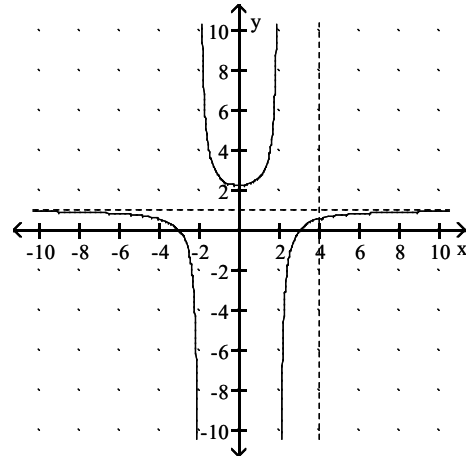

C) x-intercept: 3. y-intercept:  $-\frac{9}{16}$ .

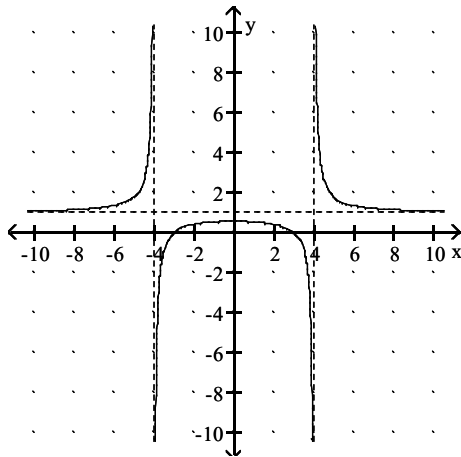

D) x-intercept:  $\pm 3$ . y-intercept:  $\frac{9}{16}$ .

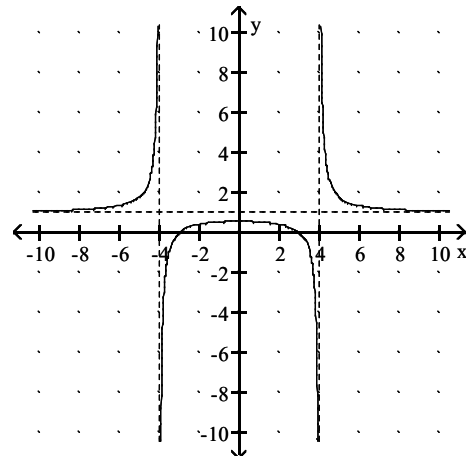

Answer: D

261)  $g(x) = \frac{(x-5)^2}{x-5}$

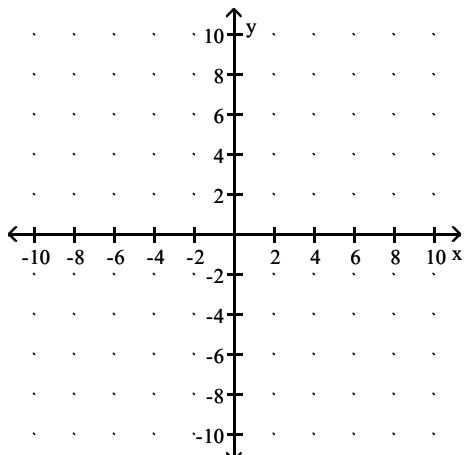

A) no x-intercept. y-intercept: -5

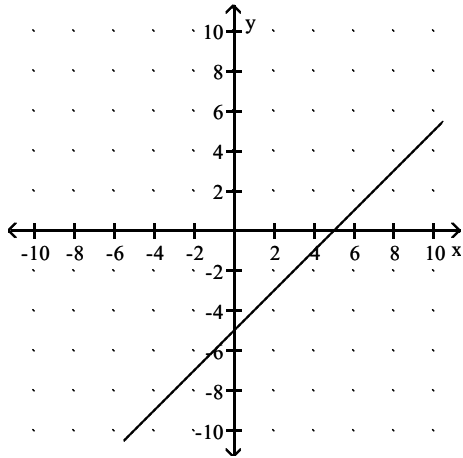

B) x-intercept: 5. y-intercept: -5

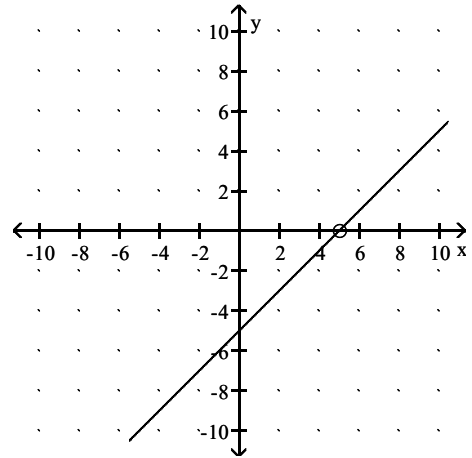

C) no x-intercept. y-intercept: -5

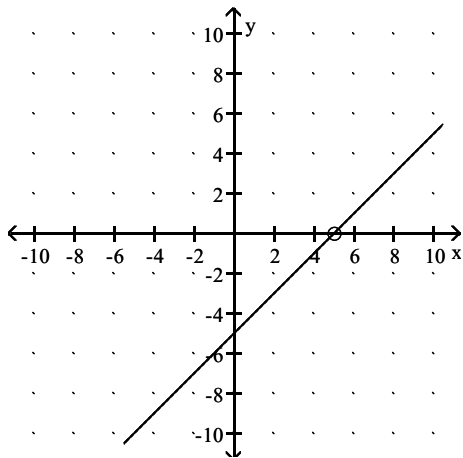

D) x-intercept: 5. y-intercept: 5

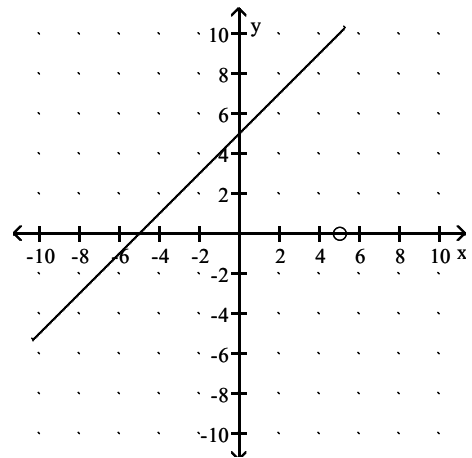

Answer: C

$$262) h(x) = \frac{(x-3)(x+3)(x-1)}{(x-3)(x+3)(x-1)}$$

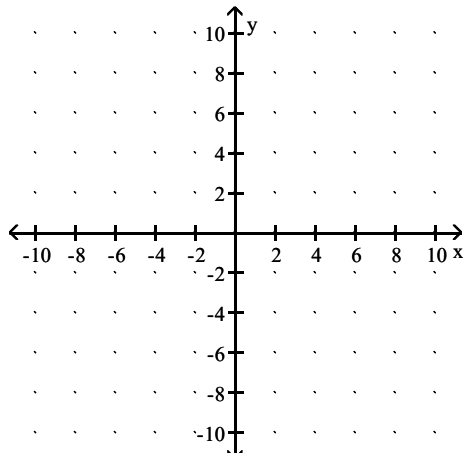

A) No x-intercept. y-intercept: 1.

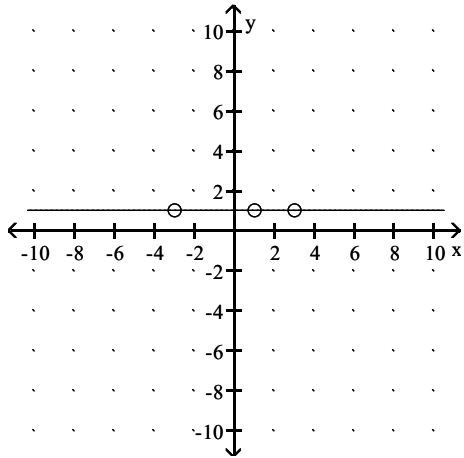

B) No x-intercept. y-intercept: 0.

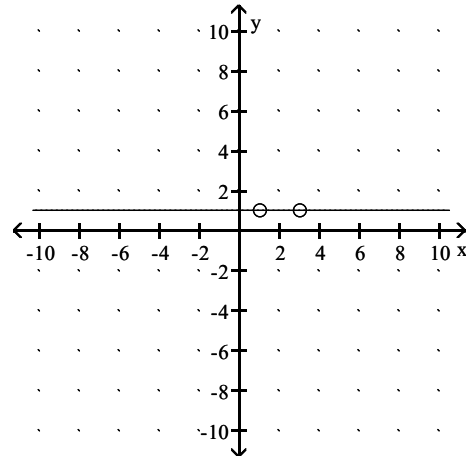

C) x-intercept:  $\pm 3$  and 1. y-intercept: 1.

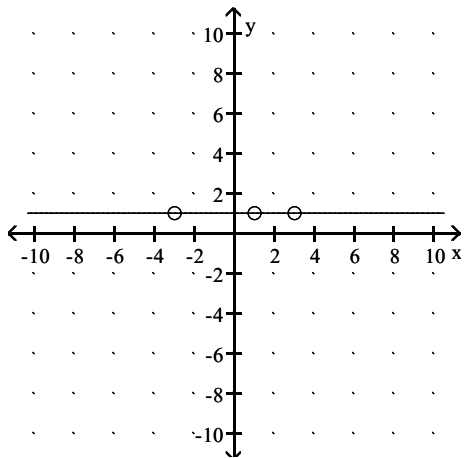

D) No x-intercept. No y-intercept.

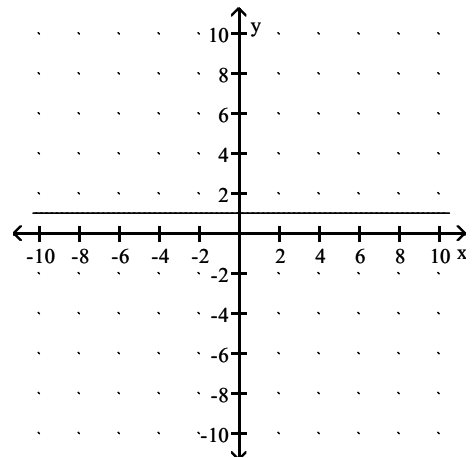

Answer: A

Graph the rational function.

$$263) f(x) = \frac{x^2 - 16}{x + 2}$$

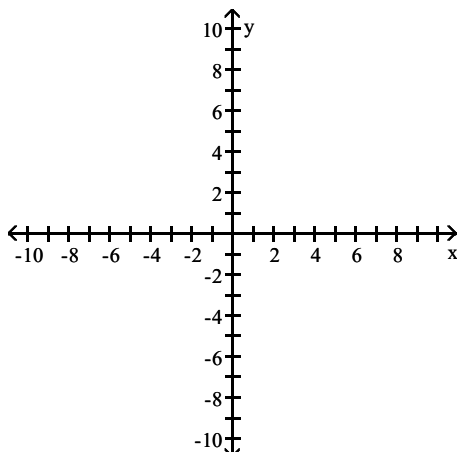

A)

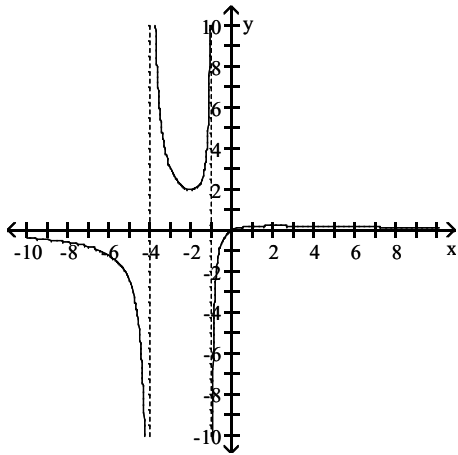

B)

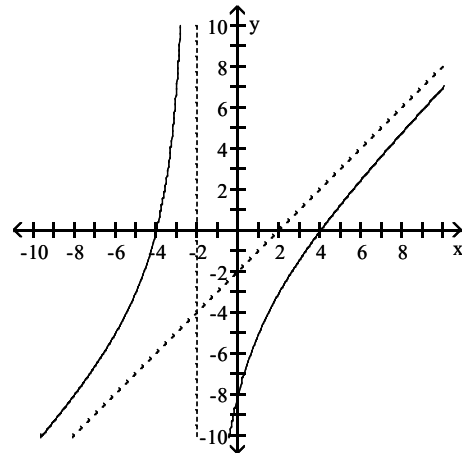

C)

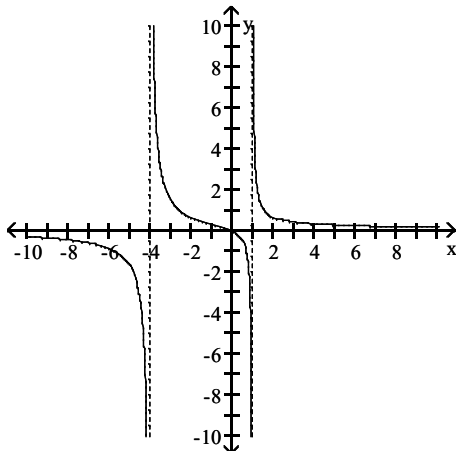

D)

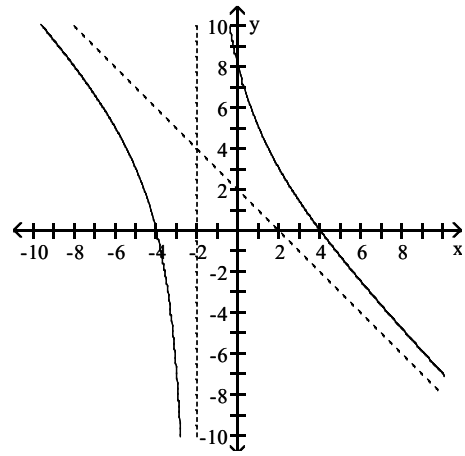

Answer: B

$$264) f(x) = \frac{x^2 - x - 6}{x + 4}$$

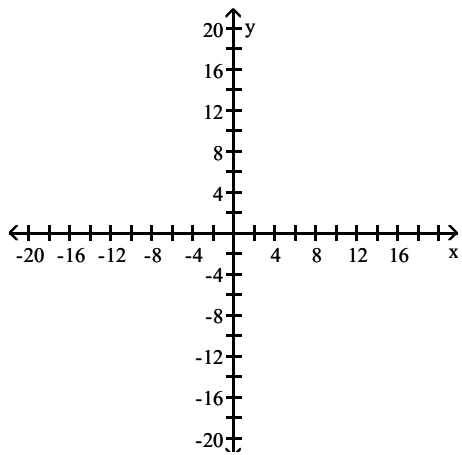

A)

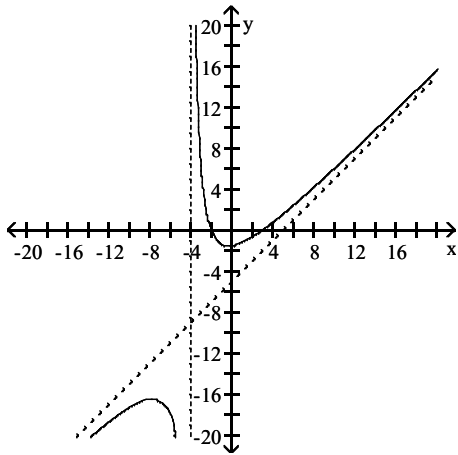

B)

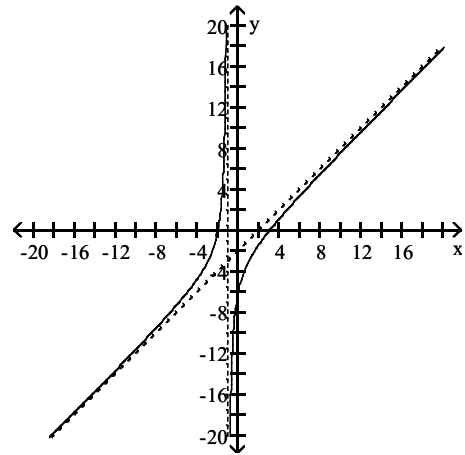

C)

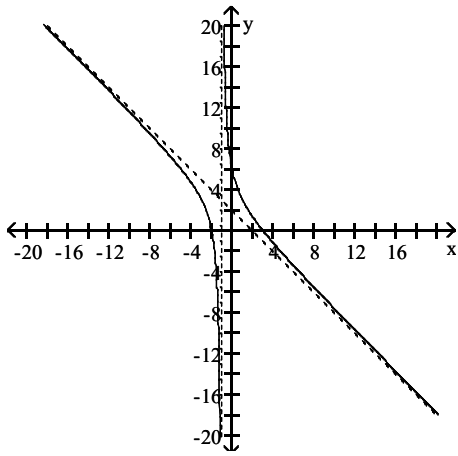

D)

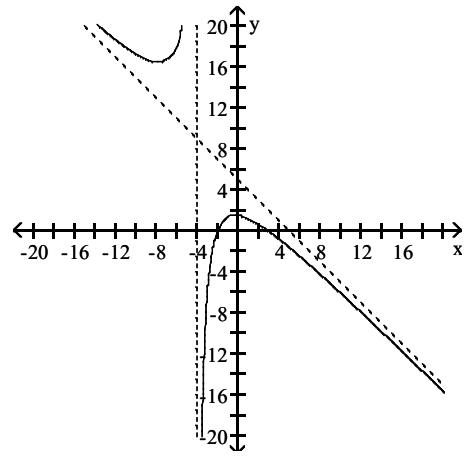

Answer: A

$$265) f(x) = \frac{x^2 + 1}{x + 2}$$

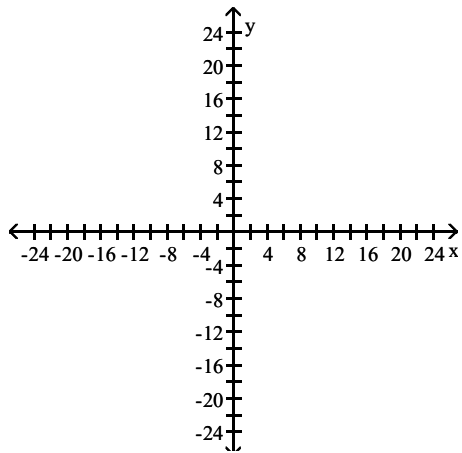

A)

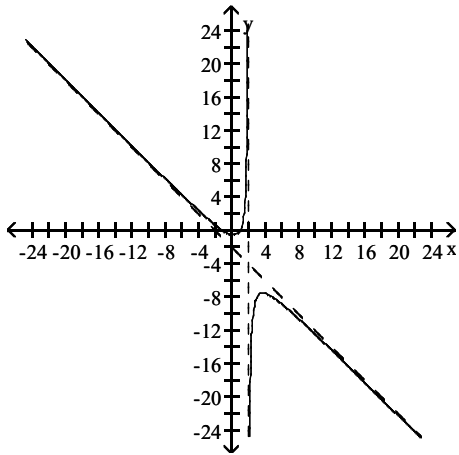

B)

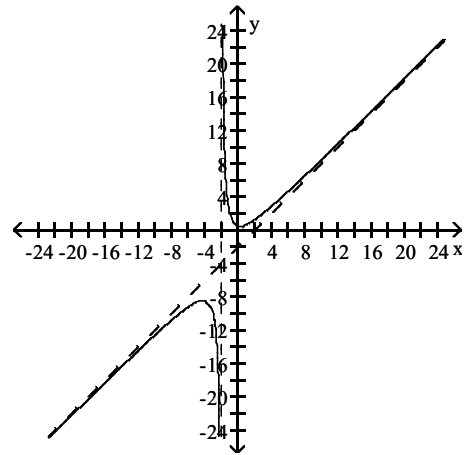

C)

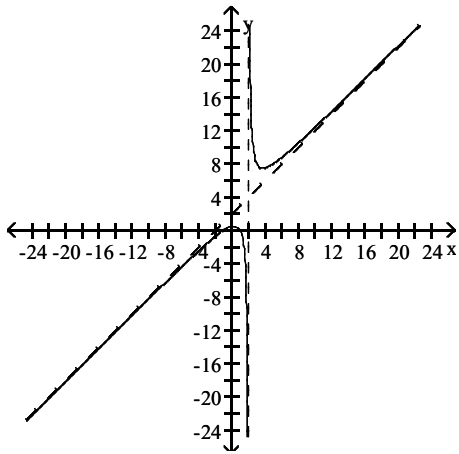

D)

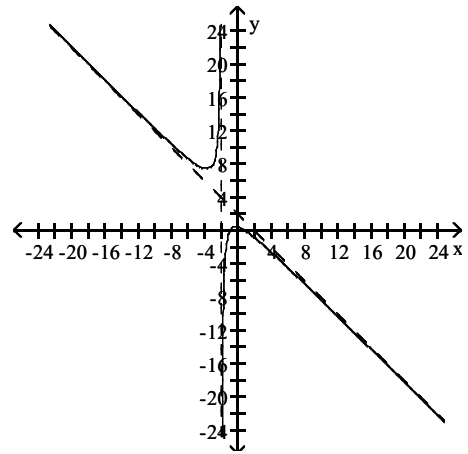

Answer: B

$$266) f(x) = \frac{x^2 + 4x}{x - 1}$$

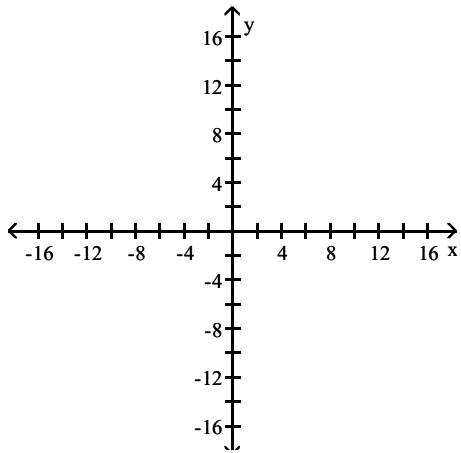



A)

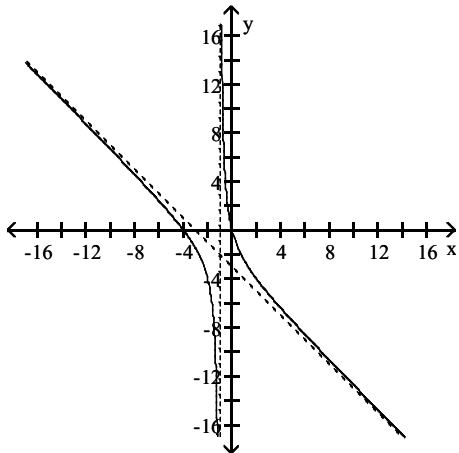

B)

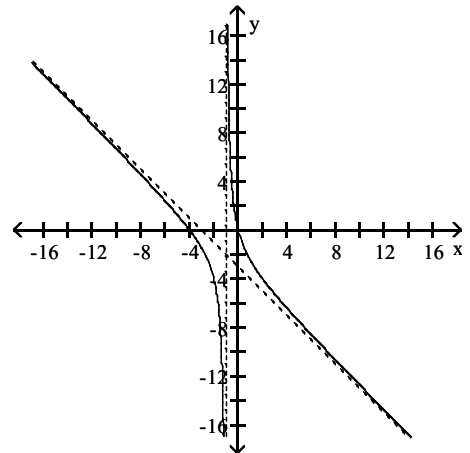

C)

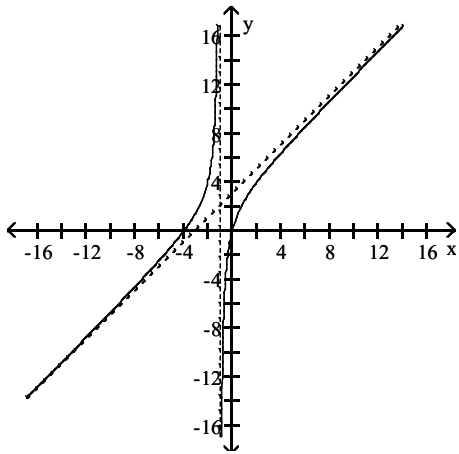

D)

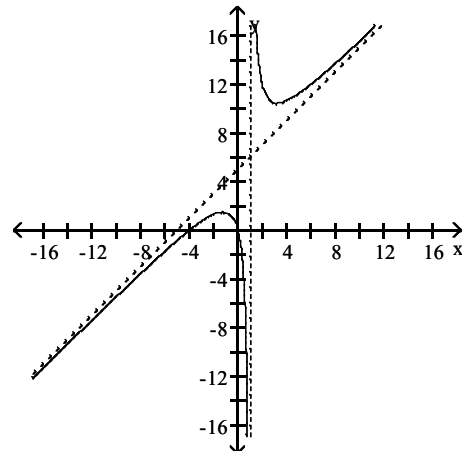

Answer: D

$$267) f(x) = \frac{x^2 + 4}{x}$$

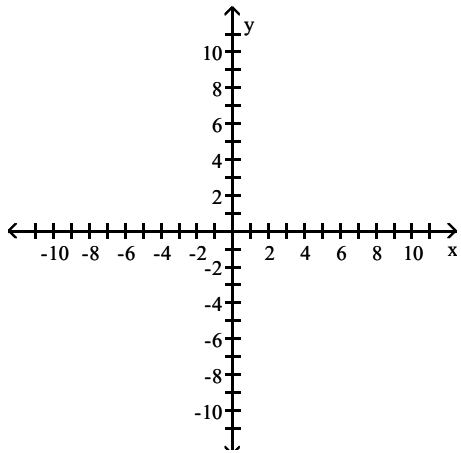

A)

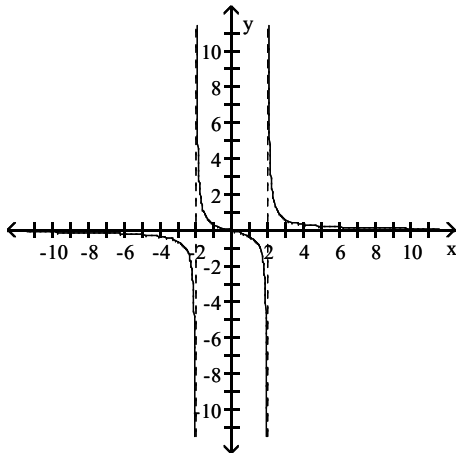

B)

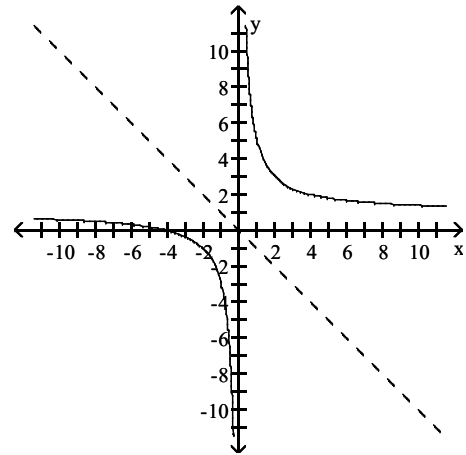

C)

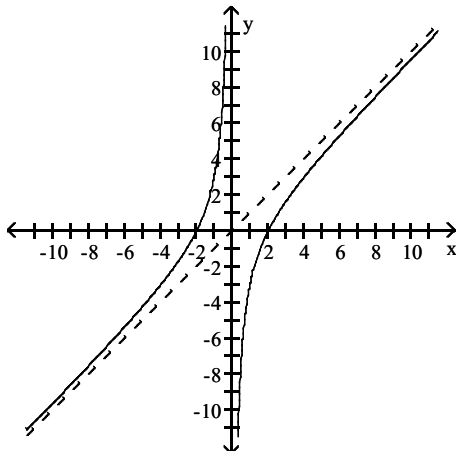

D)

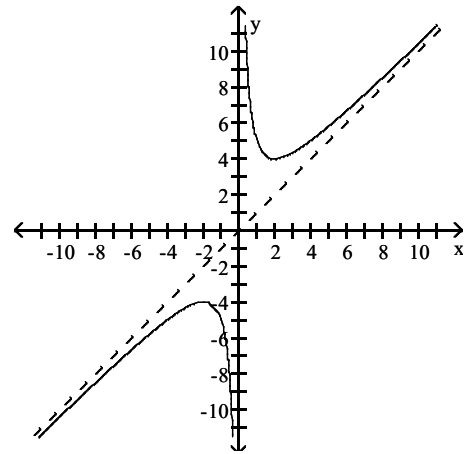

Answer: D

$$268) f(x) = \frac{x^3 + 3}{x^2 + 3x}$$

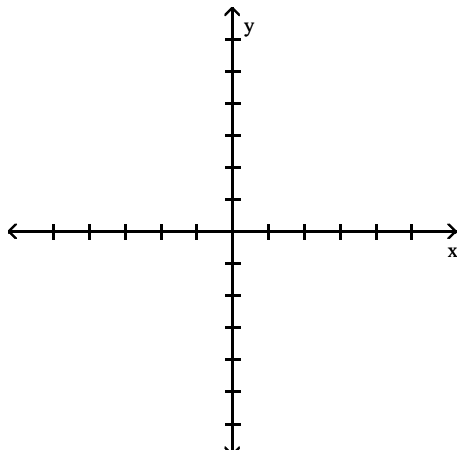

A)

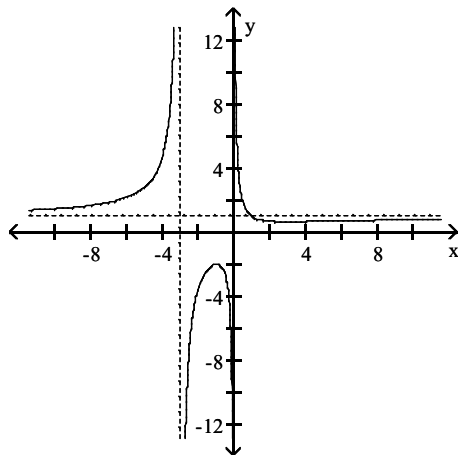

B)

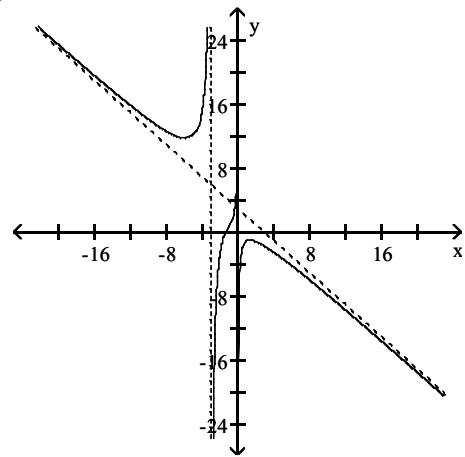

C)

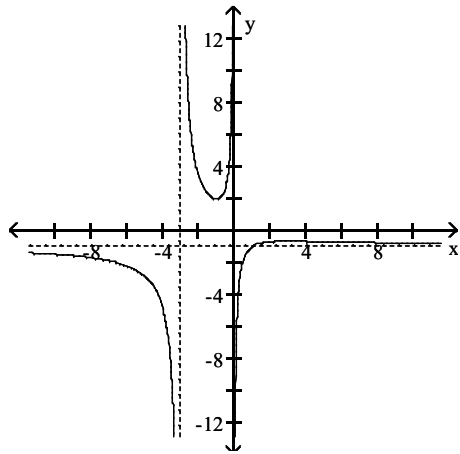

D)

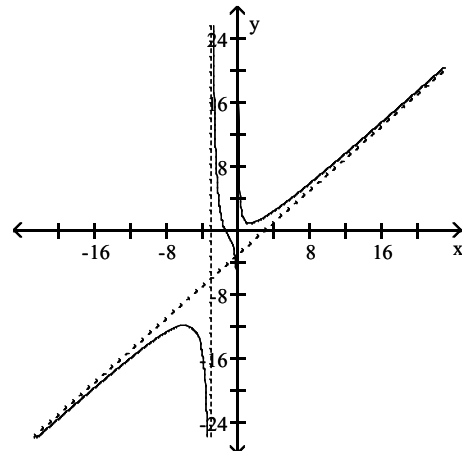

Answer: D

**Solve the problem.**

269) The average cost per tape, in dollars, for a company to produce  $x$  sports videotapes is given by the function

$$A(x) = \frac{12x + 50}{x} \text{ for } x > 0$$

Graph the function on the interval  $(0, \infty)$  and complete the following:

$A(x) \rightarrow$  \_\_\_\_\_ as  $x \rightarrow \infty$ .

A)

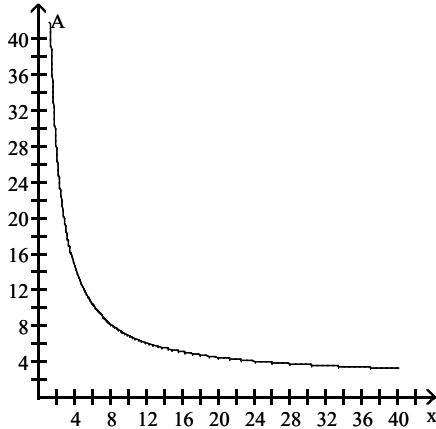

B)

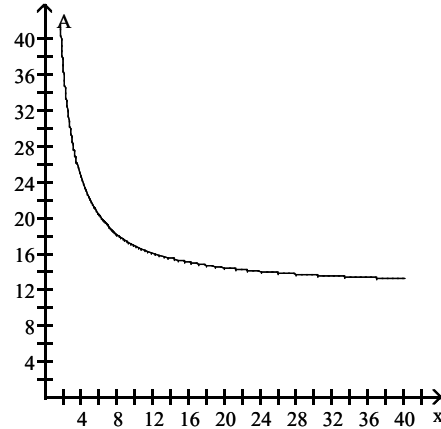

$A(x) \rightarrow 1$  as  $x \rightarrow \infty$ .

C)

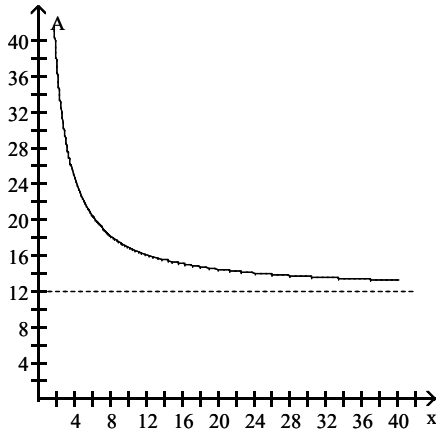

$A(x) \rightarrow 0$  as  $x \rightarrow \infty$ .

D)

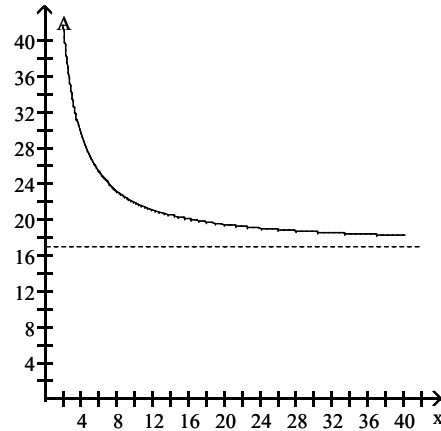

$A(x) \rightarrow 12$  as  $x \rightarrow \infty$ .

$A(x) \rightarrow 17$  as  $x \rightarrow \infty$ .

Answer: C

270) An open-top rectangular box has a square base and it will hold 109 cubic centimeters (cc). Each side of the base has length  $x$  cm, and the box has a height of  $y$  cm. Express the surface area  $S$  as a function of the length  $x$  of a side of the base.

A)  $S(x) = \frac{218}{x} + x^2$

B)  $S(x) = 436 + x^2$

C)  $S(x) = \frac{109}{x} + x^2$

D)  $S(x) = \frac{436}{x} + x^2$

Answer: D

271) An open-top rectangular box has a square base and it will hold 256 cubic centimeters (cc). Each side of the base has length  $x$  cm. The box's surface area  $S$  is given by  $S(x) = \frac{1024}{x} + x^2$ . Estimate the minimum surface area and the value of  $x$  that will yield it.

- A)  $192 \text{ cm}^2$  when  $x = 8$  cm  
 B)  $256 \text{ cm}^2$  when  $x = 6$  cm  
 C)  $207 \text{ cm}^2$  when  $x = 6$  cm  
 D)  $256 \text{ cm}^2$  when  $x = 8$  cm

Answer: A

272) Suppose a cost-benefit model is given by  $y = \frac{8.8x}{100 - x}$ , where  $y$  is the cost in thousands of dollars for removing  $x$  percent of a given pollutant. Find the cost of removing 45% to the nearest dollar.

- A) \$7200  
 B) \$3960  
 C) \$8800  
 D) \$818

Answer: A

273) The average number of vehicles waiting in line at a toll booth of a super highway is modeled by the function

$n(x) = \frac{x^2}{0.5(1-x)}$ , where  $x$  is a quantity between 0 and 1 known as the traffic intensity. What happens to the

average number of vehicles waiting as traffic intensity increases?

- A) The average number of vehicles waiting decreases at first, but then increases.  
 B) The average number of vehicles waiting increases.  
 C) The average number of vehicles waiting remains constant.  
 D) The average number of vehicles waiting decreases.

Answer: B

274) The resistance, in ohms, of a 25 foot piece of wire is given by the function  $R(d) = \frac{0.025}{d^2}$ , where  $d$  is the diameter

of the wire in inches. What happens to the resistance of the wire as the diameter of the wire decreases?

- A) The resistance remains constant.  
 B) The resistance increases.  
 C) The resistance decreases.  
 D) The answer cannot be determined without additional information.

Answer: B

275) The concentration of a drug in the bloodstream, measured in milligrams per liter, can be modeled by the function,  $C(t) = \frac{12t + 4}{3t^2 + 2}$ , where  $t$  is the number of minutes after injection of the drug. When will the drug be at its

highest concentration? Approximate your answer rounded to two decimal places.

- A)  $t = 4$  minutes after the injection is given  
 B)  $t = 3.65$  minutes after the injection is given  
 C)  $t = 0.55$  minutes after the injection is given  
 D) at the time of injection

Answer: C



280)  $P(x) < 0$

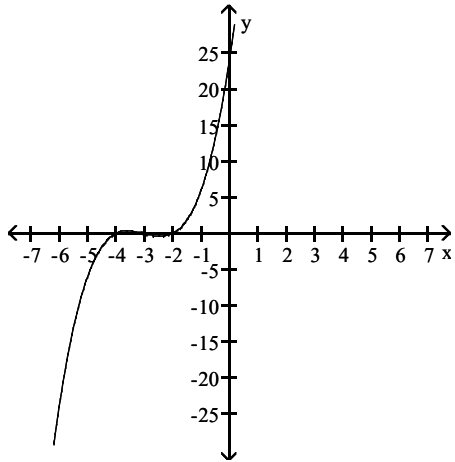

A)  $(-4, -3) \cup (-2, \infty)$

B)  $(-\infty, -3)$

C)  $(-\infty, -4) \cup (-3, -2)$

D)  $(-2, \infty)$

Answer: C

281)  $P(x) > 0$

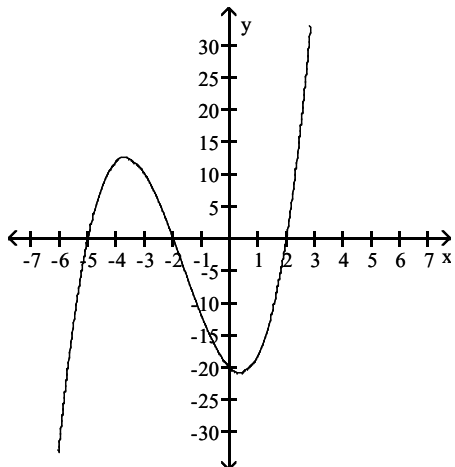

A)  $(-\infty, -2) \cup (2, \infty)$

B)  $(-5, 2)$

C)  $(-5, -2) \cup (2, \infty)$

D)  $(-\infty, 2) \cup (2, 5)$

Answer: C

282)  $P(x) > 0$

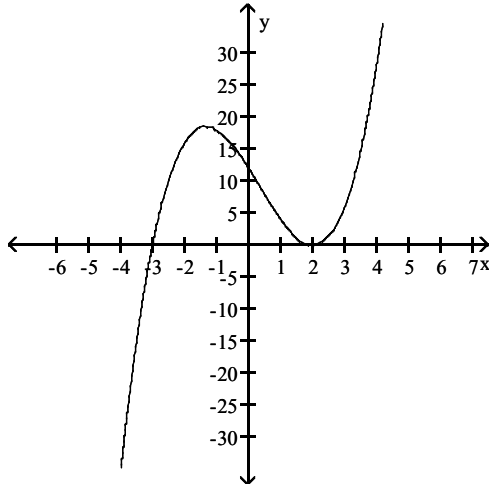

A)  $(-3, 2) \cup (2, \infty)$

B)  $(-\infty, \infty)$

C)  $(-3, \infty)$

D)  $(-3, -2) \cup (-2, \infty)$

Answer: A

283)  $P(x) \leq 0$

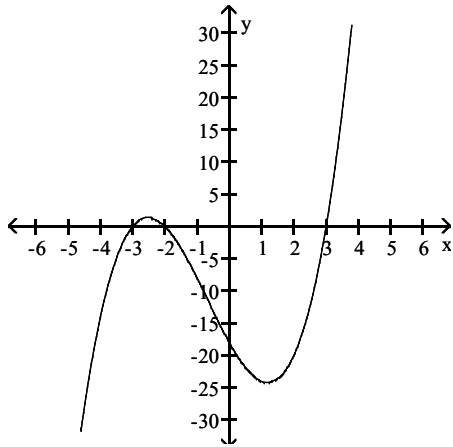

A)  $(-\infty, -3] \cup [-2, 3]$

B)  $(-\infty, -3] \cup [-2, \infty)$

C)  $[-3, -2] \cup [3, \infty)$

D)  $[-2, 3]$

Answer: A

284)  $P(x) > 0$

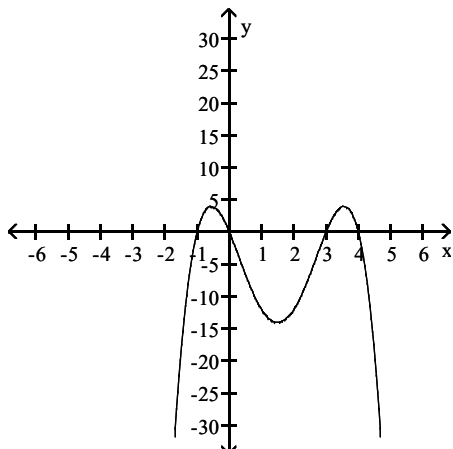

A)  $(3, 4)$

B)  $(-1, 0) \cup (3, 4)$

C)  $(-\infty, -1) \cup (0, 3)$

D)  $(-1, 0) \cup (3, \infty)$

Answer: B



**Solve the polynomial inequality.**

285)  $(x - 1)(x - 5) > 0$

A)  $(-\infty, 1)$

B)  $(5, \infty)$

C)  $(1, 5)$

D)  $(-\infty, 1) \cup (5, \infty)$

Answer: D

286)  $(x + 1)(x - 7) \leq 0$

A)  $(-\infty, -1]$

B)  $[-1, 7]$

C)  $[7, \infty)$

D)  $(-\infty, -1] \cup [7, \infty)$

Answer: B

287)  $x(x + 3)(5 - x) \geq 0$

A)  $(-\infty, -3] \cup [0, 5]$

B)  $[-3, 5]$

C)  $[-3, 0] \cup [5, \infty)$

D)  $[0, 5]$

Answer: A

288)  $(x + 9)(x + 4)(x - 3) > 0$

A)  $(-9, -4) \cup (3, \infty)$

B)  $(3, \infty)$

C)  $(-\infty, -9) \cup (-4, 3)$

D)  $(-\infty, -4)$

Answer: A

289)  $(x + 5)(x + 4)(x + 3) < 0$

A)  $(-5, -4) \cup (-3, \infty)$

B)  $(-3, \infty)$

C)  $(-\infty, -4)$

D)  $(-\infty, -5) \cup (-4, -3)$

Answer: D

290)  $(x + 10)(x - 9)(x + 9) \geq 0$

A)  $(-\infty, -9] \cup [9, \infty)$

B)  $(-\infty, 9] \cup [9, 10]$

C)  $[-10, 9]$

D)  $[-10, -9] \cup [9, \infty)$

Answer: D

291)  $(x + 1)(x - 5)^2 > 0$

A)  $(-1, \infty)$

B)  $(-1, -5) \cup (-5, \infty)$

C)  $(-1, 5) \cup (5, \infty)$

D)  $(-\infty, \infty)$

Answer: C

292)  $(2x + 1)(x - 3)(3x - 1) \leq 0$

A)  $\left(-\infty, -\frac{1}{2}\right) \cup \left[\frac{1}{3}, 3\right]$

B)  $\left[-\infty, -\frac{1}{2}\right] \cup \left[\frac{1}{3}, 3\right]$

C)  $\left[-\frac{1}{2}, \frac{1}{3}\right] \cup [3, \infty)$

D)  $\left[-\frac{1}{2}, \frac{1}{3}\right) \cup (3, \infty)$

Answer: B

293)  $(x + 7)^2(2x + 3)(x - 2) > 0$

A)  $(-\infty, -6) \cup (-6, -7) \cup (2, \infty)$

C)  $(-\infty, -1.5) \cup (2, \infty)$

B)  $(-\infty, -7) \cup (-7, -1.5) \cup (2, \infty)$

D)  $[-7, -1.5) \cup (2, \infty)$

Answer: B

294)  $x^2 - 9x + 14 > 0$

A)  $(-\infty, 2) \cup (7, \infty)$

B)  $(-\infty, 2)$

C)  $(7, \infty)$

D)  $(2, 7)$

Answer: A

295)  $x^2 - 2x - 3 < 0$

A)  $(-\infty, -1)$

B)  $(3, \infty)$

C)  $(-1, 3)$

D)  $(-\infty, -1) \cup (3, \infty)$

Answer: C

296)  $x^2 - 4x - 12 \leq 0$

A)  $[-2, 6]$

B)  $(-\infty, -2] \cup [6, \infty)$

C)  $(-\infty, -2]$

D)  $[6, \infty)$

Answer: A

297)  $x^2 + 3x - 18 \geq 0$

A)  $[-6, 3]$

B)  $(-\infty, -6] \cup [3, \infty)$

C)  $(-\infty, -6]$

D)  $[3, \infty)$

Answer: B

298)  $x^2 - 2x \leq 3$

A)  $[-3, 1]$

B)  $[-1, 3]$

C)  $(-\infty, -3] \cup [1, \infty)$

D)  $(-3, 1)$

Answer: B

299)  $x^2 + 2x \geq 0$

A)  $[0, 2]$

B)  $(-\infty, 0] \cup [2, \infty)$

C)  $(-\infty, \infty)$

D)  $(-\infty, -2] \cup [0, \infty)$

Answer: D

300)  $4x^2 + 49 < 28x$

A)  $\left(-\infty, \frac{7}{2}\right)$

B)  $\emptyset$

C)  $\left(-\infty, -\frac{7}{2}\right)$

D)  $\left(-\frac{7}{2}, \infty\right)$

Answer: B

301)  $2x^3 + 3x^2 - 50x - 75 > 0$

A)  $(-\infty, -5] \cup \left[-\frac{3}{2}, 5\right)$

B)  $\left[-5, -\frac{3}{2}\right] \cup [5, \infty)$

C)  $(-\infty, -5) \cup \left[-\frac{3}{2}, 5\right)$

D)  $\left[-5, -\frac{3}{2}\right] \cup (5, \infty)$

Answer: D

302)  $x^3 + 4x^2 - 4x - 16 \geq 0$

A)  $[-2, 2] \cup [4, \infty)$

B)  $[-4, -2] \cup [2, \infty)$

C)  $[-4, 2]$

D)  $[-4, \infty)$

Answer: B

303)  $x^4 - 145x^2 + 5184 < 0$

A)  $(-9, -8) \cup (8, \infty)$

B)  $(-9, -8) \cup (8, 9)$

C)  $(-\infty, -8) \cup (8, \infty)$

D)  $(-9, 9)$

Answer: B

304)  $x^4 - 6x^3 - 109x^2 + 474x + 2160 \leq 0$

A)  $[-9, 10]$

B)  $(-9, -3) \cup [8, 10]$

C)  $[-9, -3] \cup [8, 10]$

D)  $[-9, -3] \cup (8, 10)$

Answer: C

Use the graph of the rational function to solve the indicated inequality.

305)  $R(x) \geq 0$

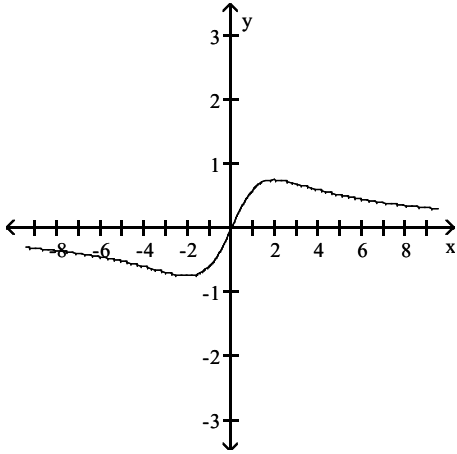

A)  $(-\infty, 2) \cup (2, \infty)$

B)  $(-\infty, 0]$

C)  $[0, \infty)$

D)  $(0, \infty)$

Answer: C

306)  $R(x) < 0$

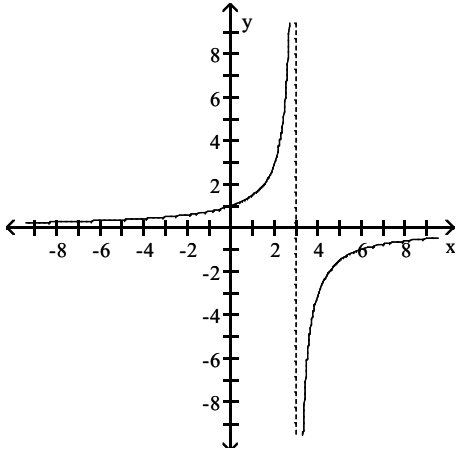

A)  $(-\infty, 3) \cup (3, \infty)$

B)  $(-\infty, 3)$

C)  $(3, \infty)$

D)  $(-\infty, \infty)$

Answer: C

307)  $R(x) > 0$

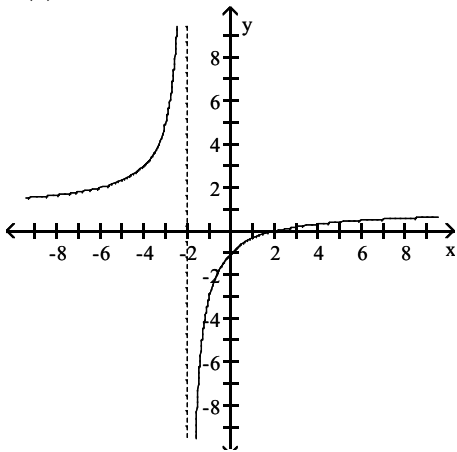

A)  $(-2, \infty)$

B)  $(-\infty, -2) \cup (2, \infty)$

C)  $(-\infty, -2] \cup [2, \infty)$

D)  $(-\infty, -2)$

Answer: B

308)  $R(x) \leq 0$

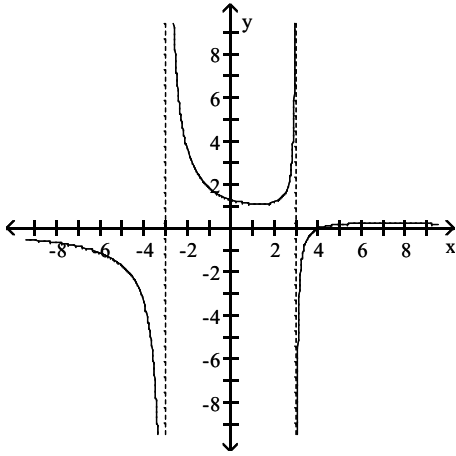

A)  $(-\infty, 3] \cup [3, 4)$

B)  $(-3, 3) \cup (4, \infty)$

C)  $(-\infty, -3) \cup (3, 4]$

D)  $(-3, 3) \cup [4, \infty)$

Answer: C

309)  $R(x) > 0$

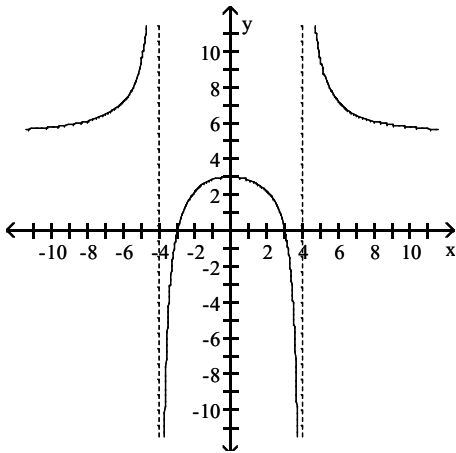

A)  $(0, \infty)$

C)  $(-4, -3) \cup (3, 4)$

B)  $(-\infty, -4) \cup (-3, 3) \cup (4, \infty)$

D)  $(-\infty, -4) \cup (4, \infty)$

Answer: B

**Solve the rational inequality.**

310)  $\frac{-3}{-5x - 7} > 0$

A)  $\left(-\frac{7}{5}, \infty\right)$

B)  $(0, \infty)$

C)  $\left(-\infty, -\frac{5}{7}\right)$

D)  $\left(-\infty, \frac{7}{5}\right)$

Answer: A

311)  $\frac{x - 9}{x + 2} < 0$

A)  $(-2, 9)$

B)  $(-\infty, -2)$

C)  $(-\infty, -2) \cup (9, \infty)$

D)  $(9, \infty)$

Answer: A

312)  $\frac{x-1}{x+5} > 0$   
 A)  $(1, \infty)$                       B)  $(-5, 1)$                       C)  $(-\infty, -5)$                       D)  $(-\infty, -5) \cup (1, \infty)$

Answer: D

313)  $\frac{8-4x}{3x+7} \leq 0$   
 A)  $\left[-\infty, -\frac{7}{3}\right) \cup [2, \infty)$                       B)  $\left[-\infty, -\frac{7}{3}\right) \cup [2, \infty)$                       C)  $\left[-\frac{7}{3}, 2\right]$                       D)  $[2, \infty)$

Answer: B

314)  $\frac{7x+4}{6-2x} \geq 0$   
 A)  $\left[-\frac{4}{7}, \infty\right)$                       B)  $\left[-\frac{4}{7}, 3\right]$                       C)  $\left[-\infty, -\frac{4}{7}\right) \cup (3, \infty)$                       D)  $\left[-\frac{4}{7}, 3\right]$

Answer: B

315)  $\frac{(x-9)(x+9)}{x} \leq 0$   
 A)  $[-9, 0) \cup (0, 9]$                       B)  $(-\infty, -9] \cup (0, 9]$                       C)  $[-9, 0) \cup [9, \infty)$                       D)  $(-\infty, -9] \cup [9, \infty)$

Answer: B

316)  $\frac{(x+12)(x-6)}{x-1} \geq 0$   
 A)  $[-12, 1) \cup [6, \infty)$                       B)  $(-\infty, -12] \cup [6, \infty)$                       C)  $(-\infty, -12] \cup (1, 6]$                       D)  $[-12, 1) \cup (1, 6]$

Answer: A

317)  $\frac{(x-1)(3-x)}{(x-2)^2} \leq 0$   
 A)  $(-\infty, -3) \cup (-1, \infty)$                       B)  $(-\infty, -3] \cup (-2, -1) \cup [1, \infty)$   
 C)  $(-\infty, 1) \cup (3, \infty)$                       D)  $(-\infty, 1] \cup [3, \infty)$

Answer: D

318)  $\frac{1}{(x+8)^2} < 0$   
 A)  $\emptyset$                       B)  $(-7, \infty)$                       C)  $(-8, \infty)$                       D)  $(-\infty, \infty)$

Answer: A

319)  $\frac{x^2(x-11)(x+2)}{(x-4)(x+9)} \geq 0$   
 A)  $(-9, -2] \cup (4, 11]$                       B)  $(-\infty, -9) \cup [11, \infty)$   
 C)  $(-\infty, -9) \cup [-2, 4) \cup [11, \infty)$                       D)  $(-\infty, -9) \cup [-2, 0) \cup (0, 4) \cup [11, \infty)$

Answer: C

$$320) \frac{x-4}{x+2} < 1$$

$$A) (-\infty, -2) \cup (4, \infty)$$

$$B) (-2, 4)$$

$$C) (-2, \infty)$$

$$D) (-\infty, -2)$$

Answer: C

$$321) \frac{x+10}{x+1} < 5$$

$$A) \left[-1, \frac{5}{4}\right)$$

$$B) \left(-\infty, \frac{5}{4}\right) \cup (1, \infty)$$

$$C) (-\infty, -1) \cup (1, \infty)$$

$$D) (-\infty, -1) \cup \left[\frac{5}{4}, \infty\right)$$

Answer: D

$$322) x + \frac{24}{x} < 10$$

$$A) (-\infty, 0) \cup (6, \infty)$$

$$B) (0, 4) \cup (6, \infty)$$

$$C) (0, 4) \cup (4, 6)$$

$$D) (-\infty, 0) \cup (4, 6)$$

Answer: D

$$323) \frac{(x-2)^2}{x^2-25} > 0$$

$$A) (-\infty, -5) \cup (2, 5)$$

$$B) (-5, 2) \cup (2, 5)$$

$$C) (-5, 2) \cup (5, \infty)$$

$$D) (-\infty, -5) \cup (5, \infty)$$

Answer: D

$$324) \frac{3x}{6-x} < x$$

$$A) (-\infty, 3) \cup (6, \infty)$$

$$B) (3, 6)$$

$$C) (0, 3) \cup (6, \infty)$$

$$D) (6, \infty)$$

Answer: C

$$325) \frac{12x}{4-x} \geq 6x$$

$$A) [0, 2] \cup [4, \infty)$$

$$B) (-\infty, 0] \cup [2, 4)$$

$$C) (-\infty, 2] \cup [4, \infty)$$

$$D) [4, \infty)$$

Answer: B

$$326) \frac{12}{x-5} > \frac{10}{x+1}$$

$$A) (-31, -1) \cup (-1, 5)$$

$$B) (-31, -1) \cup (5, \infty)$$

$$C) (-\infty, -31) \cup (5, \infty)$$

$$D) (-\infty, -31) \cup (-1, 5)$$

Answer: B

### Solve the problem.

327) The profit made when  $t$  units are sold,  $t > 0$ , is given by  $P = t^2 - 28t + 180$ . Determine the number of units to be sold in order for  $P = 0$  (the break-even point).

$$A) t = 18 \text{ or } t = 10$$

$$B) t = -18 \text{ or } t = -10$$

$$C) t > 18$$

$$D) t = 28$$

Answer: A

328) The profit made when  $t$  units are sold,  $t > 0$ , is given by  $P = t^2 - 32t + 247$ . Determine the number of units to be sold in order for  $P > 0$  (a profit is made).

$$A) t > 19 \text{ or } t < 13$$

$$B) 19 < t < 13$$

$$C) t = 32$$

$$D) t = 19 \text{ or } t = 13$$

Answer: A

- 329) The profit made when  $t$  units are sold,  $t > 0$ , is given by  $P = t^2 - 33t + 260$ . Determine the number of units to be sold in order for  $P < 0$  (a loss is taken).

A)  $t > 0$                       B)  $t < 13$  or  $t > 20$                       C)  $13 < t < 20$                       D)  $t = 13$  or  $t = 20$

Answer: C

- 330) The cost of producing  $t$  units is  $C = 4t^2 + 5t$ , and the revenue generated from sales is  $R = 5t^2 + t$ . Determine the number of units to be sold in order to generate a profit.

A)  $t > 6$                       B)  $t > 5$                       C)  $t > 4$                       D)  $t > 0$

Answer: C

- 331) The total profit function  $P(x)$  for a company producing  $x$  thousand units is given by  $P(x) = -2x^2 + 28x - 66$ . Find the values of  $x$  for which the company makes a profit. [Hint: The company makes a profit when  $P(x) > 0$ .]

A)  $x$  is less than 11 thousand units  
B)  $x$  is greater than 3 thousand units  
C)  $x$  is less than 3 thousand units or greater than 11 thousand units  
D)  $x$  is between 3 thousand units and 11 thousand units

Answer: D

- 332) The average cost per unit,  $y$ , of producing  $x$  units of a product is modeled by  $y = \frac{300,000 + 0.45x}{x}$ . Describe the company's production level so that the average cost of producing each unit does not exceed \$1.95.

A) At least 300,000 units                      B) Not more than 300,000 units  
C) Not more than 200,000 units                      D) At least 200,000 units

Answer: D

- 333) A rectangular enclosure must have an area of at least 600  $\text{yd}^2$ . If 100 yd of fencing is to be used, and the width cannot exceed the length, within what limits must the width of the enclosure lie?

A)  $20 \leq w \leq 30$                       B)  $20 \leq w \leq 25$                       C)  $25 \leq w \leq 30$                       D)  $0 \leq w \leq 20$

Answer: B

- 334) The perimeter of a rectangle is 48 feet. Describe the possible lengths of a side if the area of the rectangle is to be greater than 119 square feet.

A) The length of the rectangle must be greater than 17 ft or less than 7 ft  
B) The length of the rectangle must be greater than 17 ft  
C) The length of the rectangle must lie between 1 and 119 ft  
D) The length of the rectangle must lie between 7 and 17 ft

Answer: D

- 335) If a rocket is propelled upward from ground level, its height in meters after  $t$  seconds is given by  $h = -9.8t^2 + 49t$ . During what interval of time will the rocket be higher than 58.8 m?

A)  $4 < t < 5$                       B)  $3 < t < 4$                       C)  $2 < t < 3$                       D)  $0 < t < 2$

Answer: C

- 336) A flare fired from the bottom of a gorge is visible only when the flare is above the rim. If it is fired with an initial velocity of 80 ft/sec, and the gorge is 96 ft deep, during what interval can the flare be seen?

( $h = -16t^2 + v_0t + h_0$ .)

A)  $0 < t < 2$                       B)  $6 < t < 7$                       C)  $4 < t < 5$                       D)  $2 < t < 3$

Answer: D

337) An arrow is fired straight up from the ground with an initial velocity of 224 feet per second. Its height,  $s(t)$ , in feet at any time  $t$  is given by the function  $s(t) = -16t^2 + 224t$ . Find the interval of time for which the height of the arrow is greater than 460 feet.

A) between  $\frac{5}{2}$  and  $\frac{23}{2}$  sec

B) before  $\frac{23}{2}$  sec

C) before  $\frac{5}{2}$  sec or after  $\frac{23}{2}$  sec

D) after  $\frac{5}{2}$  sec

Answer: A

338) A ball is thrown vertically upward with an initial velocity of 192 feet per second. The distance in feet of the ball from the ground after  $t$  seconds is  $s = 192t - 16t^2$ . For what interval of time is the ball more than 512 above the ground?

A) between 5.5 and 6.5 seconds

B) between 4 and 8 seconds

C) between 10 and 14 seconds

D) between 3.5 and 8.5 seconds

Answer: B

339) A ball is thrown vertically upward with an initial velocity of 160 feet per second. The distance in feet of the ball from the ground after  $t$  seconds is  $s = 160t - 16t^2$ . For what intervals of time is the ball less than 336 above the ground (after it is tossed until it returns to the ground)?

A) between 0 and 3 seconds and between 7 and 10 seconds

B) between 0 and 2.5 seconds and between 7.5 and 10 seconds

C) between 0 and 4.5 seconds and between 5.5 and 10 seconds

D) between 3 and 7 seconds

Answer: A

340) You drive 115 miles along a scenic highway and then take a 26-mile bike ride. Your driving rate is 5 times your cycling rate. Suppose you have no more than a total of 4 hours for driving and cycling. Let  $x$  represent your cycling rate in miles per hour. Use a rational inequality to determine the possible values of  $x$ .

A)  $x \leq 12.3$  mph

B)  $x \geq 30.1$  mph

C)  $x \leq 48.8$  mph

D)  $x \geq 12.3$  mph

Answer: D

341) At a single ticket booth, customers arrive randomly at a rate of  $x$  per hour. The average line length is given by

$$f(x) = \frac{x^2}{400 - 20x},$$

where  $0 \leq x < 20$ . To keep the wait in line reasonable, it is required that the average line length should not exceed 5 customers. Determine the range of rates at which customers can arrive before a second attendant is needed. Express your answer in interval form.

A)  $[0, 18]$

B)  $[0, 17]$

C)  $[0, 19]$

D)  $[0, 16]$

Answer: B

342) If a parking ramp attendant can wait on 4 vehicles per minute and vehicles are leaving the ramp at  $x$  vehicles per minute, then the average wait (in minutes) for a car trying to exit is modeled by the function

$$f(x) = \frac{1}{4 - x}.$$

Solve the inequality  $3 \leq \frac{1}{4 - x} \leq 8$  to determine the range of rates  $x$  that would result in average wait times

between 3 and 8 minutes. Express your answer in interval form, rounding numbers to the nearest tenth.

A)  $(3.7, 3.9)$

B)  $(0, 3.7) \cup (3.9, \infty)$

C)  $(0.6, 1.7)$

D)  $(3.6, 4.0)$

Answer: A



Use Descartes' Rule of Signs to determine the possible number of positive real zeros and the possible number of negative real zeros for the function.

343)  $f(x) = 8x^3 - 2x^2 + 3x + 6$

- A) 0 or 2 positive; 1 negative  
C) 0 or 1 positive; 0 or 1 negative

- B) 0 positive; 1 or 2 negative  
D) 0 or 1 positive; 2 negative

Answer: A

344)  $f(x) = 4x^8 + 3x^6 + 2x^4 + 9x^2 + 7$

- A) 0 positive; 4 negative  
C) 4 positive; 4 negative

- B) 4 positive; 0 negative  
D) 0 positive; 0 negative

Answer: D

345)  $f(x) = -7x^4 + 2x^3 - 9x^2 + 2x - 5$

- A) 0, 2, or 4 positive; 0 negative  
C) 0 or 2 positive; 0 or 2 negative

- B) 0, 2, or 4 positive; 0, 2, or 4 negative  
D) 0 or 2 positive; 0, 2, or 4 negative

Answer: A

346)  $f(x) = 4x^5 - 2x^4 + 8x^3 - 7$

- A) 1 or 3 positive; 1 or 3 negative  
C) 1 positive; 1 or 3 negative

- B) 0, 2, or 4 positive; 0 negative  
D) 1 or 3 positive; 0 negative

Answer: D

347)  $f(x) = -7x^4 - 8x^3 - 2x^2 - 2x + 3$

- A) 1 positive; 2 negative  
C) 1 positive; 1 negative

- B) 1 positive; 1 or 3 negative  
D) 0 or 2 positive; 0 or 2 negative

Answer: B

348)  $f(x) = 7x^6 - 4x^4 - 5x^3 + 7x^2 - 3x$

- A) 1 or 3 positive; 0 or 2 negative  
C) 0 or 2 positive; 0 negative

- B) 1 or 3 positive; 2 negative  
D) 0 or 2 positive; 1 or 3 negative

Answer: A

Determine the upper and lower bounds on the zeros of the given function.

349)  $f(x) = 6x^3 - 7x^2 + 7x + 9$

- A) upper bound: 2; lower bound: -2  
C) upper bound: 1; lower bound: -1

- B) upper bound: 2; lower bound: -3  
D) upper bound: 2; lower bound: -1

Answer: D

350)  $F(x) = 2x^3 - 3x^2 - 4x + 4$

- A) upper bound: 3; lower bound: -3  
C) upper bound: 3; lower bound: -1

- B) upper bound: 3; lower bound: -2  
D) upper bound: 2; lower bound: -3

Answer: B

351)  $f(x) = 3x^5 + 6x^3 - 8x^2 + 4$

- A) upper bound: 1; lower bound: -4  
C) upper bound: 1; lower bound: -1

- B) upper bound: 4; lower bound: -1  
D) upper bound: 4; lower bound: -4

Answer: C

352)  $g(x) = 5x^4 - 9x^2 + 3$

A) upper bound: 1; lower bound: -2

C) upper bound: 2; lower bound: -1

Answer: B

B) upper bound: 2; lower bound: -2

D) upper bound: 1; lower bound: -1

353)  $F(x) = 3x^4 - 8x^3 - 8x - 9$

A) upper bound: 4; lower bound: -1

C) upper bound: 2; lower bound: -2

Answer: A

B) upper bound: 1; lower bound: -2

D) upper bound: 1; lower bound: -1

354)  $G(x) = 4x^3 - 8x - 1$

A) upper bound: 4; lower bound: -2

C) upper bound: 1; lower bound: -1

Answer: B

B) upper bound: 2; lower bound: -2

D) upper bound: 3; lower bound: -2

355)  $h(x) = 8x^3 + 9x + 3$

A) upper bound: 2; lower bound: -2

C) upper bound: 1; lower bound: -2

Answer: B

B) upper bound: 1; lower bound: -1

D) upper bound: 2; lower bound: -1

**Find all solutions of the equation in the complex number system.**

356)  $x^2 + 16 = 0$

A) {4}

B) {4, -4}

C) {8}

D) {4i, -4i}

Answer: D

357)  $(x + 1)^2 = -7$

A)  $\{-1 - \sqrt{7}\}$

C) {6, 8}

Answer: B

B)  $\{-1 + i\sqrt{7}, -1 - i\sqrt{7}\}$

D)  $\{-1 + \sqrt{7}, -1 - \sqrt{7}\}$

358)  $x^4 - 81 = 0$

A) {3i, -3i}

B) {3, 3i}

C) {-3, 3, 3i, -3i}

D) {-3, 3}

Answer: C

359)  $x^2 - 6x + 9 = -4$

A) {3 + 2i}

B)  $\emptyset$

C) {3 + 2i, 3 - 2i}

D) {3 - 2i}

Answer: C

360)  $25x^2 + 16 = 0$

A)  $\left\{\frac{4}{5}i\right\}$

B)  $\left\{\frac{4}{5}i, -\frac{4}{5}i\right\}$

C)  $\left\{\frac{4}{5}, -\frac{4}{5}\right\}$

D)  $\left\{-\frac{4}{5}i\right\}$

Answer: B

361)  $x^3 + 1 = 0$

A)  $\{-1i, \frac{1}{2} + \frac{1}{2}\sqrt{3}i, \frac{1}{2} - \frac{1}{2}\sqrt{3}i\}$

B)  $\{-1\}$

C)  $\{-1, \frac{1}{2} + \frac{1}{2}\sqrt{3}, \frac{1}{2} - \frac{1}{2}\sqrt{3}\}$

D)  $\{-1, \frac{1}{2} + \frac{1}{2}\sqrt{3}i, \frac{1}{2} - \frac{1}{2}\sqrt{3}i\}$

Answer: D

362)  $(x + 7)(x - 3i)(x + 3i) = 0$

A)  $\{-7, 3i, -3i\}$

B)  $\{-7\}$

C)  $\{-7, 3, -3\}$

D)  $\{-7i, 3i, -3i\}$

Answer: A

**Find the remaining zeros of a polynomial with real coefficients and having the specified degree and zeros.**

363) Degree 3; zeros: 3, 5 - i

A) -5 + i

B) 5 + i

C) -3

D) no other zeros

Answer: B

364) Degree 4; zeros: i, 1 + i

A) -1 + i, 1 - i

B) -i, -1 + i

C) 1 - i

D) -i, 1 - i

Answer: D

365) Degree 4; zeros: 8 - 5i, 5i

A) -8 + 5i, -5i

B) -8 - 5i, -5i

C) 8 + 5i, 5 - i

D) 8 + 5i, -5i

Answer: D

366) Degree 3; zeros: -3, 3 - 5i

A) -3 + 5i

B) 3, 3 + 5i

C) 3, -3 + 5i

D) 3 + 5i

Answer: D

367) Degree 5; zeros: 3, 8 + 5i, -3i

A) -8 + 5i, 3i

B) 8 - 5i, 3i

C) -8 - 5i, 3i

D) -3, 8 - 5i, 3i

Answer: B

368) Degree 5; zeros: -1, i, 2i

A) 1, -2i

B) 1, -i, -2i

C) 1, -i

D) -i, -2i

Answer: D

369) Degree 6; zeros: 3, 3 + i, -4 - i, 0

A) -3 - i, 4 + i

B) -3 + i, 4 - i

C) 3 - i, -4 + i

D) -3, 3 - i, -4 + i

Answer: C

370) Degree 6; zeros: -6, 7, 6 - 5i, -7 + i

A) 6 + 5i, -7 - i

B) 6, 6 + 5i

C) -6 + 5i, 7 - i

D) 6, 6 + 5i, -7 - i

Answer: A

**Find the polynomial P(x) with real coefficients having the specific degree, leading coefficient, and zeros.**

371) degree: 3, leading coefficient: -2, zeros: 3, 5 + 4i

A)  $P(x) = x^3 - 13x^2 + 71x - 123$

B)  $P(x) = -2x^3 - 26x^2 - 142x - 246$

C)  $P(x) = 2x^3 + 26x^2 + 142x + 246$

D)  $P(x) = -2x^3 + 26x^2 - 142x + 246$

Answer: D

372) degree: 6, leading coefficient: 4, zeros: 4, 0 (multiplicity 3), 5 - 2i

A)  $P(x) = 4x^6 - 56x^5 + 276x^4 - 464x^3$

B)  $P(x) = 4x^6 + 56x^5 + 276x^4 - 464x^3$

C)  $P(x) = 4x^6 + 56x^5 - 276x^4 + 464x^3$

D)  $P(x) = x^6 - 14x^5 + 69x^4 - 116x^3$

Answer: A

**Use the given zero to find all zeros of the function.**

373)  $f(x) = x^4 - 32x^2 - 144$ ; zero: -2i

A) 2i, 6, -6

B) 2i, 12, -12

C) 2i, 12i, -12i

D) 2i, 6i, -6i

Answer: A

374)  $f(x) = x^3 + 5x^2 - 12x + 14$ ; zero: 1 + i

A) 1 - i, -7

B) -7, 7

C) 1 - i, 7

D) 1 - i, 7i

Answer: A

375)  $f(x) = x^3 - 2x^2 - 11x + 52$ ; zero: -4

A) 3 + 2i, 3 - 2i

B) 1 + 2i, 1 - 2i

C) 6 + 4i, 6 - 4i

D)  $1 + 2i\sqrt{13}$ ,  $1 - 2i\sqrt{13}$

Answer: A

376)  $f(x) = x^3 + 6x^2 + 21x + 26$ ; zero: -2 + 3i

A) -2 - 3i, 2

B) 3 - 2i, 2

C) 3 - 2i, -2

D) -2 - 3i, -2

Answer: D

377)  $f(x) = 3x^4 - 20x^3 + 75x^2 - 120x + 52$ ; zero: 2 + 3i

A) 3 - 2i, 2,  $-\frac{2}{3}$

B) 2 - 3i, 2,  $\frac{2}{3}$

C) 3 - 2i, -2,  $-\frac{2}{3}$

D) 2 - 3i, -2,  $\frac{2}{3}$

Answer: B

378)  $f(x) = x^5 - 10x^4 + 42x^3 - 124x^2 + 297x - 306$ ; zero: 3i

A) 2, -3i, 4 - i, 4 + i

B) 2, -3i, -4 - i, -4 + i

C) -2, -3i, -4 - i, -4 + i

D) -2, -3i, 4 - i, 4 + i

Answer: C

**Find all the zeros of the polynomial function.**

379)  $P(x) = x^3 - 9x^2 + x - 9$

A) 9, -i, i

B) -9, 9, i

C) -1, 1, 9

D) -9, -i, i

Answer: A

380)  $P(x) = 3x^3 - 13x^2 + 43x - 13$

A)  $\frac{1}{3}$ , 2 + 3i

B) 2 + 3i, 2 - 2i

C)  $\frac{1}{3}$ , 2 + 3i, 2 - 2i

D)  $\frac{1}{3}$

Answer: C

381)  $P(x) = 16x^3 - 24x^2 + 10x - 2$

A)  $\frac{1}{4} + \frac{1}{4}i$ ,  $\frac{1}{4} - \frac{1}{4}i$

B)  $1, \frac{1}{4} + \frac{1}{4}i$

C)  $1, \frac{1}{4} + \frac{1}{4}i, \frac{1}{4} - \frac{1}{4}i$

D) 1

Answer: C

382)  $P(x) = 3x^4 - 10x^3 + 20x^2 - 40x + 32$

A)  $-\frac{4}{3}, -2, -2i, 2i$

B)  $\frac{4}{3}, 2, -2i, 2i$

C)  $\frac{4}{3}, 2, -i, i$

D)  $\frac{2}{3}, 2, -4i, 4i$

Answer: B

383)  $P(x) = x^3 + 8x^2 + 30x + 36$

A)  $-2, -3 + 3i, -3 - 3i$

B)  $2, -3 + \sqrt{5}, -6 - \sqrt{5}$

C)  $-2, 3 + 3i, 3 - 3i$

D)  $-2, 3 + \sqrt{5}, 3 - \sqrt{5}$

Answer: A

384)  $P(x) = x^4 - 5x^3 + 21x^2 + 19x - 348$

A)  $3, -4, 2 + \sqrt{5}, 2 - \sqrt{5}$

B)  $-3, 4, 2 + 6i, 2 - 6i$

C)  $3, -4, 2 + 5i, 2 - 5i$

D)  $-3, 4, 2 + 5i, 2 - 5i$

Answer: D

385)  $P(x) = 3x^4 + 22x^3 + 64x^2 + 58x + 13$

A)  $1, +\frac{1}{3}, -2 + 3i, -2 - 3i$

B)  $1, -\frac{1}{3}, -3 + 2i, -3 - 2i$

C)  $-1, +\frac{1}{3}, -2 + 3i, -2 - 3i$

D)  $-1, -\frac{1}{3}, -3 + 2i, -3 - 2i$

Answer: D

Find an equation of a polynomial function of least degree having the given complex zeros, intercepts, and graph.

386)  $f(x)$  has complex zero  $7i$

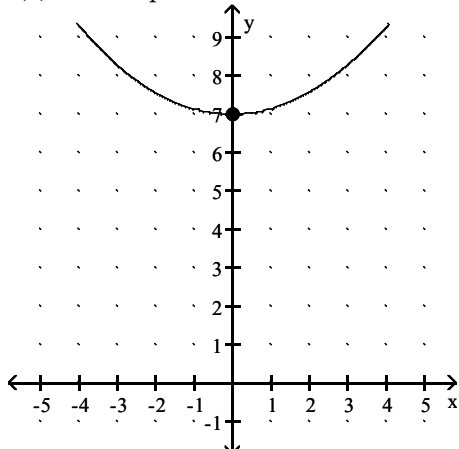

A)  $f(x) = \frac{1}{7}(x^2 - 49)$

B)  $f(x) = \frac{1}{7}(x^2 + 49)$

C)  $f(x) = \frac{1}{49}(x^2 + 49)$

D)  $f(x) = \frac{1}{7}(x^2 + 7)$

Answer: B

387)  $f(x)$  has complex zero  $i$

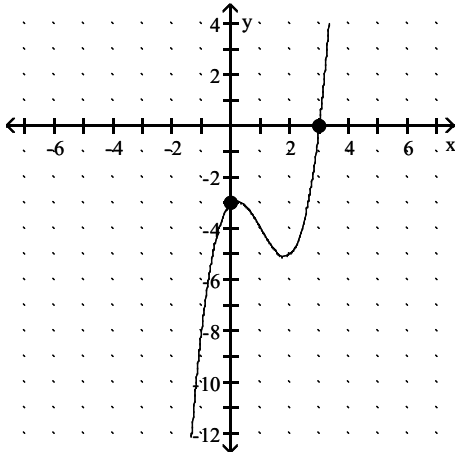

A)  $f(x) = (x + 3)(x^2 + 1)$

C)  $f(x) = (x + 3)(x - 3)$

B)  $f(x) = (x - 3)(x^2 + 1)$

D)  $f(x) = (x - 3)(x + 1)(x - 1)$

Answer: B

388)  $f(x)$  has complex zeros  $-i$  and  $-2i$

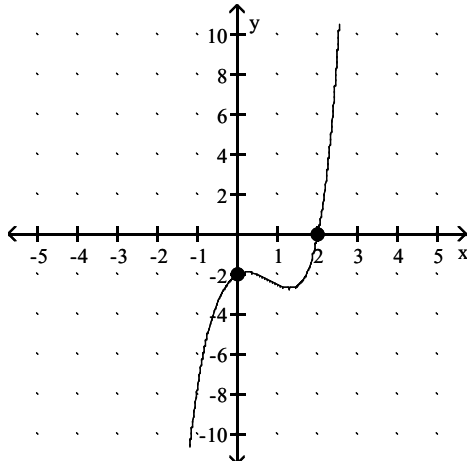

A)  $f(x) = \frac{1}{4}(x^2 + 1)(x^2 + 4)(x - 2)$

C)  $f(x) = \frac{1}{4}(x^2 + 1)(x^2 + 4)(x + 2)$

B)  $f(x) = \frac{1}{2}(x - 1)(x + 1)(x - 4)(x + 4)(x - 2)$

D)  $f(x) = \frac{1}{2}(x^2 + 1)(x^2 + 4)(x - 2)$

Answer: A

**Write the given statement as an equation.**

389) The perimeter  $P$  of an equilateral triangle varies directly as the side  $s$ .

A)  $P = \frac{s}{3}$

B)  $P = ks$

C)  $P = 3s$

D)  $P = 3s^2$

Answer: B

390) The area of an equilateral triangle varies directly as the square of the side  $s$ .

A)  $A = ks^2$

B)  $A = k^2s$

C)  $A = \frac{s^2}{k}$

D)  $A = \frac{k}{s^2}$

Answer: A

391) The height  $h$  of a triangle with a fixed area varies inversely as the base  $b$ .

- A)  $b = kh$                       B)  $h = \frac{b}{k}$                       C)  $h = kb$                       D)  $h = \frac{k}{b}$

Answer: D

392) John kept track of the time it took him to drive to college from his home and the speed at which he drove. He found that the time  $t$  varies inversely as the speed  $r$ .

- A)  $r = kt$                       B)  $t = kr$                       C)  $t = \frac{k}{r}$                       D)  $t = \frac{r}{k}$

Answer: C

393) The height  $h$  of a cone with a fixed volume varies inversely as the square of its radius  $r$ .

- A)  $h = \frac{r^2}{k}$                       B)  $h = kr^2$                       C)  $h = \frac{k}{r^2}$                       D)  $r^2 = kh$

Answer: C

394) The surface area of a sphere  $S$  varies directly as the square of its radius  $r$ .

- A)  $S = \frac{r^2}{k}$                       B)  $S = k^2r$                       C)  $S = kr^2$                       D)  $S = \frac{k}{r^2}$

Answer: C

395) The altitude  $h$  of an equilateral triangle varies directly as one side  $s$ .

- A)  $h = \frac{k}{s}$                       B)  $h = ks^2$                       C)  $h = ks$                       D)  $h = \frac{s}{k}$

Answer: C

396) The cost  $c$  of a turkey varies directly as its weight  $w$ .

- A)  $c = \frac{w}{k}$                       B)  $c = kw$                       C)  $c = kw^2$                       D)  $c = \frac{k}{w}$

Answer: B

397) The area of a triangle varies jointly as the base and the height.

- A)  $A = bh$                       B)  $A = \frac{kb}{h}$                       C)  $A = k(b + h)$                       D)  $A = kbh$

Answer: D

398) The force of attraction between an object of fixed mass and a second object of mass  $m$  varies directly as  $m$  and inversely as the square of the distance  $d$  between the two objects.

- A)  $F = kmd^2$                       B)  $F = \frac{km}{d}$                       C)  $F = \frac{k}{md^2}$                       D)  $F = \frac{km}{d^2}$

Answer: D

**Solve for the requested variable.**

399)  $m$  varies directly as  $p$ , and  $m = 27$  when  $p = 3$ . Find  $m$  when  $p$  is 7.

- A)  $m = 9$                       B)  $m = 49$                       C)  $m = 81$                       D)  $m = 63$

Answer: D

400)  $s$  varies directly as the square of  $t$ , and  $s = 245$  when  $t = 7$ . Find  $s$  when  $t$  is 6.

A)  $s = 42$

B)  $s = 210$

C)  $s = 35$

D)  $s = 180$

Answer: D

401)  $y$  varies directly as  $z$ , and  $y = 143$  when  $z = 13$ . Find  $y$  when  $z$  is 19.

A)  $y = 361$

B)  $y = 121$

C)  $y = 209$

D)  $y = 169$

Answer: C

402)  $y$  varies directly as  $x$ , and  $y = 5$  when  $x = 4$ . Find  $y$  when  $x = 16$ .

A)  $y = 20$

B)  $y = \frac{4}{5}$

C)  $y = \frac{64}{5}$

D)  $y = \frac{5}{4}$

Answer: A

403)  $c$  varies jointly as  $a$  and  $b$ . Find  $c$  when  $a = 15$ ,  $b = 7$ , and  $k = 3$ .

A)  $c = 35$

B)  $c = 105$

C)  $c = 315$

D)  $c = \frac{7}{5}$

Answer: C

404)  $f$  varies jointly as  $h$  and the square of  $q$ , and  $f = 96$  when  $q = 4$  and  $h = 3$ . Find  $k$ .

A)  $k = 3$

B)  $k = 2$

C)  $k = 4$

D)  $k = 96$

Answer: B

405)  $y$  varies inversely as  $x$ , and  $y = \frac{9}{5}$  when  $x = \frac{1}{3}$ . Find  $y$  when  $x = \frac{1}{5}$ .

A)  $y = 3$

B)  $y = \frac{3}{25}$

C)  $y = \frac{3}{5}$

D)  $y = \frac{27}{25}$

Answer: A

406)  $y$  varies directly as  $x$  and inversely as the square root of  $w$ , and  $y = 42$  when  $x = 7$  and  $w = 20$ . Find  $y$  when  $x = 4$  and  $w = 45$ .

A)  $y = 48\sqrt{5}$

B)  $y = 16$

C)  $y = 32$

D)  $y = 12\sqrt{5}$

Answer: B

407)  $y$  varies directly as the square of  $x$  and inversely as  $m$ , and  $y = 6$  when  $x = 2$  and  $m = 8$ . Find  $y$  when  $x = 10$  and  $m = 5$ .

A)  $y = 0.64$

B)  $y = 240$

C)  $y = 48$

D)  $y = 1.92$

Answer: B

408)  $y$  varies directly as  $x$  and inversely as the square of  $z$ , and  $y = 9$  when  $x = 64$  and  $z = 8$ . Find  $y$  when  $x = 32$  and  $z = 5$ .

A)  $y = 1.76$

B)  $y = 57.6$

C)  $y = 7.2$

D)  $y = 11.52$

Answer: D

409)  $y$  varies jointly as  $a$  and  $b$  and inversely as the square root of  $c$ , and  $y = 105$  when  $a = 5$ ,  $b = 7$ , and  $c = 9$ . Find  $y$  when  $a = 9$ ,  $b = 6$ , and  $c = 25$ .

A)  $y = 97.2$

B)  $y = 2430$

C)  $y = 10.8$

D)  $y = 19.44$

Answer: A



Solve for the requested variable without determining the constant of variation,  $k$ . Use the fact that if  $x_1 = ky_1$  and

$x_2 = ky_2$ , then  $\frac{x_1}{y_1} = k = \frac{x_2}{y_2}$  so that  $\frac{x_1}{y_1} = \frac{x_2}{y_2}$ .

410) Assuming that  $y$  varies directly as the cube of  $x$ , and  $y = 6$  when  $x = 21$ , find  $y$  when  $x = 35$ .

- A)  $y = \frac{18}{5}$                       B)  $y = \frac{250}{9}$                       C)  $y = \frac{162}{125}$                       D)  $y = 10$

Answer: B

411) Assuming that  $y$  varies directly as the square root of  $x$ , and  $y = 8$  when  $x = 25$ , find  $y$  when  $x = 1$ .

- A)  $y = 40$                       B)  $y = 200$                       C)  $y = \frac{8}{5}$                       D)  $y = \frac{8}{25}$

Answer: C

**Solve the problem.**

412) The distance  $D$  that a spring is stretched by a hanging object varies directly as the weight  $W$  of the object. If a 20-kg object stretches a spring 30 cm, how far will a 6-kg weight stretch the spring?

- A) 9 cm                      B) 1.5 cm                      C) 56 cm                      D) 4 cm

Answer: A

413) The number  $G$  of gears a machine can make varies directly as the time  $T$  it operates. If it can make 5417 gears in 2 hours, how many gears can it make in 5 hours?

- A) 5424 gears                      B) 13,542.5 gears                      C) 0.0018 gears                      D) 2708.5 gears

Answer: B

414) The volume  $V$  of a gas at constant temperature varies inversely as the pressure  $P$  on it. The volume of a gas is  $220 \text{ cm}^3$  under a pressure of  $24 \text{ kg/cm}^2$ . What will be its volume under a pressure of  $40 \text{ kg/cm}^2$ ? [Assume that the temperature remains constant].

- A)  $132 \text{ cm}^3$                       B)  $330 \text{ cm}^3$                       C)  $367 \text{ cm}^3$                       D)  $119 \text{ cm}^3$

Answer: A

415) The speed of a vehicle is inversely proportional to the time it takes to travel a fixed distance. If a vehicle travels a fixed distance at 45 miles per hour in 60 minutes, how fast must it travel to cover the same distance in 25 minutes?

- A)  $\frac{75}{4}$  mph                      B) 108 mph                      C)  $\frac{4}{75}$  mph                      D)  $\frac{100}{3}$  mph

Answer: B

416) The distance to the horizon varies directly as the square root of the height above ground level of the observer. If a person can see 6 miles from a height of 25 feet, how far can a person see from a height of 100 feet?

- A) 13.2 mi                      B) 12.3 mi                      C) 11 mi                      D) 12 mi

Answer: D

417) The area of a circle varies directly as the square of the radius of the circle. If a circle with a radius of 5 inches has an area of  $78.5 \text{ square inches}$ , what is the area of a circle with a radius of 8 inches?

- A)  $50.24 \text{ in.}^2$                       B)  $25.12 \text{ in.}^2$                       C)  $200.96 \text{ in.}^2$                       D)  $203.36 \text{ in.}^2$

Answer: C

418) Wind resistance or atmospheric drag tends to slow down moving objects. Atmospheric drag varies jointly as an object's surface area  $A$  and velocity  $v$ . If a car traveling at a speed of 60 mph with a surface area of  $34 \text{ ft}^2$  experiences a drag of 326.4 N (Newtons), how fast must a car with  $48 \text{ ft}^2$  of surface area travel in order to experience a drag force of 537.6 N?

- A) 72 mph                      B) 70 mph                      C) 75 mph                      D) 67 mph

Answer: B

419) The cost of stainless steel tubing varies jointly as the length and the diameter of the tubing. If a 5 foot length with diameter 2 inches costs \$48.00, how much will a 15 foot length with diameter 3 inches cost?

- A) \$213.60                      B) \$216.00                      C) \$221.30                      D) \$221.57

Answer: B

420) The resistance of a wire varies directly as the length of the wire and inversely as the square of the diameter of the wire. A 20 foot length of wire with a diameter of 0.1 inch has a resistance of 3 ohms. What would the resistance be for a 32 foot length, with diameter 0.01 inch, of the same kind of wire?

- A) 492 ohms                      B) 480 ohms                      C) 473 ohms                      D) 477.5 ohms

Answer: B

421) The force needed to keep a car from skidding on a curve varies jointly as the weight of the car and the square of the car's speed, and inversely as the radius of the curve. If a force of 3600 pounds is needed to keep an 1800 pound car traveling at 20 mph from skidding on a curve of radius 600 feet, what force would be required to keep the same car from skidding on a curve of radius 570 feet at 60 mph? Round your answer to the nearest pound of force?

- A) 34,675 lb                      B) 34,105 lb                      C) 33,973 lb                      D) 34,137 lb

Answer: B