

John Wiley & Sons, Inc.
Publishers Since 1807

READ IMPORTANT LICENSE INFORMATION

Dear Professor or Other Authorized User:

John Wiley & Sons, Inc. (“Wiley”) has produced the attached solutions manual or other copyrighted material (the “Supplement”) solely for use by professors and other authorized users in the manner provided below. Wiley has established these use limitations in response to concerns raised by professors and other authorized users regarding the pedagogical problems stemming from unlimited distribution of Supplements.

If the attached Supplement was delivered to you by Wiley or its representatives or if you are a professor of a course that has adopted the textbook to which the Supplement relates (the “Course”), then you are an authorized user of the Supplement. As an authorized user, Wiley grants you a non-transferable license to use the Supplement subject to the following conditions. The Supplement is for your personal use only, except that you may post the Supplement (or portions thereof) on a password protected website or otherwise provide the Supplement (or portions thereof) to students of the Course so long as such students are advised that they may not copy or distribute the Supplement to any third party. The Supplement may only be used in connection with Courses for which the related textbook has been adopted. You should take reasonable steps to protect the Supplement from unauthorized use, reproduction, or distribution. Your use of the Supplement indicates your acceptance of the conditions set forth in this Agreement. If you do not accept these conditions, you must return the Supplement unused within 30 days of receipt.

All rights (including without limitation, copyrights, patents and trade secrets) in the Supplement are and will remain the sole and exclusive property of Wiley and/or its licensors. The Supplement is furnished by Wiley on an “as is” basis without any warranties, express or implied. This Agreement will be governed by and construed pursuant to the laws of the State of New York, without regard to such State’s conflict of law rules.

We hope that you find the Supplement useful.

Sincerely,

JOHN WILEY & SONS, INC.

Excerpts from this work may be reproduced by instructors for distribution on a not-for-profit basis for testing or instructional purposes only to students enrolled in courses for which the textbook, Fundamentals of Machine Component Design by Robert C. Juvinall and Kurt M. Marshek has been adopted. Any other reproduction or translation of this work beyond that permitted by Sections 107 or 108 of the 1976 United States Copyright Act without the permission of the copyright owner is unlawful.

SOLUTION (2.1D)

Known: Definitions are needed for the terms: free-body diagram, equilibrium analysis, internal loads, external loads, and three-force members.

Find: Write definitions of above terms.

Analysis:

1. A free-body diagram is a drawing or a sketch of a body (or part of a body) that shows all the forces from the surroundings acting on that body. The forces could be caused by gravitational attraction, centrifugal acceleration, magnetic repulsion or attraction, or another body.
 2. An equilibrium analysis is an analytical method that employs the basic equations of equilibrium to determine unknown loads (forces and/or moments).
 3. An internal load is a load internal to the body and not from the surroundings.
 4. An external load is a load from the surroundings that acts on a member.
 5. A three-force member is a body that has three forces from the surroundings acting on the body. If the body is in static equilibrium the forces (or projection of the forces) all pass through a common point and the sum of the three vector forces is zero.
-

SOLUTION (2.2)

Known: The Iron Arms forearm grips exercises the forearm by resisting the rotation of the handle grips – see textbook FIGURE P2.2. The Iron Arms consists of a handle which rotates inside of the housing that compresses a helical spring. The dimensions of the Iron Arms forearm grip are known.

Find: Draw a free body diagram of each spring, each handle, the housing (rings) and the Iron Arms assembly.

Assumptions:

1. No gravitational forces, frictional forces or handle torque act on the components.
2. The unit is at static equilibrium at the rotated position.

Schematic and Given Data: See FIGURE P2.2 in the textbook.

Analysis:

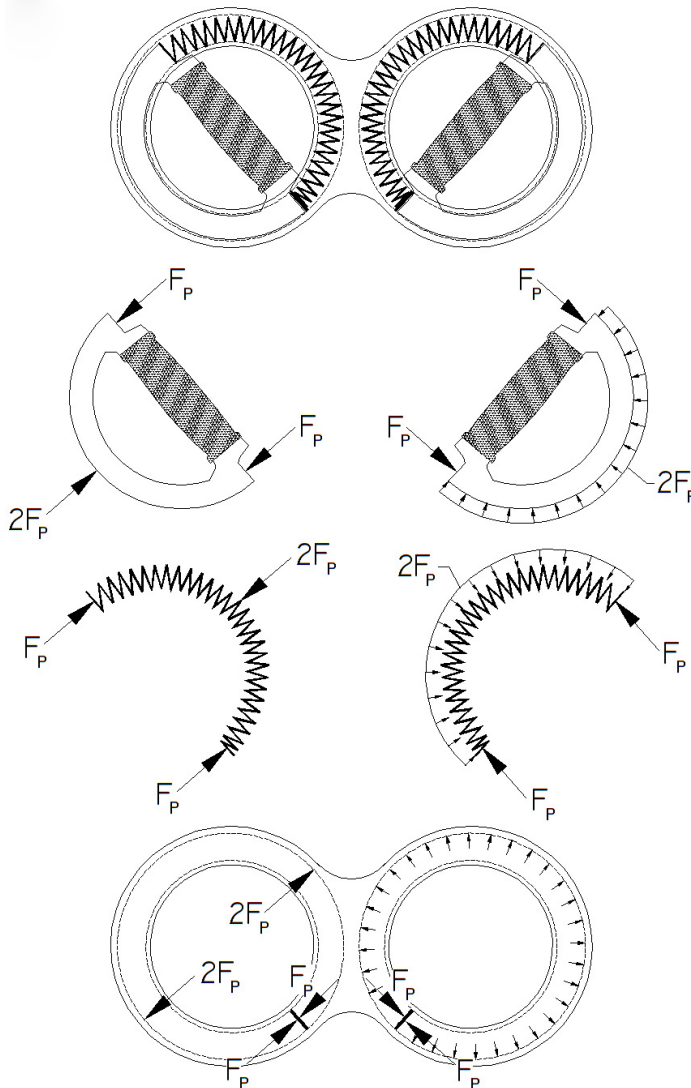

SOLUTION (2.3)

Known: The Iron Arms forearm grips exercises the forearm by resisting the rotation of the handle grips – see textbook FIGURE P2.2. The Iron Arms consists of a handle which rotates inside of the housing that compresses a helical spring. The dimensions of the Iron Arms forearm grip is known.

Find: Draw a free body diagram of each spring, each handle, the housing (rings) and the Iron Arms assembly when the handles have each been rotated 90 degrees inside the housing from a grip torque.

Assumptions:

3. No gravitational forces or frictional forces are applied to the components.
4. The unit is at static equilibrium at the rotated position.
5. A pure torque is applied to each handle grip.

Schematic and Given Data: See FIGURE P2.2 in the textbook.

Analysis:

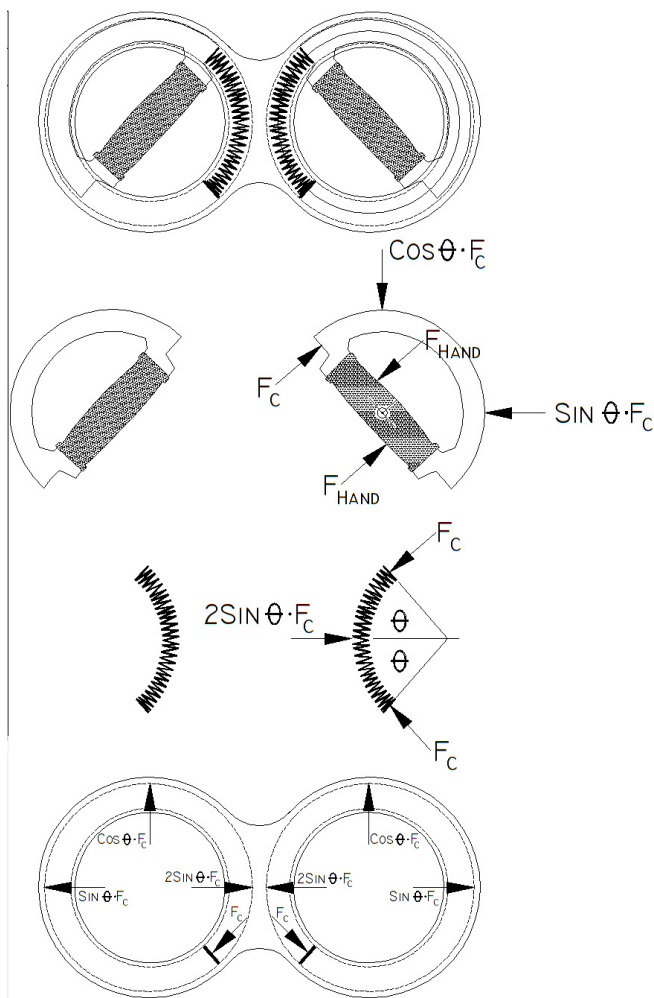

SOLUTION (2.4)

Known: A steel cable is tensioned using two methods.

Find: What is the tension in the steel cable if (a) one person on each end pulls with a force of 75 lb and (b) one end of the cable is attached directly and permanently to a tree and a person pulls on the other end with a force of 75 lb?

Analysis: The tension in the steel cable is 75 lb for case (a) and case (b).

SOLUTION (2.5D)

Known: Forces act on a person when walking.

Find: What forces act on a person when walking on a level roadway? What forces act on a person walking on a level belt of a treadmill? Which activity takes more effort?

Assumptions:

1. The treadmill belt velocity is equal to the velocity of the person walking on level ground.
2. The roadway is firm, clear of debris and possesses a coefficient of friction similar to the treadmill belt.
3. The person uses the same shoes for both activities.

Analysis:

1. The forces acting on a person walking on a level roadway are:
 - (a) Vertical force resisting gravity through the shoe/ground interface
 - (b) Drag force from the surrounding air on the walker. This could be an assisting or retarding force relative to the path of travel.
 - (c) Traction force at the shoe/ground interface providing the means for forward travel.
2. The forces acting on a person walking on a level treadmill belt are:
 - (a) Vertical force resisting gravity through the shoe/belt interface
 - (b) Traction force from the shoe to the tread belt interface.
3. The person walking outside generally requires more effort due to wind resistance forces for calm atmospheric conditions. For this reason a treadmill should be raised to 0.5° or 1.0° to simulate outdoors walking.

Comments: The net sum of tread belt forces results in three conditions. If the tractive force applied by the user is less than the tractive force from the tread belts movement the result is the user will move in the direction the tread belt rearward (and ultimately off the treadmill!). If the two tractive forces are nearly equivalent the user remains relatively stationary. If the user's applied tractive force is larger than the tread belt tractive force the user will move forwards relative to the treadmill.

SOLUTION (2.6Dnew)

Known: A motorcycle of weight W is shown in textbook Figure P2.6D. The two tires carry the weight of the motorcycle and passenger(s) as well as the forces generated during braking and steering. The motorcycle has a wheelbase of length L . The center of gravity is a distance c forward of the rear axle and a distance of h above the ground. The coefficient of friction between the pavement and the tires is μ .

Find: Draw a free-body diagram for the motorcycle for (a) rear wheel braking only, (b) front wheel braking only, and (c) front and rear wheel braking. Also, determine the magnitudes of the forces exerted by the roadway on the two tires during braking for the above cases.

Schematic and Given Data:

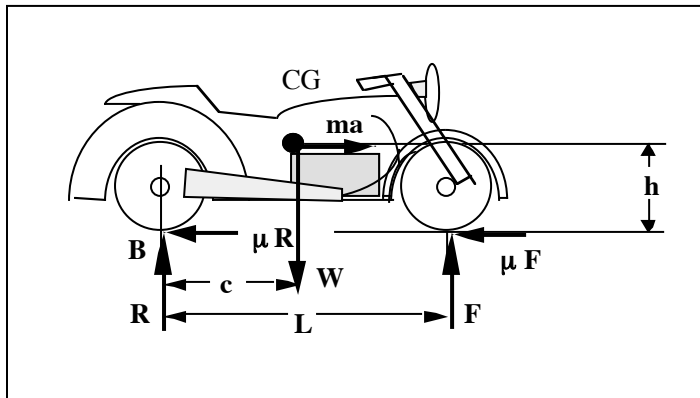

Assumptions:

1. The friction force is constant during braking.
2. The friction coefficient is identical for the front and rear tire-road interface.
3. The vehicle deceleration is uniform.

Analysis: Part (c) front and rear wheel braking.

1. From summation of moments (positive clockwise) about point B,
 $-F(L) + (ma)h + cW = 0$
2. From summation of forces in the vertical direction,
 $+R - W + F = 0$
3. From summation of forces in the horizontal direction,
 $+(ma) - \mu R - \mu F = 0$
4. Solving by eliminating (ma) and R gives
 $-FL + \mu hW + cW = 0$
5. Solving for F gives, $F = \frac{W(c + \mu h)}{L}$

Comment:

1. With the motorcycle stationary, the static force on the front tire is $F = Wc/L$.
2. Note that the reverse effective deceleration force ($F=ma$) is equal to the friction forces (μR and μF) that the pavement exerts on the front and rear tires.

SOLUTION (2.7new)

Known: A motorcycle of weight, $W = 1000$ lb is shown in Figure P2.6D of the textbook. The two tires carry the weight of the motorcycle and passenger(s) as well as the forces generated during braking and steering. The motorcycle has a wheelbase of length $L = 70$ in. The center of gravity is a distance $c = 38$ in. forward of the rear axle and a distance of $h = 24$ in. above the ground. The coefficient of friction between the pavement and the tires is $\mu = 0.7$.

Find: Determine the forces on the rear wheel of the motorcycle for (a) rear wheel braking only, and (b) front wheel braking only. (Also, draw a free-body diagram for the motorcycle.)

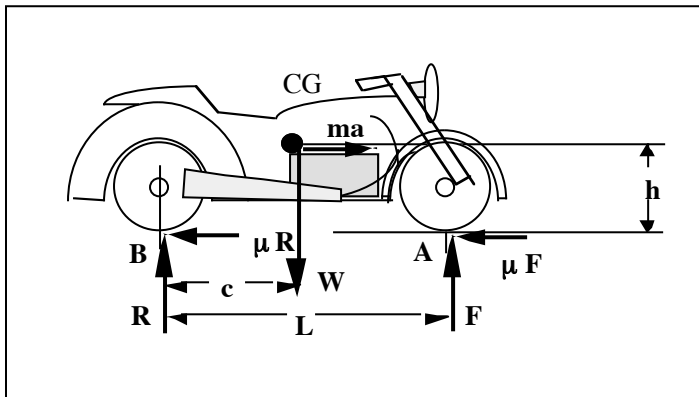
Schematic and Given Data:**Assumptions:**

1. The friction force is constant during braking.
2. The friction coefficient is identical for the front and rear tire-road interface.
3. The vehicle deceleration is uniform.

Analysis:

Part (a) -- rear wheel braking only.

1. From summation of moments (positive clockwise) about point A,
 $R(L) + (ma)h - W(L-c) = 0$
2. From summation of forces in the vertical direction,
 $+R - W + F = 0$
3. From summation of forces in the horizontal direction,
 $+(ma) - \mu R = 0$
4. Combining the equations of part 1 and part 3 by eliminating (ma) gives
 $R(L) + (\mu R)h - (L-c)W = 0$
5. Solving for R gives, $R = \frac{W(L-c)}{L + \mu h} = \frac{1000 \text{ lb} (70 \text{ in.} - 38 \text{ in.})}{70 \text{ in.} + 0.7 (24 \text{ in.})} = 368.7 \text{ lb}$
6. The friction force on the rear tire $(\mu R) = 0.7 (368.7) = 258 \text{ lb.}$

Analysis: Part (b) -- front wheel braking only.

1. From summation of moments (positive clockwise) about point B,
 $-F(L) + (ma)h + cW = 0$
2. From summation of forces in the vertical direction,
 $+R - W + F = 0$
3. From summation of forces in the horizontal direction,
 $+(ma) - \mu F = 0$
4. Combining the equations of part 1 and part 3 by eliminating (ma) gives
 $-FL + (\mu F)h + cW = 0$
5. Solving for F gives, $F = \frac{cW}{(L - \mu h)} = \frac{38 \text{ in.}(1000 \text{ lb})}{70 \text{ in.} - 0.7(24 \text{ in.})} = 714.3 \text{ lb}$
6. The rear wheel force is $R = W - F = 1000 - 714.3 = 286.6 \text{ lb}$

Comment:

1. With the motorcycle stationary, the static force on the front tire is $F = Wc/L$.
2. Note that the reverse effective deceleration force ($F = ma$) is equal to the friction forces (μR and/or μF) that the pavement exerts on the front and/or rear tires.

SOLUTION (2.8new)

Known: An automobile of weight W and wheelbase L slides while braking on pavement having a given coefficient of friction. The location of the center of gravity is specified.

Find: Draw a free-body diagram of the automobile.

Schematic and Given Data:

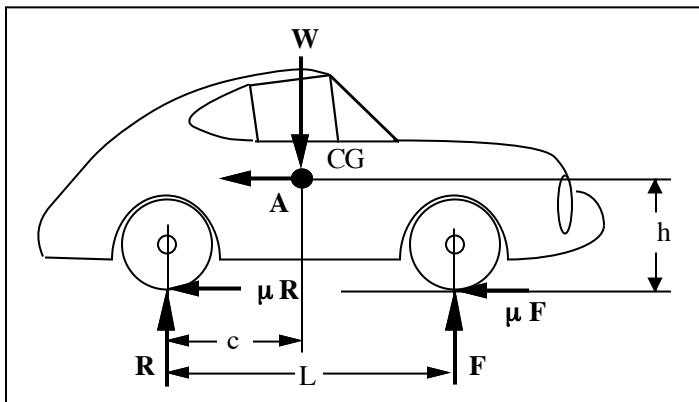

Assumptions:

1. The friction force is constant during braking.
2. The vehicle deceleration is uniform.
3. The motor exerts negligible torque on the wheels (the motor is disconnected).

Analysis:

1. From summation of moments at point R,

$$\sum M_R = -F(L) - Ah + Wc = 0$$

2. From summation of forces in the vertical direction,

$$\sum F_y = 0 = R - W + F = 0$$

3. From summation of forces in the horizontal direction,

$$\sum F_x = 0 = A + \mu R + \mu F = 0$$

4. Solving by eliminating A and R gives

$$-FL + \mu hW + Wc = 0$$

5. Solving for F gives, $F = \frac{W(c + \mu h)}{L}$

Comment: For a 4000 lb vehicle, with $L = 120$ in., $h = 26$ in., $c = 70$ in., and $\mu = 0.7$:

1. $F = 4000 \text{ lb} \frac{[70 \text{ in} + (0.7)(26 \text{ in})]}{120} = 2940 \text{ lb}$

2. With the vehicle stationary, the static force on the two front tires is 2330 lb.

SOLUTION (2.9 new)

Known: An automobile of weight $W = 4000$ lb, wheel base $L = 117$ in., $c = 65$ in. and $h = 17.5$ in slides while braking on pavement with a coefficient of friction of 0.7. (The location of the center of gravity is specified.)

Find: Determine the force on each of the rear tires. (Start by drawing a free-body diagram of the automobile.)

Schematic and Given Data:

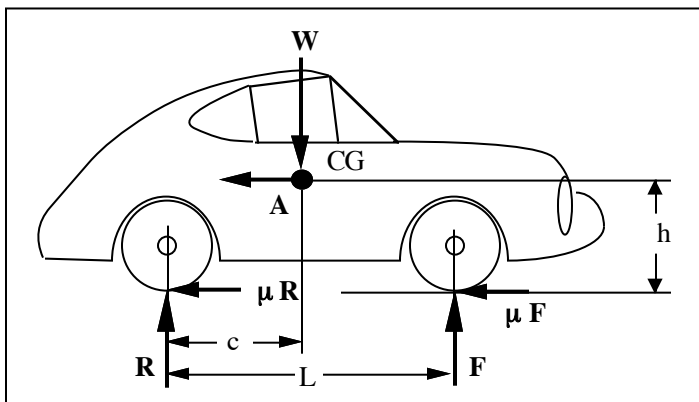

Assumptions:

1. The friction force is constant during braking.
2. The vehicle deceleration is uniform.
3. The motor exerts negligible torque on the wheels (the motor is disconnected).
4. The friction force is shared equally by each of the rear wheels.

Analysis:

1. From summation of moments at point R,

$$\sum M_R = -F(L) - Ah + Wc = 0$$
2. From summation of forces in the vertical direction,

$$\sum F_y = 0 = R - W + F = 0$$
3. From summation of forces in the horizontal direction,

$$\sum F_x = 0 = A + \mu R + \mu F = 0$$
4. Solving by eliminating A and F gives

$$RL - WL + \mu h W + Wc = 0$$
5. Solving for R gives, $R = \frac{W(L - c - \mu h)}{L}$
6. For a 4000 lb vehicle, with $L = 117$ in., $h = 17.5$ in., $c = 65$ in., and $\mu = 0.7$:
7. $R = \frac{W(L - c - \mu h)}{L} = \frac{4000 \text{ lb}(117 \text{ in.} - 65 \text{ in.} - (0.7)(17.5 \text{ in.}))}{117 \text{ in.}} = 1358 \text{ lb}$
8. The upward force on each rear tire is $1358/2 = 679$ lb. The friction force on each rear tire force is $(0.7)(679 \text{ lb}) = 475.3$ lb. The total force then on each rear tire is $\sqrt{679^2 + 475.3^2} = 827.6$ lb.

SOLUTION (2.10new)

Known: An automobile of weight W_{car} and wheelbase L slides while braking on pavement with a given coefficient of friction. The location of the center of gravity is specified (as in Problem 2.8). The automobile is towing a one-axle trailer of weight W_{trailer} .

Find: Determine the minimum stopping distance for the automobile and trailer assuming (a) no braking on the trailer and (b) full braking on the trailer. What is the minimum stopping distance for the automobile if it is not towing a trailer?

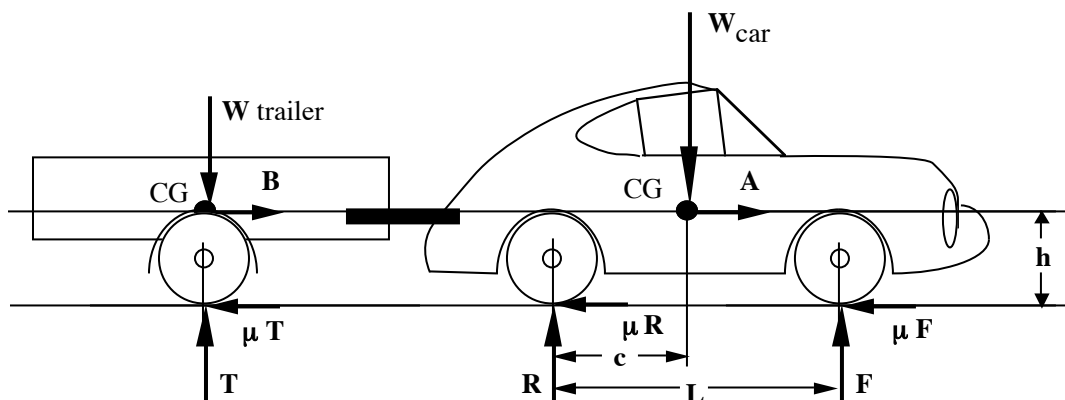
Schematic and Given Data:

Assumptions:

1. The friction force is constant during braking.
2. The vehicle deceleration is uniform.
3. The center of gravity of the trailer and the car are at the same height from the ground.
4. The coupler connecting the trailer to the car is horizontal and at the same height as the center of gravity for the trailer.
5. The center of gravity for the trailer is directly over the trailer tires.
6. The coupler does not transmit a bending moment.

Analysis:

1. We first determine the stopping distance, S , for full braking on the car and the trailer.
2. The kinetic energy of the car and trailer is given by $KE = (1/2) m_{\text{car}} V_{\text{car}}^2 + (1/2) m_{\text{trailer}} V_{\text{trailer}}^2$.
3. The work done in stopping the car is $\mu W_{\text{car}} S$ where S is the minimum stopping distance and μ is the maximum tire-pavement friction coefficient.
4. The work done in stopping the trailer is $\mu W_{\text{trailer}} S$ where S is the minimum stopping distance and μ is the maximum tire-pavement friction coefficient.
5. The kinetic energy of the car and trailer equals the work done to stop the car and trailer or $KE = \mu W_{\text{car}} S + \mu W_{\text{trailer}} S$.
6. Solving for S , we have

$$S = \frac{\frac{1}{2} [m_{\text{car}} + m_{\text{trailer}}] V^2}{\mu m_{\text{car}} g + \mu m_{\text{trailer}} g}$$

7. With no braking on the trailer, the pavement will not exert a friction force on the trailer tires and

$$S = \frac{\frac{1}{2} [m_{\text{car}} + m_{\text{trailer}}] V^2}{\mu m_{\text{car}} g}$$

8. If the car is not towing a trailer,

$$S = \frac{\frac{1}{2} [m_{\text{car}}] V^2}{\mu m_{\text{car}} g}$$

Comment:

1. With a 4000 lb car, a 2000 lb trailer, $\mu = 0.7$, and a speed of 60 mph (88 feet/s), the stopping distance for the car without the trailer is $S = (1/2)V^2/\mu g = 171.8$ feet. This is also the stopping distance for the car with the trailer braking with the same tire-pavement friction coefficient. The stopping distance for the car and trailer without trailer braking is $\frac{[m_{\text{car}}+m_{\text{trailer}}]}{m_{\text{car}}} = 1.5$ times farther.
2. An interesting exercise is to calculate the forces acting on the car and trailer during braking (while considering the necessity of the assumptions that were given).

SOLUTION (2.11new)

Known: An automobile of weight W and wheelbase L slides while braking on pavement with a given coefficient of friction. The location of the center of gravity is specified. The automobile is traveling downhill at a grade of 10:1.

Find: Draw a free-body diagram of the automobile as it is traveling downhill.

Schematic and Given Data:

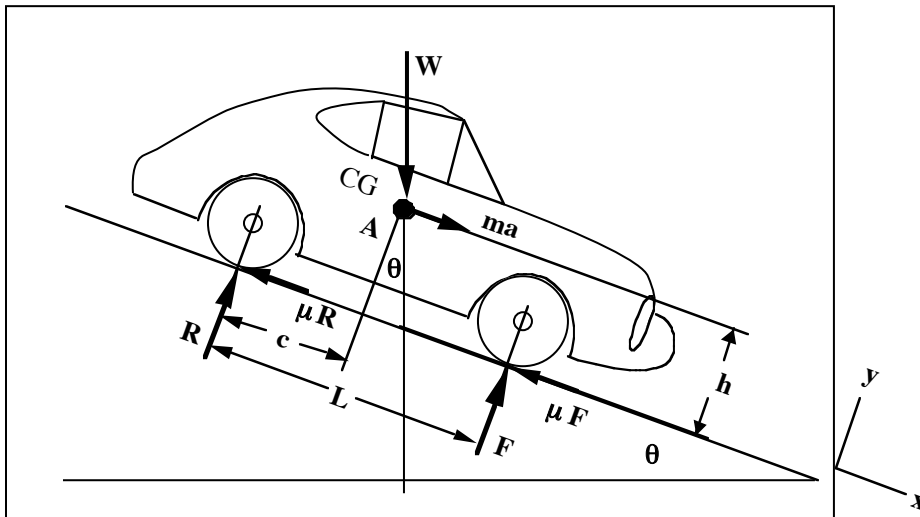

Assumptions:

1. The friction force is constant during braking.
2. The vehicle deceleration is uniform.

Analysis:

1. From summation of moments (positive clockwise) about point B, where B is the contact “point” of the rear tire with the roadway and where A = ma (the reverse effective deceleration force),

$$-F(L) + Ah + c(W\cos \theta) + h(W\sin \theta) = 0$$

2. From summation of forces in the y-direction,

$$R - W\cos\theta + F = 0$$

3. From summation of forces in the x-direction,

$$A + W\sin\theta - \mu R - \mu F = 0$$

4. Solving by eliminating A and R gives

$$-FL + h[-W\sin\theta + \mu(W\cos\theta - F) + \mu F] + cW\cos\theta + hW\sin\theta = 0$$

5. Solving for F gives, $F = \frac{W(c + \mu h)}{L} \cos \theta$

Comment: For a 4000 lb vehicle, with $L = 120$ in., $h = 26$ in., $c = 70$ in., $\theta = \tan^{-1}(1/10) = 5.71^\circ$, and $\mu = 0.7$, we have $F = 2925.4$ lb.

SOLUTION (2.12D)

Known: A vertical wall channel C holds solid cylindrical rods A and B of known density. The width of channel C is not given.

Find: Select a metal for rods A and B. Draw free body diagrams for rod A, rod B, and channel C. Determine the magnitude of the forces acting on A, B, and C.

Schematic and Given Data:

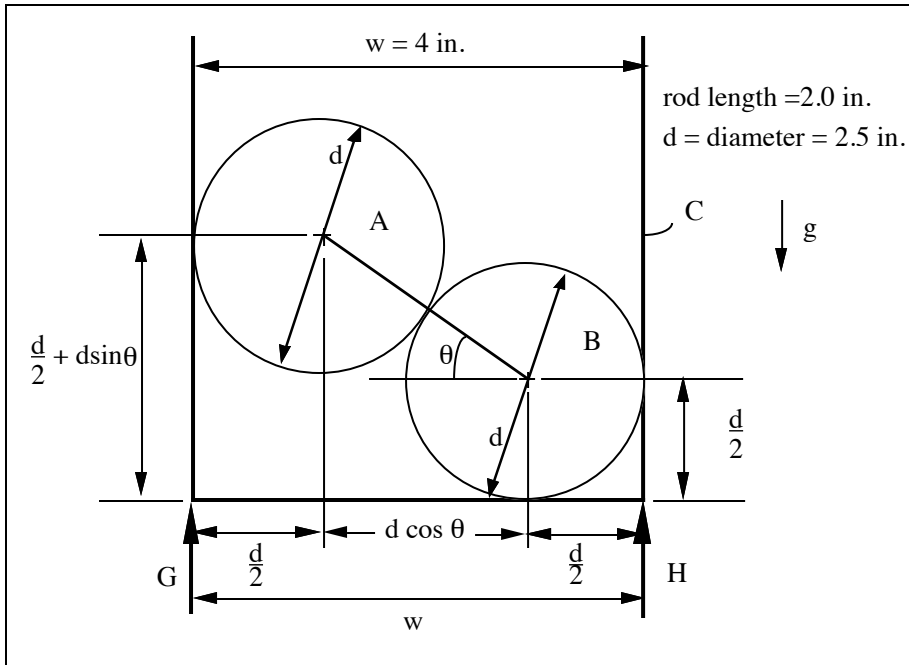

Decisions:

1. Select steel which has a known density of $\rho = 0.28$ lbm/in.³.
2. Select $w = 4.0$ in. for analysis.

Assumptions:

1. The channel is open upward and supported on the bottom by two knife edges at G and H.
2. The friction forces between the contacting bodies are negligible.
3. The rods A and B and channel C are in static equilibrium.
4. The force of gravity is the only body force.
5. The weight of the channel C is negligible.

Analysis:

1. From the free body diagram for A: $D = \left[\frac{W}{\sin \theta} \right]$, $C = \left[\frac{W}{\tan \theta} \right]$.
2. From the free body diagram for B: $E = \left[\frac{W}{\tan \theta} \right]$, $F = 2W$.

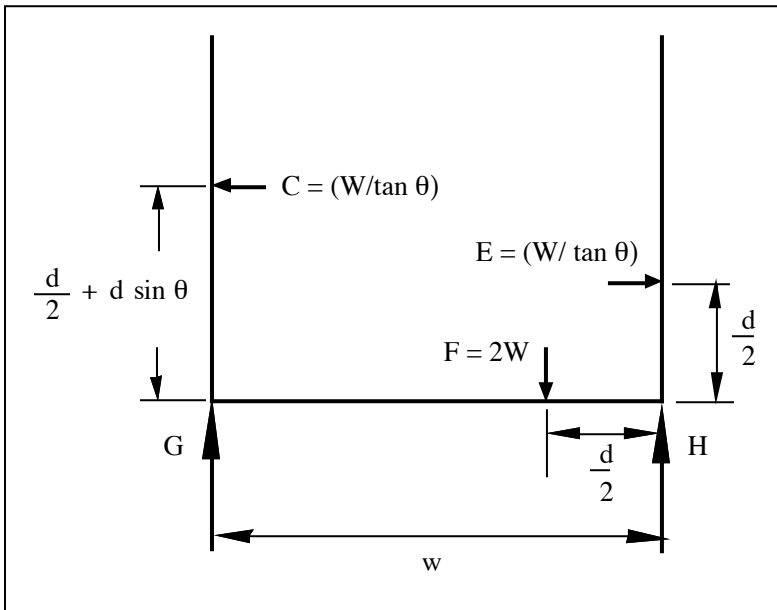
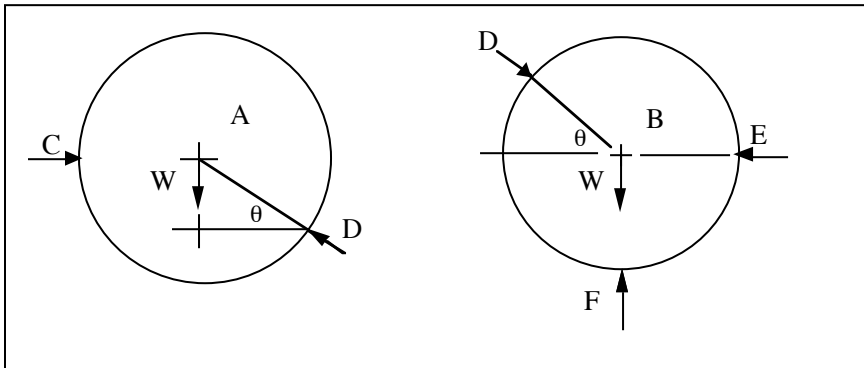

3. For $w = 4$ in., $d = 2.5$ in, and rod length $L = 2.0$ in.; the rod mass $= \rho V = (0.28 \text{ lbm/in.}^3)(2.0 \text{ in.})(\pi)(1.25)^2/4 = 0.687 \text{ lbm}$.
4. The weight of each rod is $W = F = ma = (0.687 \text{ lbm})(32.2 \text{ ft/s}^2)/g_c = 0.687 \text{ lb}$.

5. $\theta = \cos^{-1}((4-d)/d) = 53.13^\circ$.
6. $D = .858 \text{ lb}$, $C = .515 \text{ lb}$, $E = .515 \text{ lb}$, $F = 1.374 \text{ lb}$.
7. From the free body diagram for the channel, the forces G and H can be obtained from force equilibrium.

Comments:

1. An assumption had to be made about the forces that the surroundings exert on channel C. In order to simplify the analysis, it was assumed that point forces from the "ground" acted at G and H.
 2. To apply the equations of force equilibrium, the channel C should be supported such that it is in stable equilibrium.
 3. To consider the container as a free body, all the forces from the surroundings acting on the body must be shown.
-

SOLUTION (2.13Dnew)

Known: Two spheres A and B are in a container C.

Find: Draw the free body diagrams of A, B, and C. Also determine the forces acting on these bodies.

Schematic and Given Data:

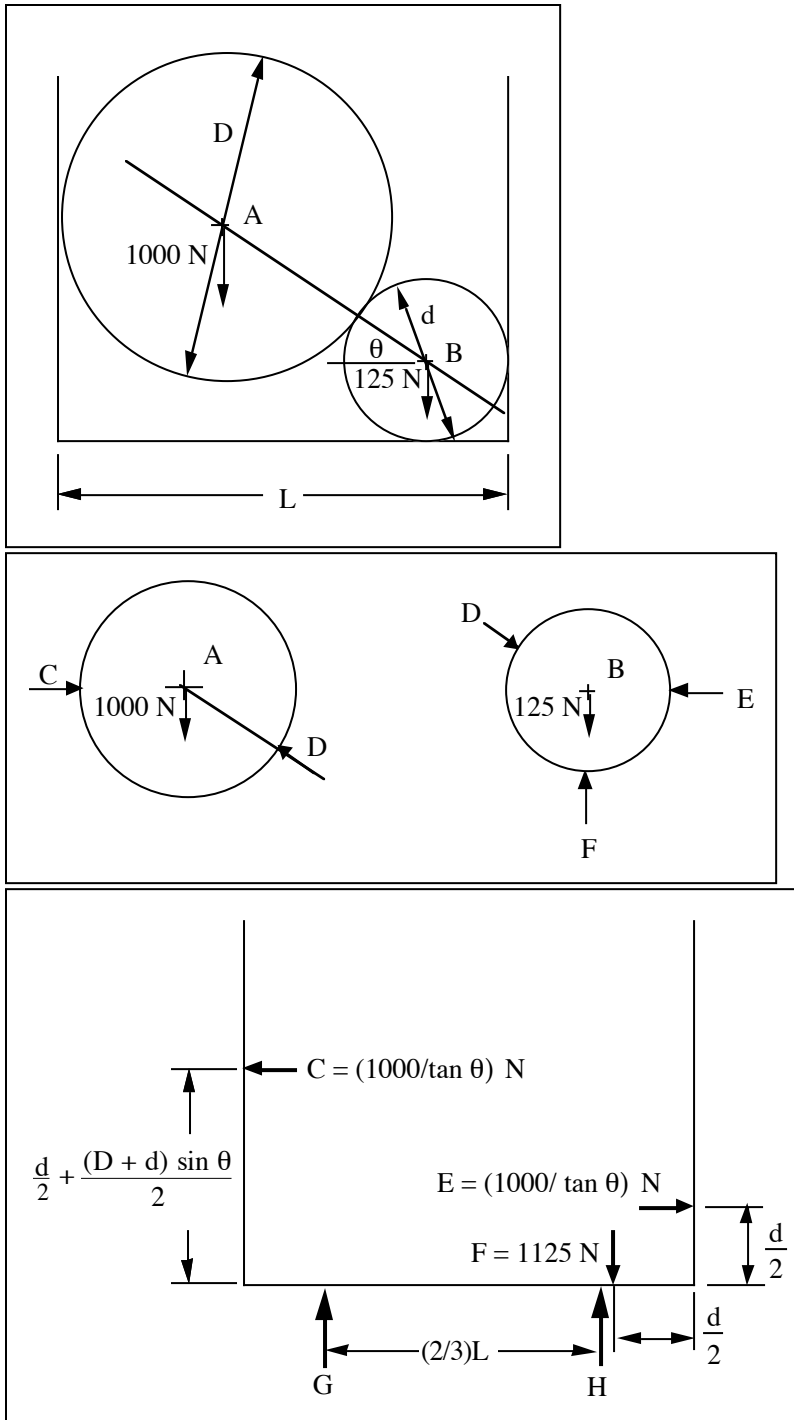

Assumptions:

1. The container is cylindrical in shape and supported on two knife edges, each at a distance of $(1/3)L$ (where L is the diameter of the container cross section) from the base circle center or $(2/3)L$ apart.
2. The friction forces between the contacting bodies are negligible.
3. The sphere and containers are in static equilibrium.
4. The force of gravity is the only body force.

Analysis:

1. From the free body diagram for A, $D = \left[\frac{1000}{\sin \theta} \right] \text{ N}$, $C = \left[\frac{1000}{\tan \theta} \right] \text{ N}$.
2. From the free body diagram for B, $E = \left[\frac{1000}{\tan \theta} \right] \text{ N}$, $F = 1125 \text{ N}$.

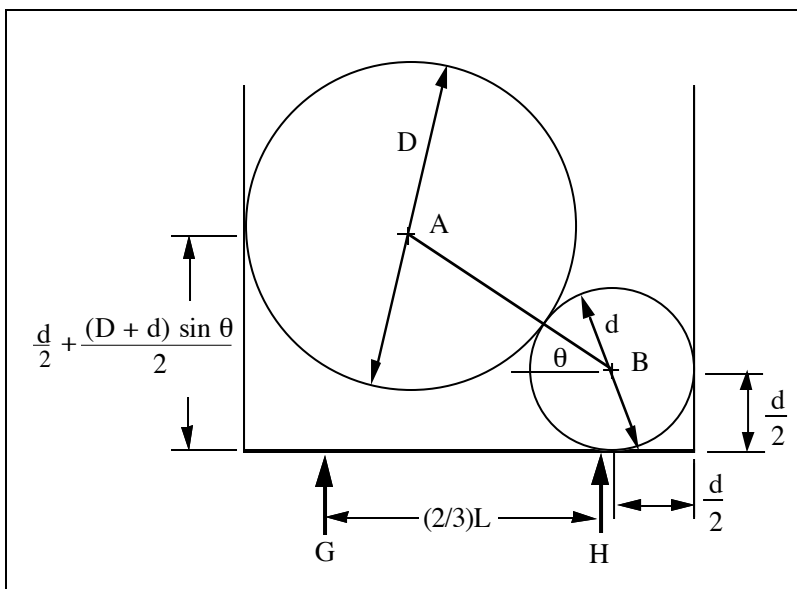

3. From the above diagram and the free body diagram for C, the forces G and H can be obtained.

Comments:

1. The geometry of the container must be clearly determined before proceeding to solve this problem. For example, if the container is assumed to be rectangular in shape, then the spheres would not be in stable equilibrium. Also, until the container shape is defined it is impossible to draw the free body diagram.
2. The container should be supported such that it is in stable equilibrium. To consider the container as a free body, all the forces from the surroundings acting on the body must be shown.

SOLUTION (2.14new)

Known: The geometry and the loads acting on a pinned assembly are given.

Find: Draw a free-body diagram for the assembly and determine the magnitude of the forces acting on each member of the assembly.

Schematic and Given Data:

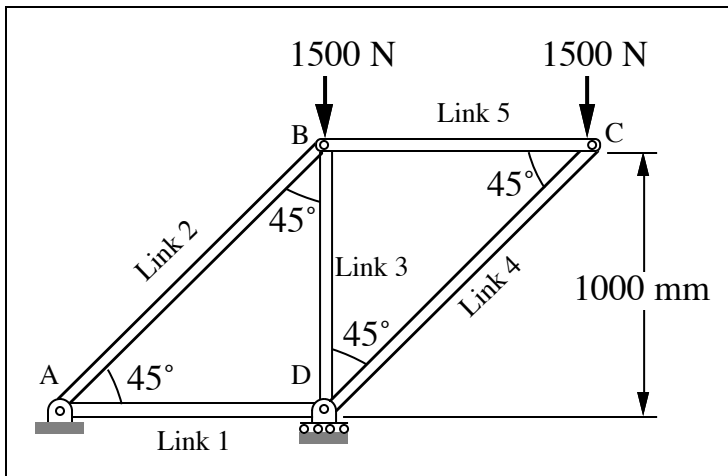

Assumptions:

1. The links are rigid.
2. The pin joints are frictionless.
3. The weight of the links are negligible.
4. The links are two force members and are either in tension or compression.

Analysis:

1. We first draw a free-body diagram of the entire structure.

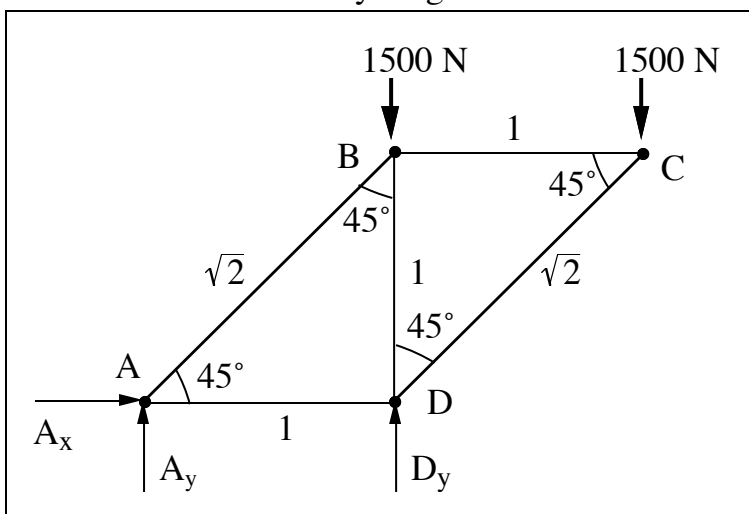

2. Taking moments about point A and assuming clockwise moments to be positive,
$$\sum M_A = 0 = 1500(2) + 1500(1) - D_y(1)$$
3. Solving for D_y gives $D_y = 4500$ N.
4. Summation of forces in the y-direction and assuming vertical forces positive,
$$\sum F_y = 0 = A_y + D_y - 1500 - 1500 = A_y + D_y - 3000.$$

5. Since, $D_y = 4500 \text{ N}$, $A_y = 3000 - D_y = -1500 \text{ N}$.
6. $\sum F_x = 0$ gives, $A_x = 0$.
7. We now draw a free-body diagram for a section at C.

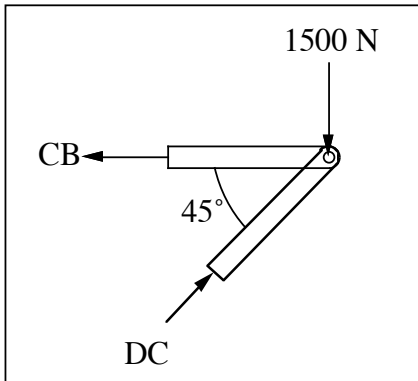

8. $\sum F_x = 0 = -CB + DC \sin 45^\circ$ and
 $\sum F_y = 0 = DC \sin 45^\circ - 1500$
9. Solving simultaneous equations gives $DC = 2121 \text{ N}$, $CB = 1500 \text{ N}$.
10. We now draw a free-body diagram for a section at A.

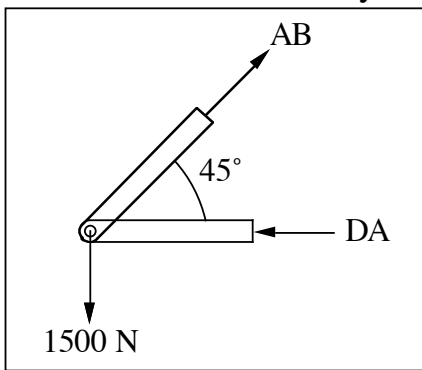

11. $\sum F_y = 0 = AB \sin 45^\circ - 1500$
 $\sum F_x = 0 = AB \cos 45^\circ - DA$
12. Solving simultaneous equations gives $AB = 2121 \text{ N}$, $DA = 1500 \text{ N}$.
13. We now draw a free-body diagram for a section at D.

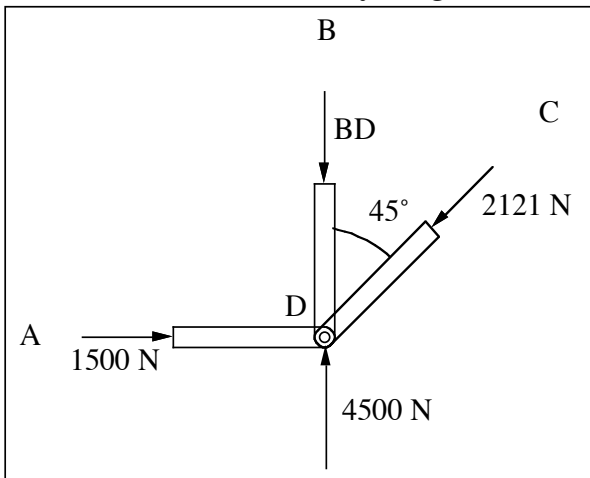

14. $\sum F_y = 0 = 4500 - BD - 2121(\sin 45^\circ)$

Hence, $BD = 3000 \text{ N}$.

15. The free-body diagrams for links DC, BC, AB, AD, and BD are:

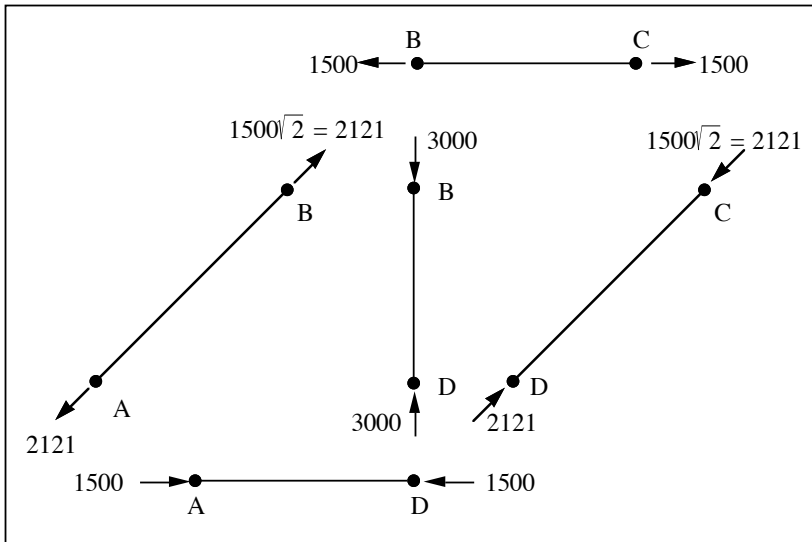

16. We can now draw a free-body diagram of pin B:

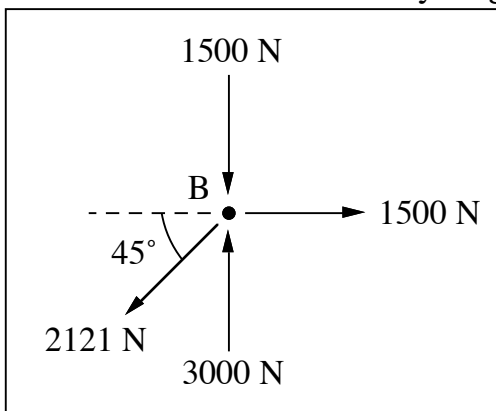

17. Checking for static equilibrium at pin B gives:

$$\sum F_x = 2121 \cos 45^\circ - 1500 = 0$$

$$\sum F_y = 1500 + 2121 \sin 45^\circ - 3000 = 0$$

18. We can also draw a free-body diagram for pin C:

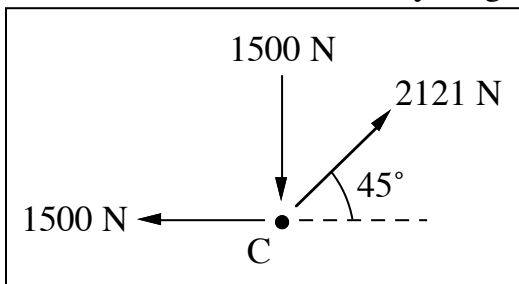

19. Checking for static equilibrium at pin C gives:

$$\sum F_x = 1500 - 2121 \cos 45^\circ = 0$$
$$\sum F_y = 1500 - 2121 \sin 45^\circ = 0$$

Comment: From force flow visualization, we determine that links 1, 3, and 4 are in compression and that links 2 and 5 are in tension.

SOLUTION (2.15new5e)

Known: The geometry and the loads acting on a pinned assembly are given.

Find: Draw a free-body diagram for the assembly and determine the magnitude of the forces acting on each member of the assembly.

Schematic and Given Data:

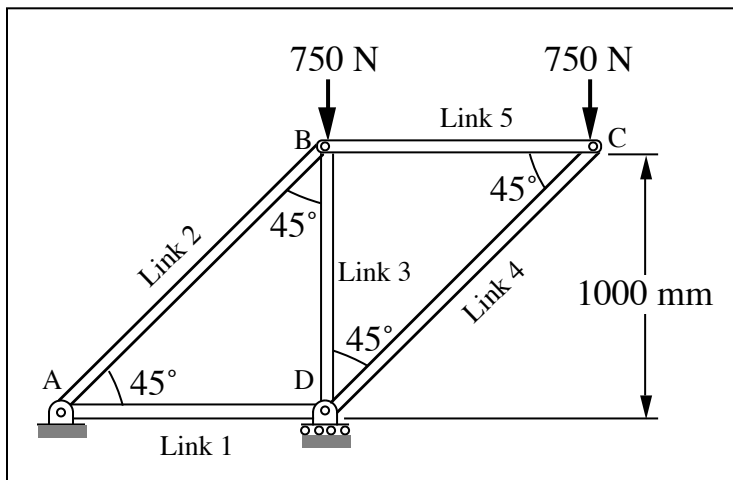

Assumptions:

1. The links are rigid.
2. The pin joints are frictionless.
3. The weight of the links are negligible.
4. The links are two force members and are either in tension or compression.

Analysis:

1. We first draw a free-body diagram of the entire structure.

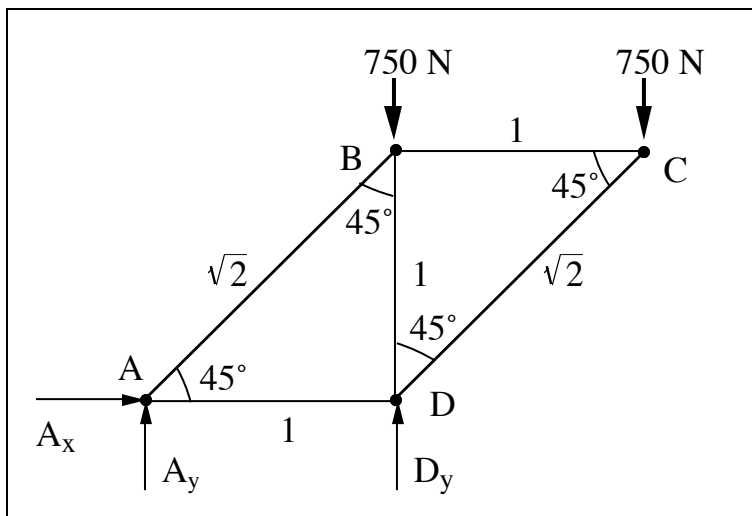

2. Taking moments about point A and assuming clockwise moments to be positive,

$$\sum M_A = 0 = 750(2) + 750(1) - D_y(1)$$
3. Solving for D_y gives $D_y = 2250$ N.
4. Summation of forces in the y-direction and assuming vertical forces positive,

$$\sum F_y = 0 = A_y + D_y - 750 - 750 = A_y + D_y - 1500.$$
5. Since, $D_y = 2250$ N, $A_y = 1500 - D_y = -750$ N.
6. $\sum F_x = 0$ gives, $A_x = 0$.
7. We now draw a free-body diagram for a section at C.

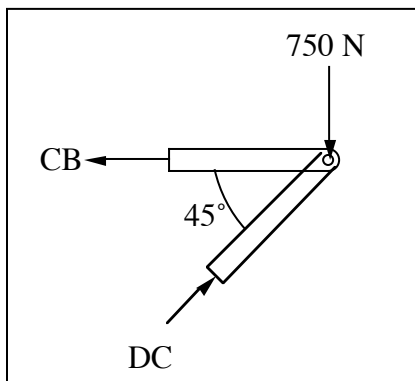

8.
$$\sum F_x = 0 = -CB + DC \sin 45^\circ$$
 and

$$\sum F_y = 0 = DC \sin 45^\circ - 750$$
9. Solving simultaneous equations gives $DC = 1060.6$ N, $CB = 750$ N.
10. We now draw a free-body diagram for a section at A.

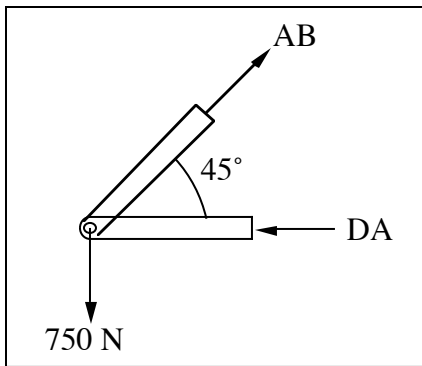

$$11. \sum F_y = 0 = AB \sin 45^\circ - 750$$

$$\sum F_x = 0 = AB \cos 45^\circ - DA$$

12. Solving simultaneous equations gives $AB = 1060.6 \text{ N}$, $DA = 750 \text{ N}$.

13. We now draw a free-body diagram for a section at D.

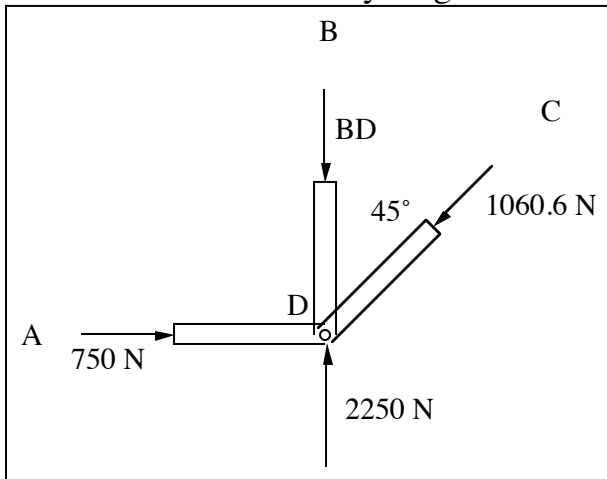

$$14. \sum F_y = 0 = 2250 - BD - 1060.6(\sin 45^\circ)$$

Hence, $BD = 1500 \text{ N}$.

15. The free-body diagrams for links DC, BC, AB, AD, and BD are:

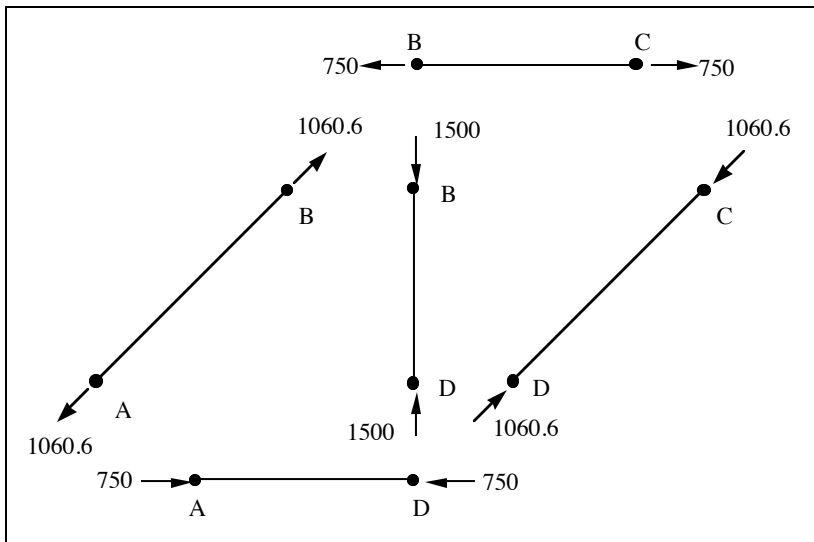

16. We can now draw a free-body diagram of pin B:

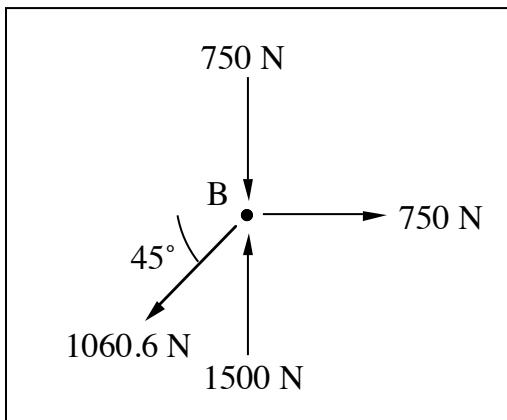

17. Checking for static equilibrium at pin B gives:

$$\sum F_x = 1060.6 \cos 45^\circ - 750 = 0$$

$$\sum F_y = 750 + 1060.6 \sin 45^\circ - 1500 = 0$$

18. We can also draw a free-body diagram for pin C:

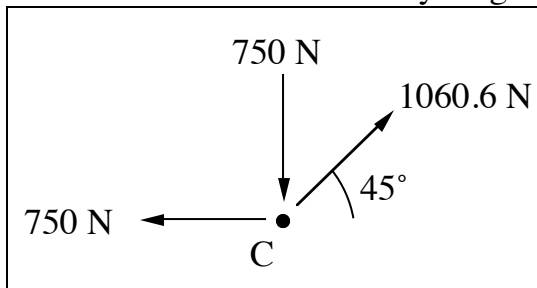

19. Checking for static equilibrium at pin C gives:

$$\sum F_x = 750 - 1060.6 \cos 45^\circ = 0$$

$$\sum F_y = 750 - 1060.6 \sin 45^\circ = 0$$

Comment: From force flow visualization, we determine that links 1, 3, and 4 are in compression and that links 2 and 5 are in tension.

SOLUTION (2.16new)

Known: A 1800 rpm motor is rotating a blower at 6000 rpm through a gear box having a known weight.

Find: Determine all loads acting on the gear box when the motor output is 1 hp, and sketch the gear box as a free-body in equilibrium.

Schematic and Given Data:

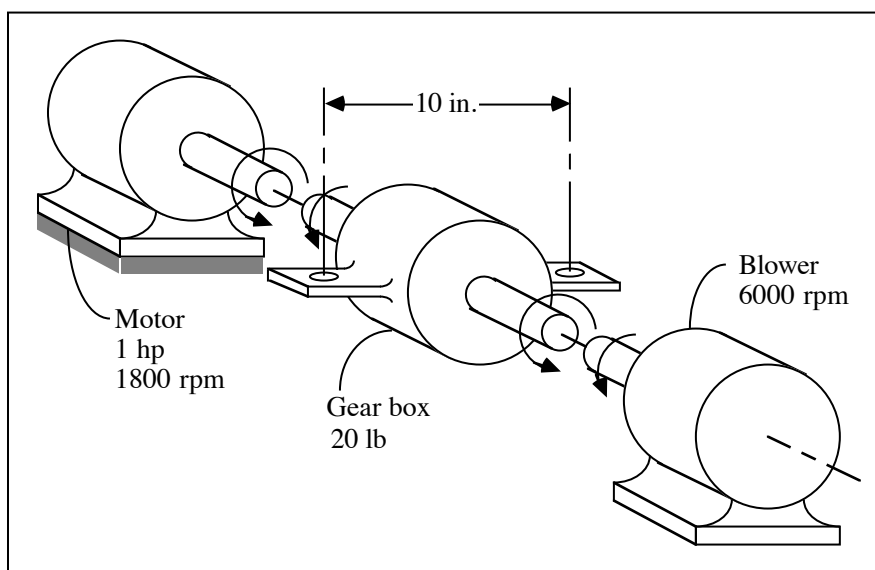

Assumption: The friction losses in the gear box are negligible.

Analysis:

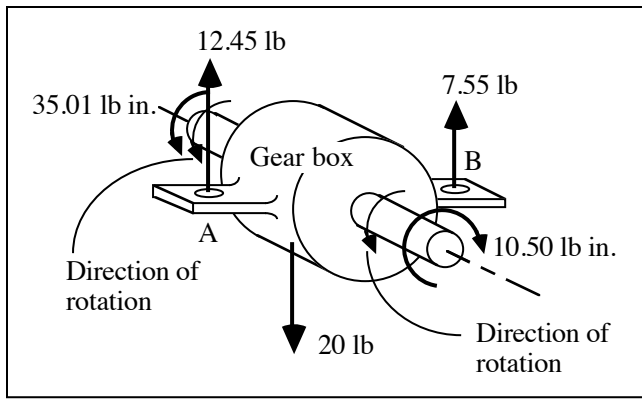

1. From Eq. (1.3), $T = \frac{5252 \cdot \dot{W}}{n} = \frac{5252(1)}{1800}$
 $T = 2.92 \text{ lb}\cdot\text{ft} = 35.01 \text{ lb}\cdot\text{in.}$ (motor shaft)
2. To the blower, $T = 35.01 \left(\frac{1800 \text{ rpm}}{6000 \text{ rpm}} \right) = 10.50 \text{ lb}\cdot\text{in.}$ (to blower)
3. Mounting torque reaction = $35.01 - 10.50 = 24.51 \text{ lb}\cdot\text{in.}$
4. Mounting forces = $24.51 \text{ lb}\cdot\text{in.} / 10 \text{ in.} = 2.45 \text{ lb.}$ The mounting force acts upward at A and downward at B.
5. Add 10 lb acting upward at A and B to support the gravity load, giving 12.45 lb upward at A and 7.55 lb upward at B.

SOLUTION (2.17new5e)

Known: A 1800 rpm motor is rotating a blower at 6000 rpm through a gear box having a weight of 40 lb.

Find: Determine all loads acting on the gear box when the motor output is 1 hp, and sketch the gear box as a free-body in equilibrium.

Schematic and Given Data:

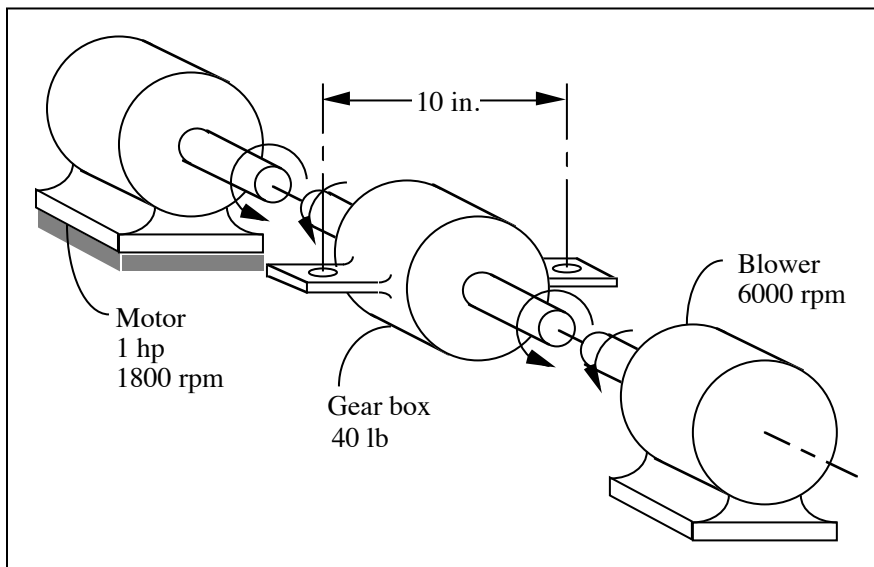

Assumption: The friction losses in the gear box are negligible.

Analysis:

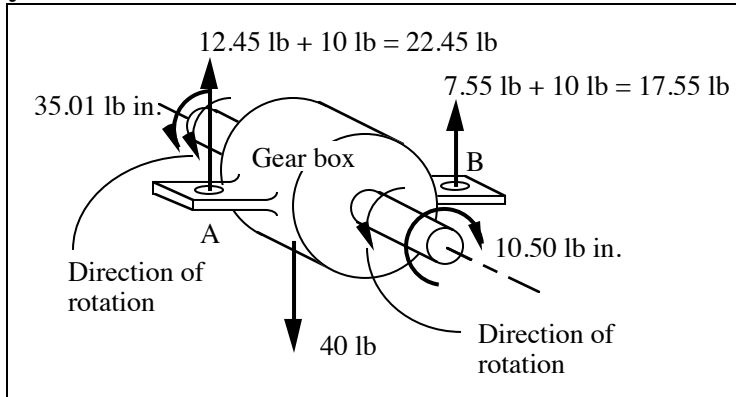

- From Eq. (1.3), $T = \frac{5252 \cdot \dot{W}}{n} = \frac{5252(1)}{1800}$
 $T = 2.92 \text{ lb}\cdot\text{ft} = 35.01 \text{ lb}\cdot\text{in.}$ (motor shaft)
- To the blower, $T = 35.01 \left(\frac{1800 \text{ rpm}}{6000 \text{ rpm}} \right) = 10.50 \text{ lb}\cdot\text{in.}$ (to blower)
- Mounting torque reaction = $35.01 - 10.50 = 24.51 \text{ lb}\cdot\text{in.}$
- Mounting forces = $24.51 \text{ lb}\cdot\text{in.} / 10 \text{ in.} = 2.45 \text{ lb.}$ The mounting force acts upward at A and downward at B.
- Add 20 lb acting upward at A and B to support the gravity load, giving 22.45 lb upward at A and 17.55 lb upward at B.

Comment: In textbook problem 2.16, the gear box weights 20 lb.

SOLUTION (2.18new)

Known: The motor operates at constant speed and develops a torque of 100 lb-in. during normal operation. A 5:1 ratio gear reducer is attached to the motor shaft; i.e., the reducer output shaft rotates in the same direction as the motor but at one-fifth the motor speed. Rotation of the reducer housing is prevented by the “torque arm,” pin-connected at each end as shown in Fig. P2.18. The reducer output shaft drives the load through a flexible coupling. Gravity and friction can be neglected..

Find: Determine the loads applied to (a) the torque arm, (b) the motor output shaft, and (c) the reducer output shaft.

Schematic and Given Data:

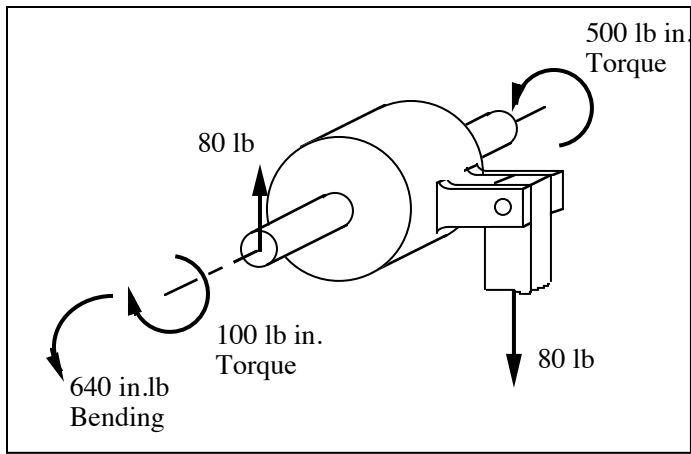

Assumption: The friction losses in the gear box are negligible.

Analysis:

1. The force in the torque arm is 80 lb tension.
 2. The loads on the reducer input shaft are 100 lb in. torque, plus 80 lb vertical load and 640 in lb bending moment in the plane of the motor face.
 3. The load on the reducer output shaft is 500 lb in. torque.
-

SOLUTION (2.19new)

Known: The motor operates at constant speed and develops a torque of 200 lb-in. during normal operation. A 5:1 ratio gear reducer is attached to the motor shaft; i.e., the reducer output shaft rotates in the same direction as the motor but at one-fifth the motor speed. Rotation of the reducer housing is prevented by the “torque arm,” pin-connected at each end as shown in Fig. P2.18. The reducer output shaft drives the load through a flexible coupling. Gravity and friction can be neglected..

Find: Determine the loads applied to (a) the torque arm, (b) the motor output shaft, and (c) the reducer output shaft.

Schematic and Given Data:

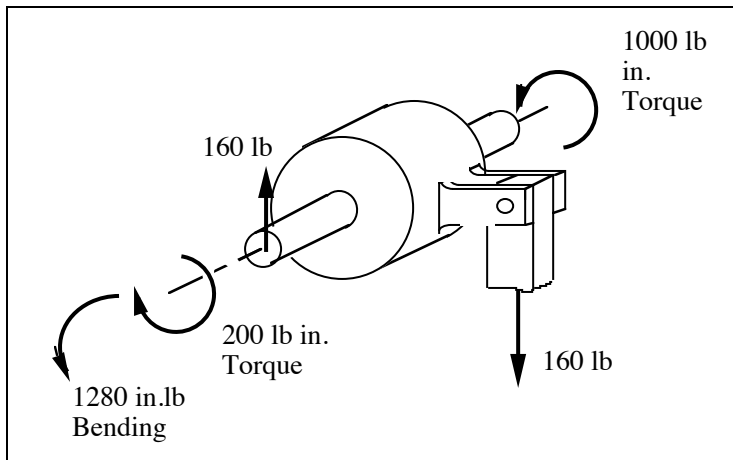

Assumption: The friction losses in the gear box are negligible.

Analysis:

1. The force in the torque arm is 160 lb tension.
2. The loads on the reducer input shaft are 200 lb in. torque, plus 160 lb vertical load and 1280 in lb bending moment in the plane of the motor face.
3. The load on the reducer output shaft is 1000 lb in. torque.

Comment: In textbook problem 2.18, the motor develops a torque of 100 lb in. during operation.

SOLUTION (2.20)

Known: The drawing in Fig. P2.20 shows the engine, transmission, and propeller shaft of a prototype automobile. The transmission and engine are not bolted together but are attached separately to the frame. The transmission weighs 100 lb, receives an engine torque of 100 lb-ft at A through a flexible coupling, and attaches to the propeller shaft at B through a universal joint. The transmission is bolted to the frame at C and D. Assume that the transmission ratio is -3; i.e., reverse gear with propeller shaft speed = -1/3 engine speed.

Find: Draw the transmission as a free body in equilibrium.

Schematic and Given Data:

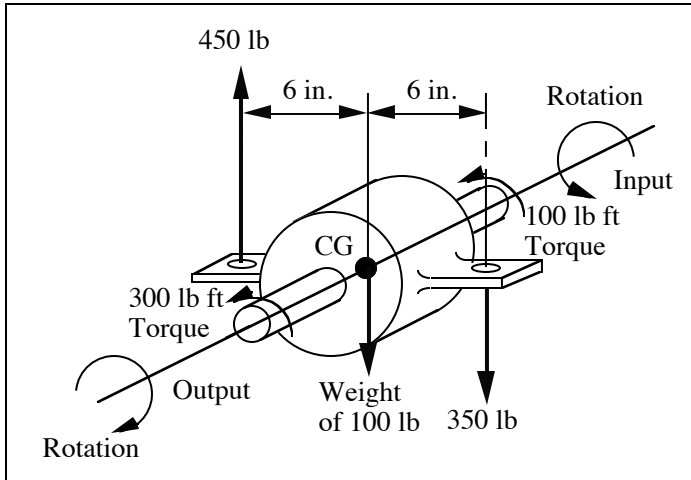

Assumption: The friction losses in the gear box are negligible.

Analysis: A free body diagram is given above.

SOLUTION (2.21new)

Known: The drawing in Fig. P2.20 shows the engine, transmission, and propeller shaft of a prototype automobile. The transmission and engine are not bolted together but are attached separately to the frame. The transmission weighs 50 lb, receives an engine torque of 100 lb-ft at A through a flexible coupling, and attaches to the propeller shaft at B through a universal joint. The transmission is bolted to the frame at C and D. Assume that the transmission ratio is -3; i.e., reverse gear with propeller shaft speed = -1/3 engine speed.

Find: Draw the transmission as a free body in equilibrium.

Schematic and Given Data:

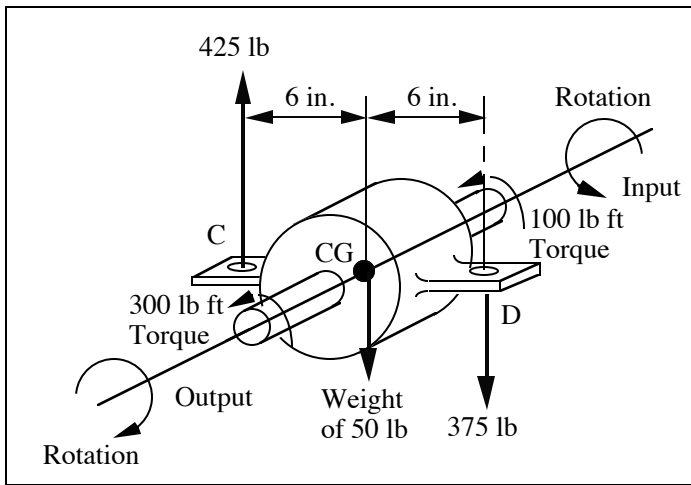

Assumption: The friction losses in the gear box are negligible.

Analysis:

1. The force on the transmission at C is 425 lb upward.
2. The force on the transmission at D is 375 lb downward.
3. A free body diagram is given above.

Comment: In textbook problem 2.20, the transmission weights only 50 lb, yet transmits a torque of 100 lb-ft during operation.

SOLUTION (2.22)

Known: An electric fan motor supported by mountings at A and B delivers a known torque to fan blades which, in turn, push air forward with a known force.

Find: Determine all loads acting on the fan and sketch it as a free-body in equilibrium.

Schematic and Given Data:

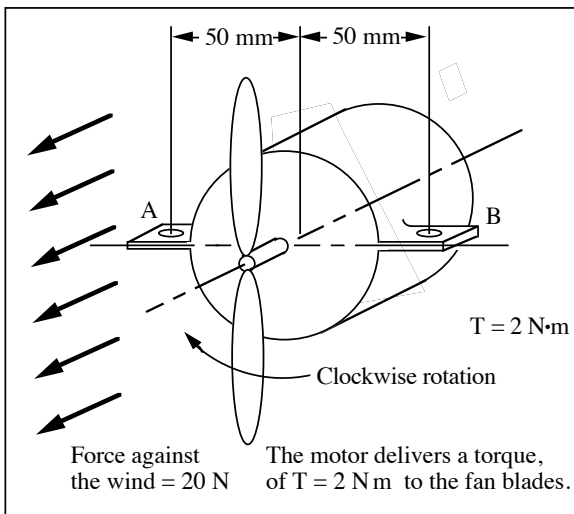

Assumption: The gravity forces can be ignored.

Analysis:

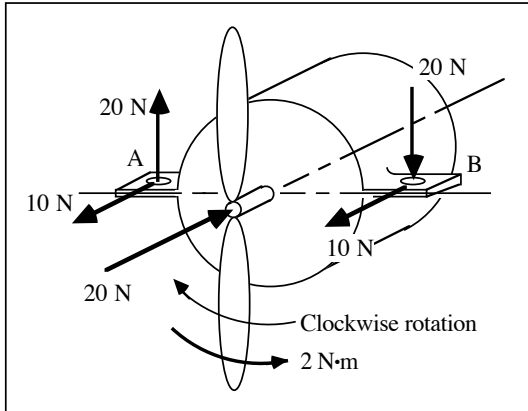

1. The torque exerted on the blades by the wind is 2 N·m counterclockwise.
2. Mounting forces = $(2 \text{ N}\cdot\text{m}) / (0.1 \text{ m}) = 20 \text{ N}$. Thus, 20 N is exerted upward at A and downward at B.

SOLUTION (2.23new)

Known: An electric fan motor supported by mountings at A and B delivers a torque of 4 N·m to fan blades which, in turn, push air forward with a force of 40 N.

Find: Determine all loads acting on the fan and sketch it as a free-body in equilibrium.

Schematic and Given Data:

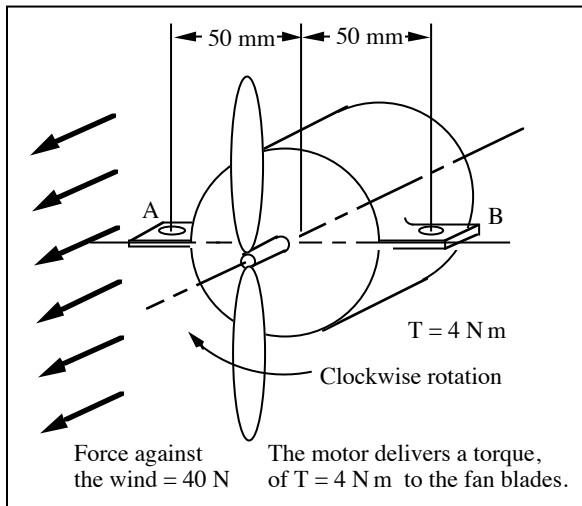

Assumption: The gravity forces can be ignored.

Analysis:

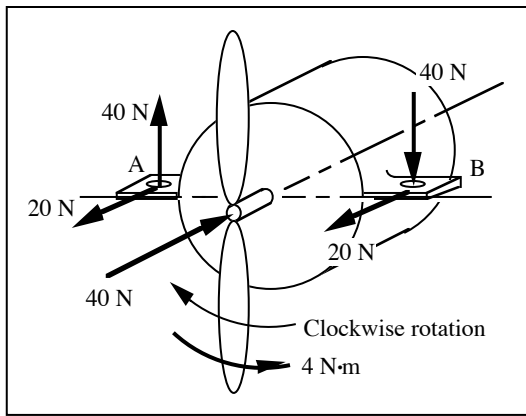

1. The torque exerted on the blades by the wind is 4 N·m counterclockwise.
2. Mounting forces = $(4 \text{ N}\cdot\text{m})/(0.1 \text{ m}) = 40 \text{ N}$. Thus, 40 N is exerted upward at A and downward at B.
3. The force on the motor mount is 40 N upward at A and 40 N downward at B.

SOLUTION (2.24)

Known: A pump is driven by a motor integrally attached to a gear reducer. Shaft C is attached to C', face A is attached to A', and face B is attached to B'.

Find: Sketch the connecting tube and show all loads acting on it.

Schematic and Given Data:

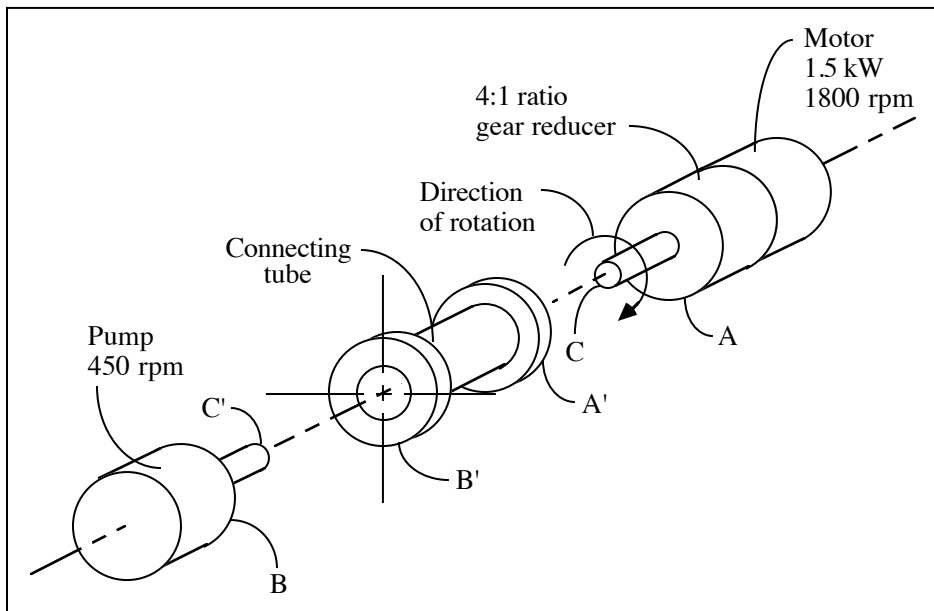

Assumption: The components are in static equilibrium.

Analysis:

1. From Eq. (1.2), motor torque, $T = \frac{9549 \cdot \dot{W}}{n} = \frac{9549(1.5)}{1800} = 7.96 \text{ N}\cdot\text{m}$
2. Reducer output torque = Pump input torque = $7.96(4) = 31.84 \text{ N}\cdot\text{m}$

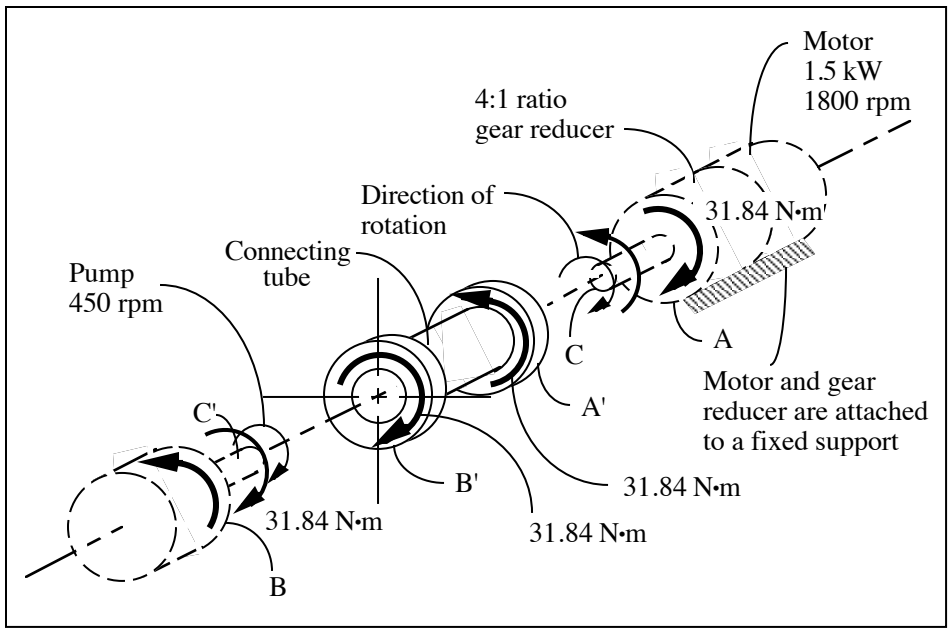

SOLUTION (2.25new)

Known: A motor integrally attached to a gear reducer drives a pump. Shaft C is attached to C', face A is attached to A', and face B is attached to B'.

Find: Calculate the output torque if the 4:1 ratio gear reducer has an efficiency of 95%.

Schematic and Given Data:

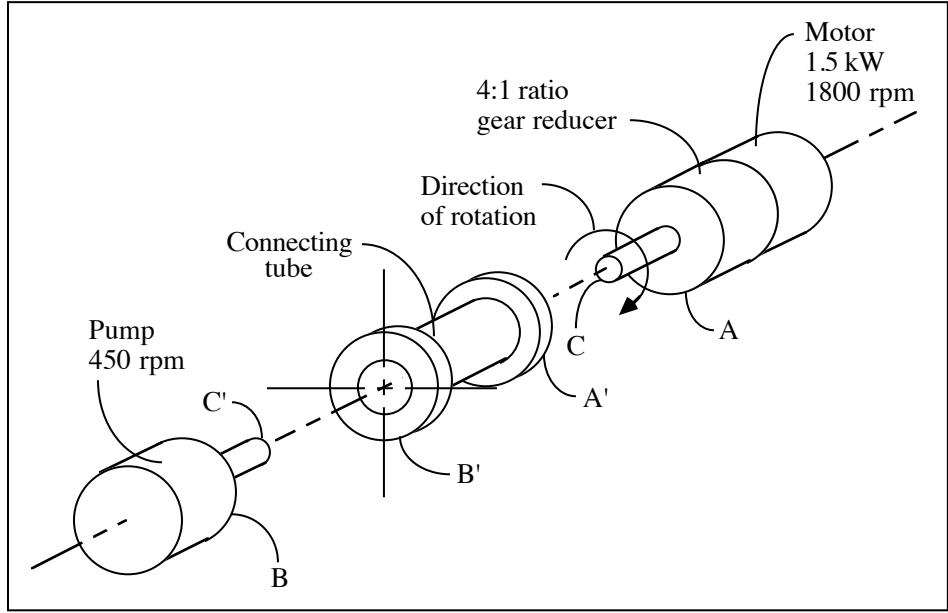

Assumption: The components are in static and thermal equilibrium.

Analysis:

1. From Eq. (1.2), motor torque, $T = \frac{9549 \cdot \dot{W}}{n} = \frac{9549(1.5)}{1800} = 7.96 \text{ N}\cdot\text{m}$

2. Reducer output torque = Pump input torque = $7.96(4) = 31.84 \text{ N}\cdot\text{m}$ for 100% efficiency.
3. $\text{efficiency} = \frac{hp_{\text{out}}}{hp_{\text{in}}} \times 100\% = 0.95 \times 100\% = 95\%$
4. $hp_{\text{out}} = T_{\text{out}} \cdot n_{\text{out}} = hp_{\text{in}} \times \text{efficiency} = 1.5 \text{ kW} \times 0.95 = 1.425 \text{ kW}$
5. Gear reducer output torque = Pump input torque = $(7.96)(4)(.95) = (.95)(31.84 \text{ N}\cdot\text{m}) = 30.25 \text{ N}\cdot\text{m}$
6. A free-body diagram is show below for the motor, gear reducer, connecting tube, and pump where the gear reducer efficiency is 95%.

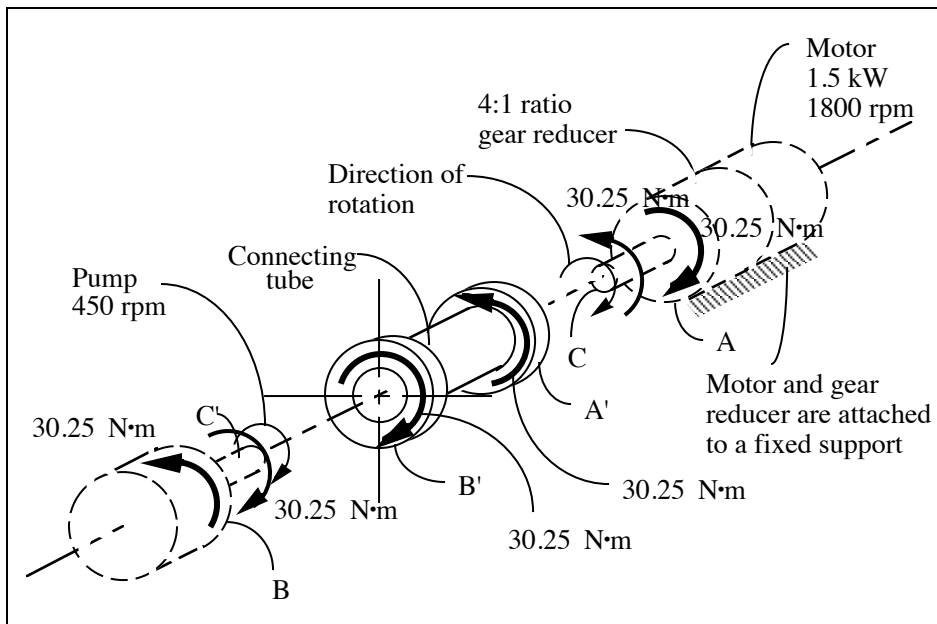

Comment: In textbook problem 2.24, the gear reducer has an efficiency of 100%.

SOLUTION (2.26)

Known: An engine and propeller rotate clockwise viewed from the propeller end. A reduction gear housing is bolted to the engine housing through the bolt holes shown. The power and angular velocity of the engine are known.

Find:

- (a) Determine the direction and magnitude of the torque applied to the engine housing by the reduction gear housing.
- (b) Determine the magnitude and direction of the torque reaction tending to rotate (roll) the aircraft.
- (c) Find an advantage of using opposite-rotating engines with twin-engine propeller-driven aircraft.

Schematic and Given Data:

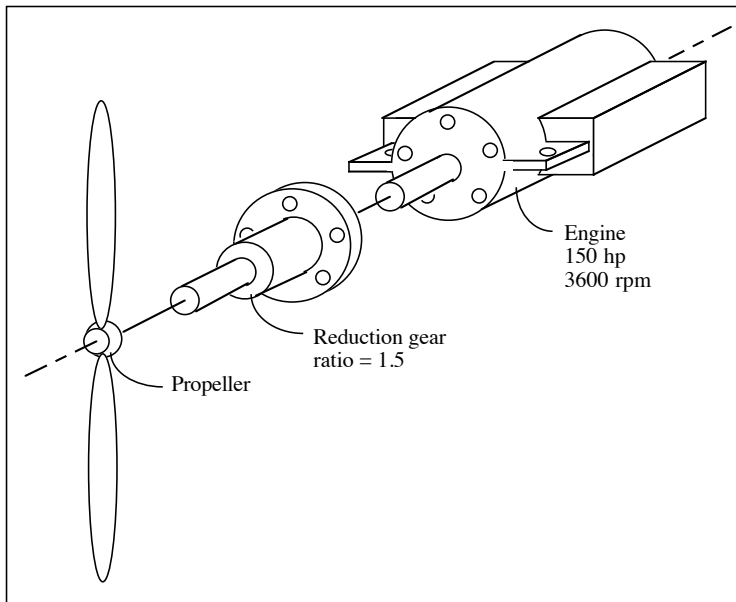

Assumption: The friction losses are negligible.

Analysis:

1. From Eq. (1.3), engine torque, $T = \frac{5252 \cdot \dot{W}}{n} = \frac{5252(150)}{3600} = 219 \text{ lb ft}$
2. Reduction gear torque, $T = 219(1.5) = 328 \text{ lb ft}$

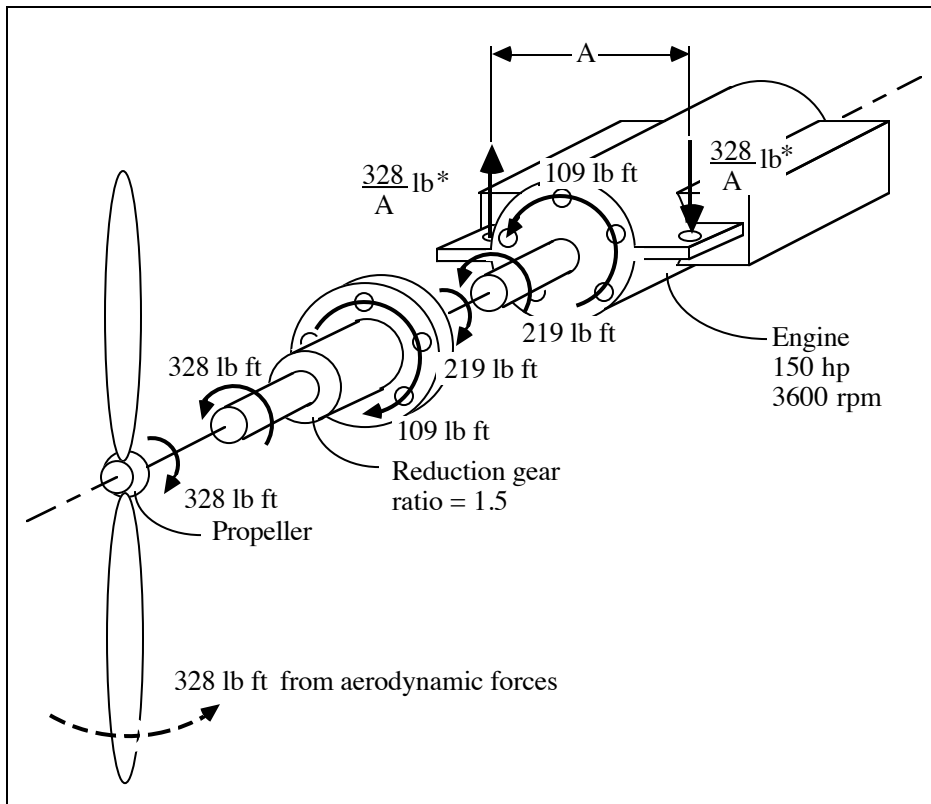

3. The attachment forces apply an equal and opposite torque of 328 lb·ft ccw tending to "roll" the airplane--see (*) in the above figure.
4. Thus, the torque applied to the engine housing by the reduction gear housing is 109 lb ft counter-clockwise, and the torque reaction tending to rotate the aircraft is 328 lb ft counter-clockwise. ■
5. Torque reactions applied to the air frame by the two engines cancel. (This produces bending in the connecting structure, but does not require a compensating roll torque from the aerodynamic control surfaces.) ■

SOLUTION (2.27)

Known: A marine engine delivers a torque of 200 lb-ft to a gearbox that provides a reverse rotation of -4:1.

Find: Determine the torque required to hold the gearbox in place.

Schematic and Given Data:

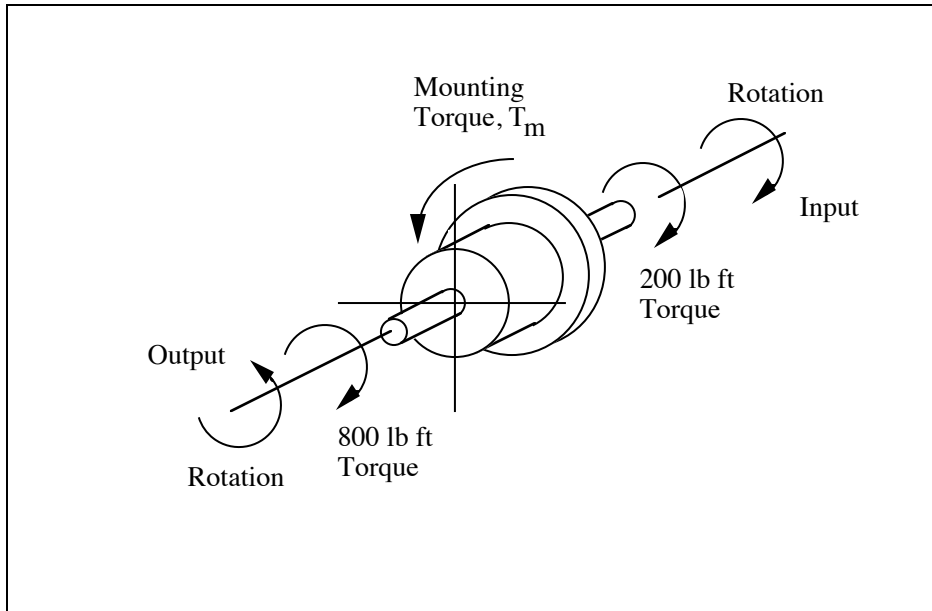

Assumption: The components are in static equilibrium.

Analysis:

1. The summation of moments about the axis of the shaft must be zero. Therefore,
 $T_{\text{output}} + T_{\text{input}} + T_{\text{mounting}} = 0$.
2. The input torque is in the same direction as the input rotation. The output torque is in a direction opposite the output rotation, and it is known that the output rotation is opposite the input rotation. Therefore the input and output torques act on the reducer shafts in the same direction.
3. Also, $T_{\text{input}} = 200 \text{ lb ft}$, $T_{\text{output}} = (4)(200 \text{ lb ft}) = 800 \text{ lb ft}$.
4. Therefore we have, $T_{\text{mounting}} = -(T_{\text{output}} + T_{\text{input}}) = -(200 + 800) = -1,000 \text{ lb ft}$.

Comment: The directions of the torques and the shaft rotations are shown in the above diagram.

SOLUTION (2.28new)

Known: A marine engine delivers a torque of 400 lb-ft to a gearbox that provides a reverse rotation of -4:1.

Find: Determine the torque required to hold the gearbox in place.

Schematic and Given Data:

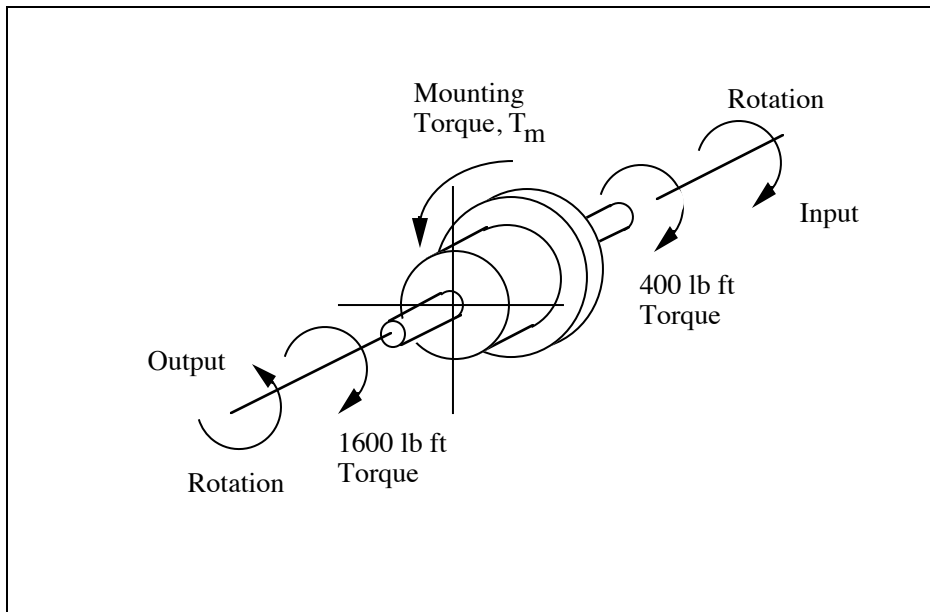

Assumption: The components are in static equilibrium.

Analysis:

1. The summation of moments about the axis of the shaft must be zero. Therefore, $T_{\text{output}} + T_{\text{input}} + T_{\text{mounting}} = 0$.
2. The input torque is in the same direction as the input rotation. The output torque is in a direction opposite the output rotation, and it is known that the output rotation is opposite the input rotation. Therefore the input and output torques act on the reducer shafts in the same direction.
3. Also, $T_{\text{input}} = 400 \text{ lb ft}$, $T_{\text{output}} = (4)(400 \text{ lb ft}) = 1600 \text{ lb ft}$.
4. Therefore we have, $T_{\text{mounting}} = -(T_{\text{output}} + T_{\text{input}}) = -(400 + 1600) = -2,000 \text{ lb ft}$.

Comment: The directions of the torques and the shaft rotations are shown in the above diagram.

SOLUTION (2.29)

Known: A motor delivers 50 lb-ft torque at 2000 rpm to an attached gear reducer. The reducer and motor housings are connected together by six bolts located on a 12-in.-dia. circle, centered about the shaft. The reducer has a 4:1 ratio. Neglect friction and weight.

Find: Estimate the average shearing force carried by each bolt.

Schematic and Given Data:

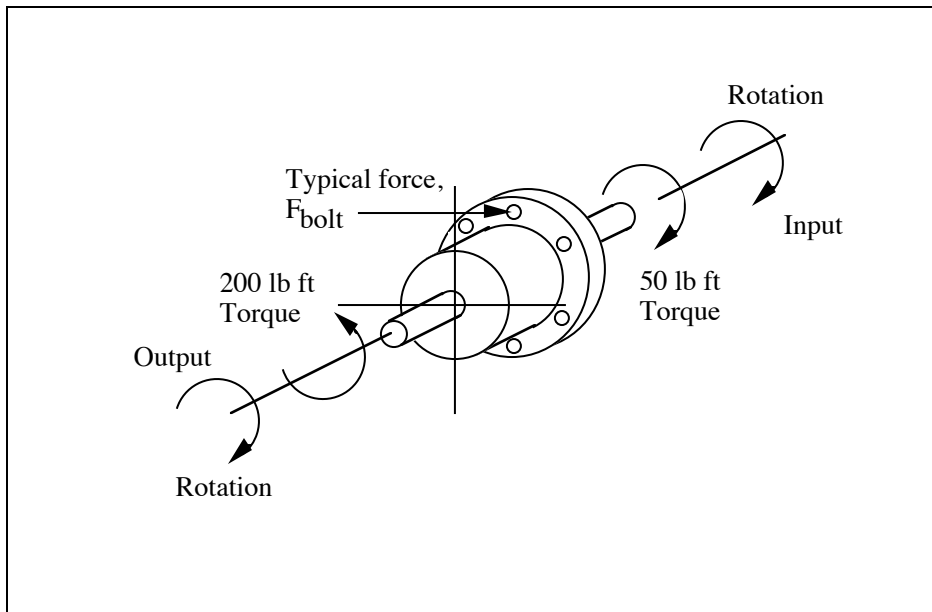

Assumption:

1. Neglect friction and weight.
2. The components are in static equilibrium.

Analysis:

1. The summation of moments about the axis of the shaft must be zero. Therefore, $T_{\text{output}} + T_{\text{input}} + T_{\text{bolts}} = 0$.
2. The input torque is in the same direction as the input rotation. The output torque is in a direction opposite the output rotation, and it is known that the output rotation is in the same direction as the input rotation. Therefore the input and output torques act on the reducer shafts in opposite directions.
3. Also, $T_{\text{input}} = 50 \text{ lb ft}$, $T_{\text{output}} = (-4)(50 \text{ lb ft}) = -200 \text{ lb ft}$.
4. Therefore we have, $T_{\text{bolts}} = -(T_{\text{output}} + T_{\text{input}}) = -(50 - 200) = +150 \text{ lb ft}$.
5. The force on each bolt, F_{bolts} can be calculated from the following equation:

$$T_{\text{bolts}} = 6 F_{\text{bolts}} r_{\text{bolt circle}} = 6 F_{\text{bolts}} (0.5 \text{ feet}) = 150 \text{ lb ft.}$$

$$\text{Yielding } F_{\text{bolts}} = 50 \text{ lb (per bolt)}$$

Comment: The directions of the torques, the shaft rotations, and the typical bolt force acting on the reducer are shown in the above diagram.

SOLUTION (2.30D)

Known: A single-cylinder reciprocating compressor has a crankshaft, connecting rod, piston, and frame. The piston is 60° before head-end dead center on the compression stroke.

Find: Sketch the crankshaft, connecting rod, piston, frame and the entire compressor as separate free bodies for the 60° condition.

Schematic and Given Data:

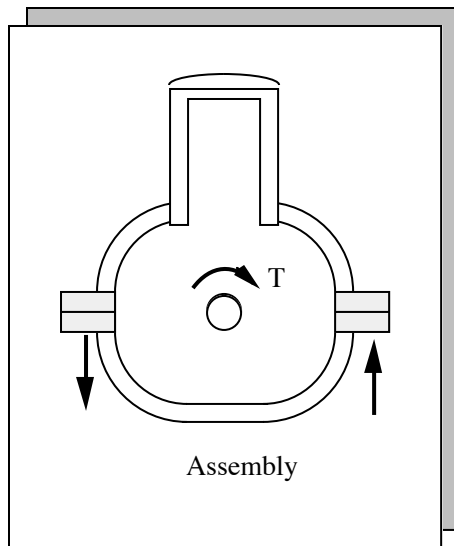

Analysis:

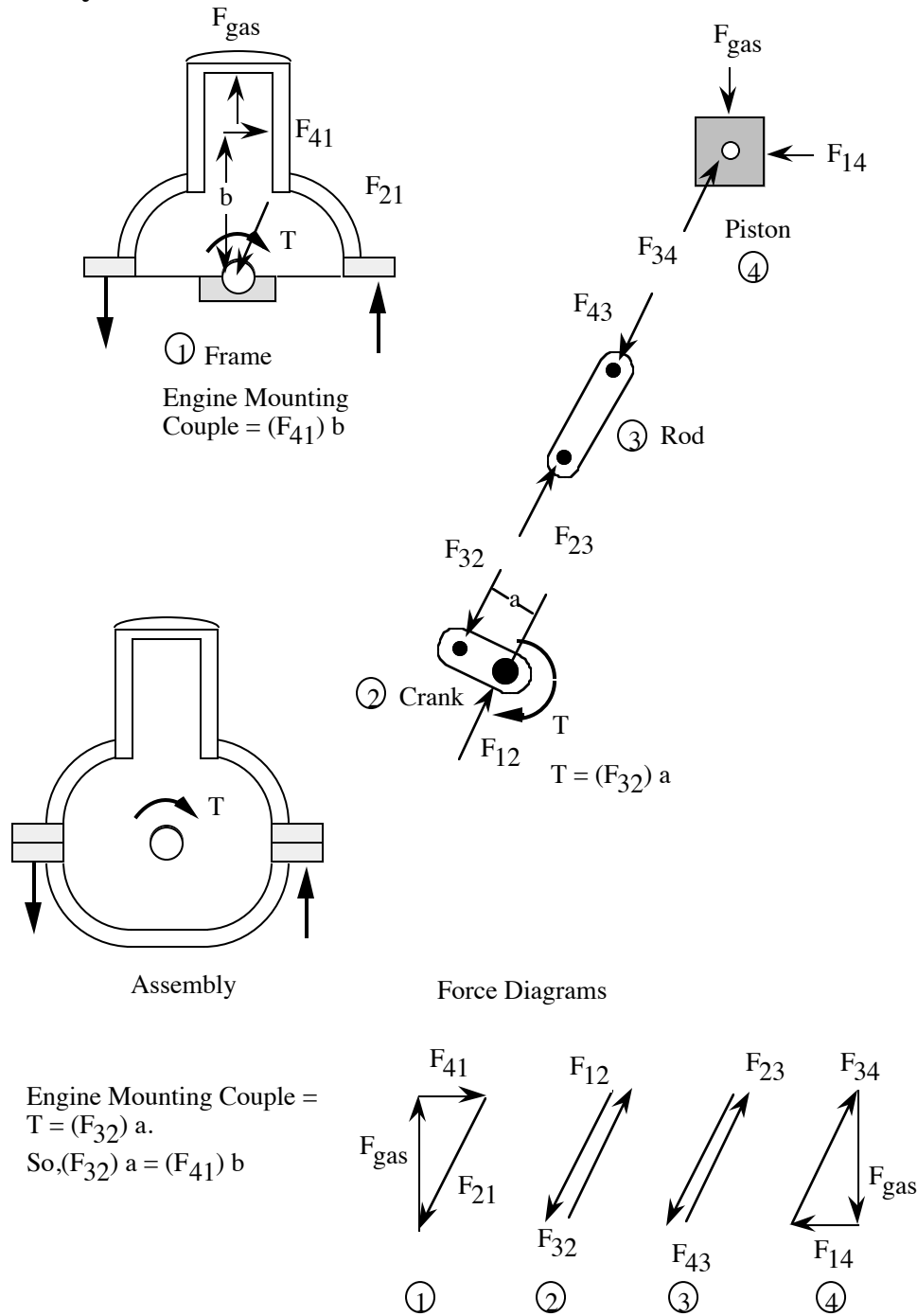

SOLUTION (2.31)

Known: A gear reduction unit and a propeller of an outboard boat operate with a known motor torque and a known thrust.

Find: Show all external loads acting on the assembly.

Schematic and Given Data:

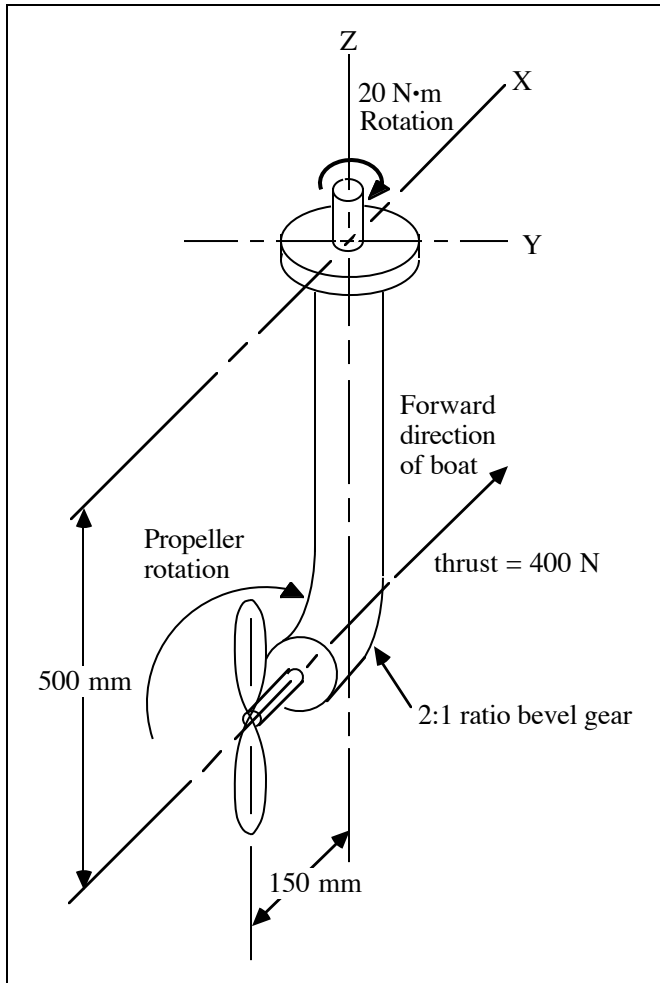

Assumption: The effects of gravity and friction are negligible.

Analysis:

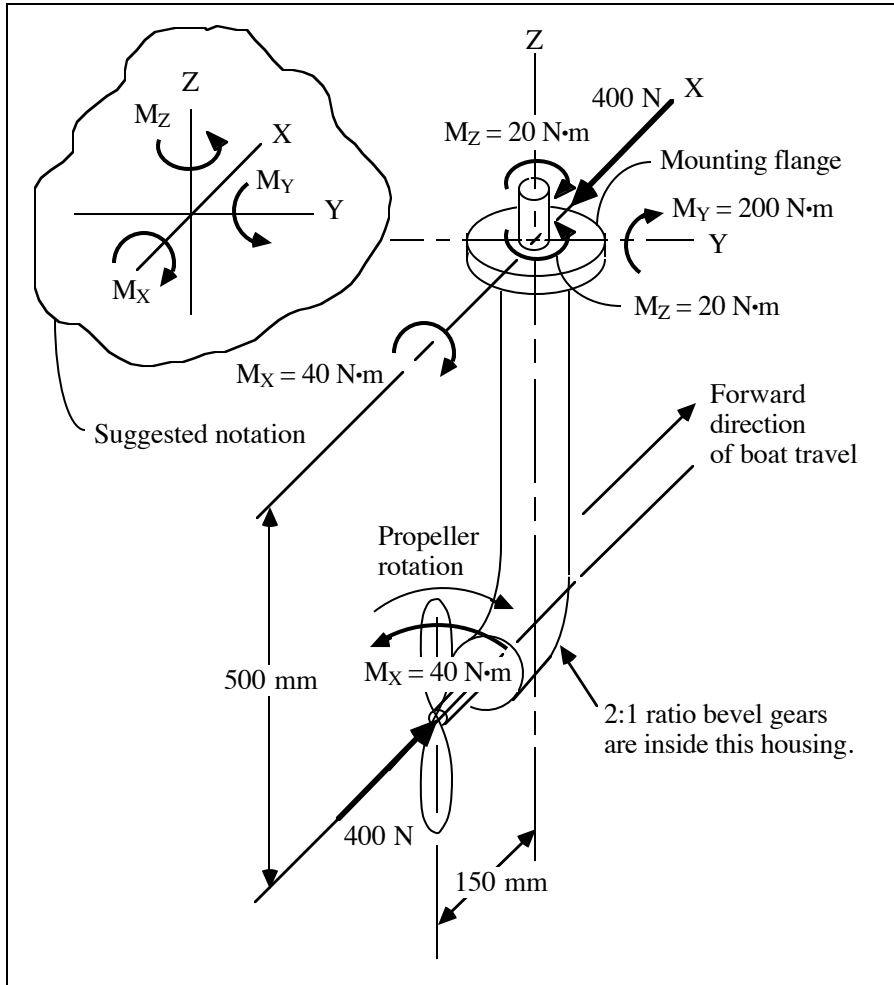

SOLUTION (2.32)

Known: A rider is applying full weight to one pedal of a bicycle.

Find: Draw as free-bodies in equilibrium:

- (a) The pedal, crank, and pedal sprocket assembly.
- (b) The rear wheel and sprocket assembly.
- (c) The front wheel.
- (d) The entire bicycle and rider assembly.

Schematic and Given Data:

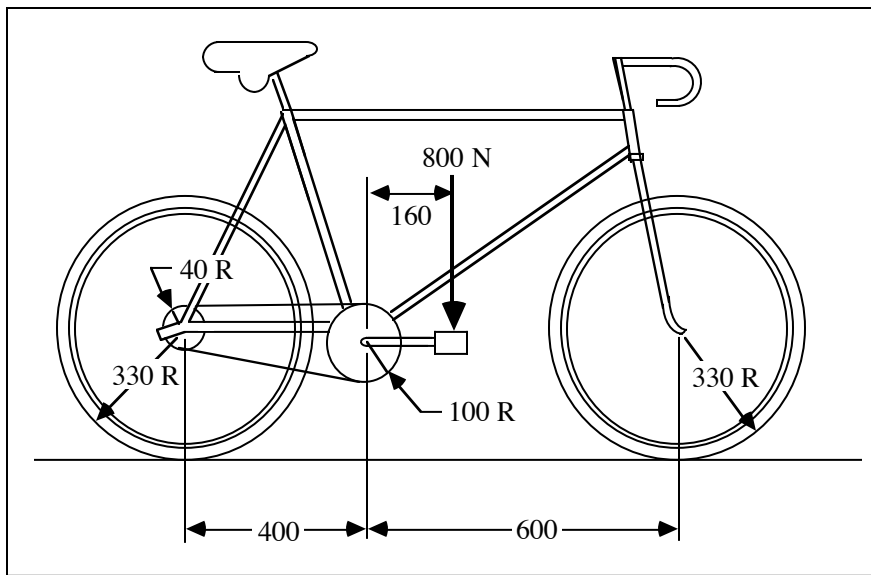

Assumptions:

- 1. The bicycle can be treated as a two-dimensional machine.
- 2. The bicycle weight is negligible.

Analysis:

- 1. For the pedal, crank, and pedal sprocket assembly, the chain force is $F = 800(160/100) = 1280 \text{ N}$

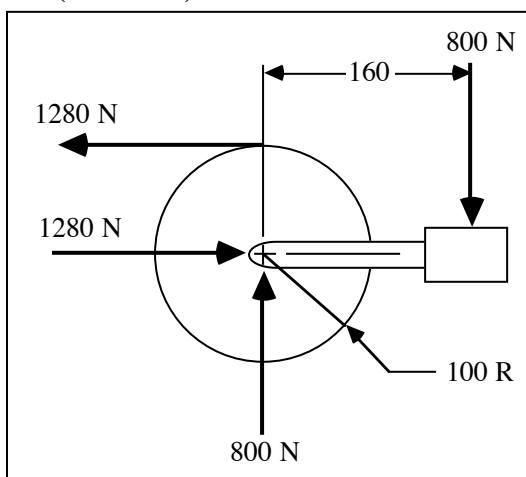

- 2. For the rear wheel and sprocket assembly, rear wheel gravity load = $800(440/1000) = 352 \text{ N}$

rear wheel friction force = $1280(40/330) = 155.2 \text{ N}$
 horizontal bearing force = $1280 + 155.2 = 1435.2 \text{ N}$

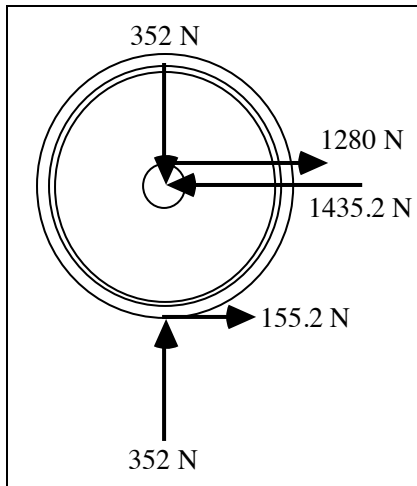

3. For the front wheel, front wheel gravity load = $800(560/1000) = 448 \text{ N}$

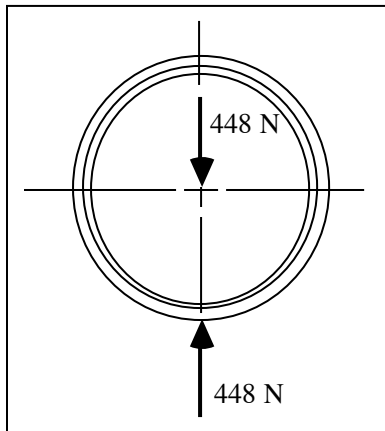

4. For the entire bicycle and rider assembly, the drawing is given below.

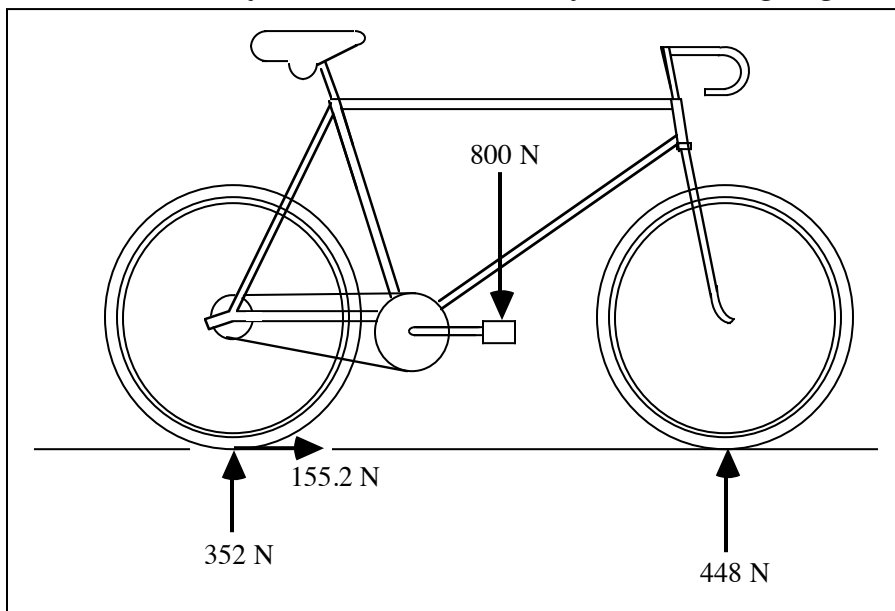

Comments: The drawing does not show the rearward 155.2 N inertia force necessary to establish $\sum F_H = 0$. It would be located thru the center of gravity of the cycle-plus-rider, the location of which is not given. Since this vector would be at some distance "h" above the ground, the resulting counter clockwise couple, 155.2 h, would be balanced by decreasing the vertical force on the front wheel and increasing the vertical force on the rear wheel, both by $(155.2 h/1000)$ N.

SOLUTION (2.33new)

Known: A small rider is applying full weight to one pedal of a bicycle.

Find: Draw as free-bodies in equilibrium:

- (a) The pedal, crank, and pedal sprocket assembly.
- (b) The rear wheel and sprocket assembly.
- (c) The front wheel.
- (d) The entire bicycle and rider assembly.

Schematic and Given Data:

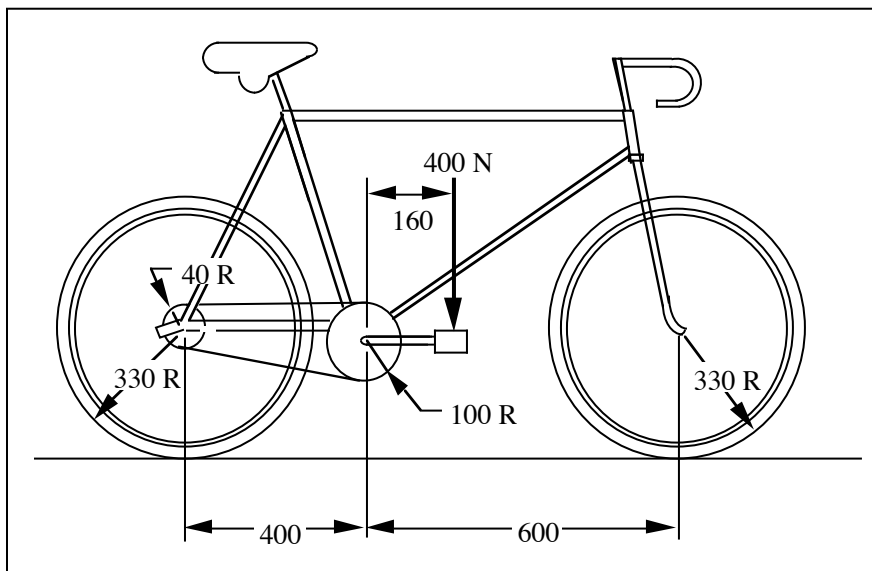

Assumptions:

1. The bicycle can be treated as a two-dimensional machine.
2. The bicycle weight is negligible.

Analysis:

1. For the pedal, crank, and pedal sprocket assembly, the chain force is $F = 400(160/100) = 640$ N

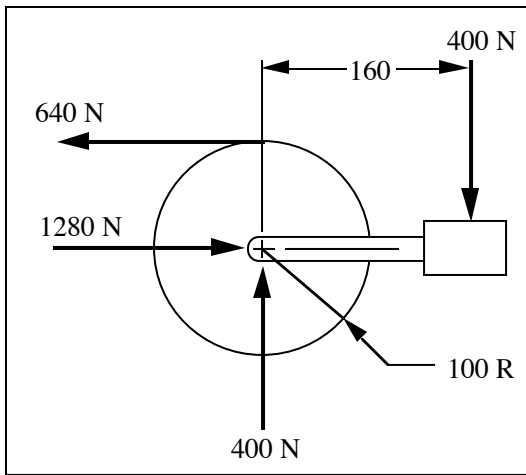

2. For the rear wheel and sprocket assembly,
 rear wheel gravity load = $400(440/1000) = 176 \text{ N}$
 rear wheel friction force = $640(40/330) = 77.5 \text{ N}$
 horizontal bearing force = $640 + 77.5 = 717.5 \text{ N}$

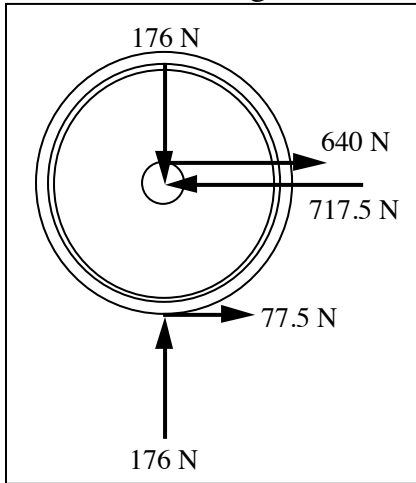

3. For the front wheel, front wheel gravity load = $400(560/1000) = 224 \text{ N}$

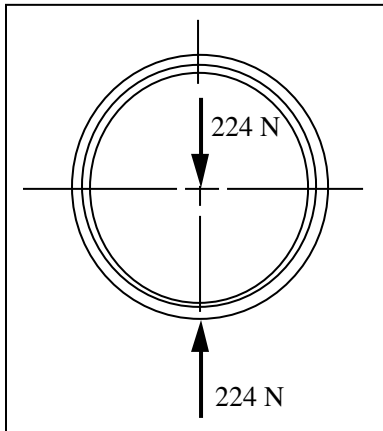

4. For the entire bicycle and rider assembly, the drawing is given below.

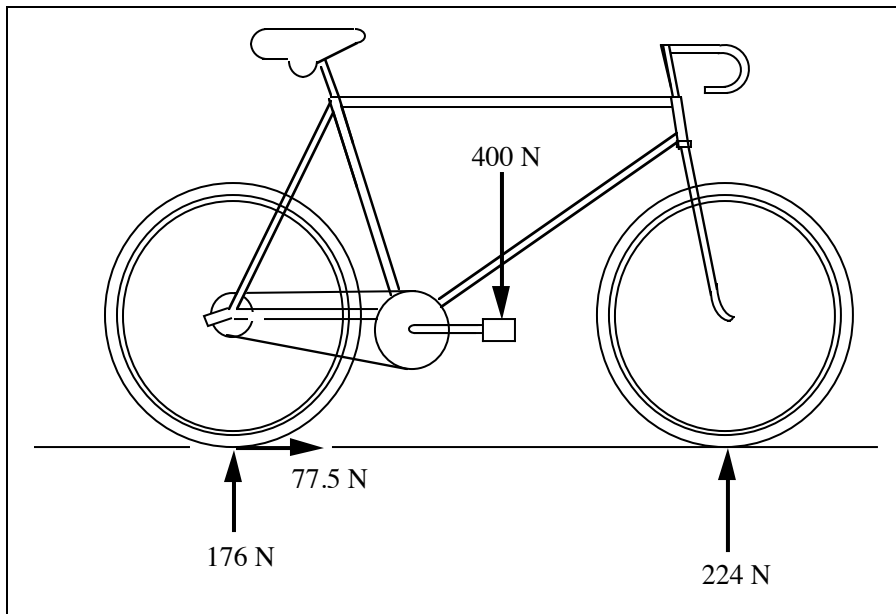

Comments: The drawing does not show the rearward 77.5 N inertia force necessary to establish $\sum F_H = 0$. It would be located thru the center of gravity of the cycle-plus-rider, the location of which is not given. Since this vector would be at some distance "h" above the ground, the resulting counter clockwise couple, 77.5 h, would be balanced by decreasing the vertical force on the front wheel and increasing the vertical force on the rear wheel, both by $(77.5 h / 1000)$ N.

SOLUTION (2.34)

Known: A solid continuous round bar is shown in Fig. P2.34 and can be viewed as comprised of a straight segment and a curved segment – segments 1 and 2. We are to neglect the weight of the member.

Find: Draw free body diagrams for segments 1 and 2. Also, calculate the force and moments acting on the ends of both segments.

Schematic and Given Data:

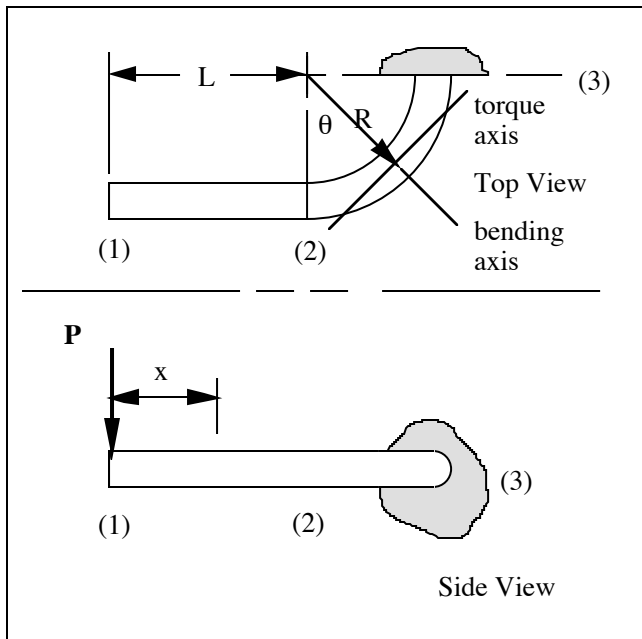

Assumption: The weight of the round bar is negligible.

Analysis:

1. For section 1 to 2, $M = Px$
2. For section 2 to 3, $M = P(L \cos \theta + R \sin \theta)$ and $T = P[L \sin \theta + R(1 - \cos \theta)]$.

SOLUTION (2.35)

Known: The spring clip shown in Fig. P2.35 has a force P acting on the free end. We are to neglect the weight of the clip.

Find: Draw free-body diagrams for segments 1 and 2 – straight and curved portions of the clip. Also, determine the force and moments acting on the ends of both segments.

Schematic and Given Data:

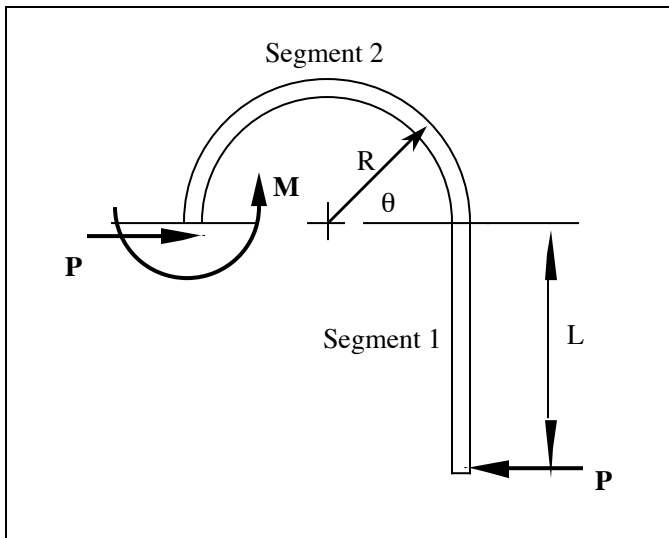

Assumption: The weight of the clip is negligible.

Analysis:

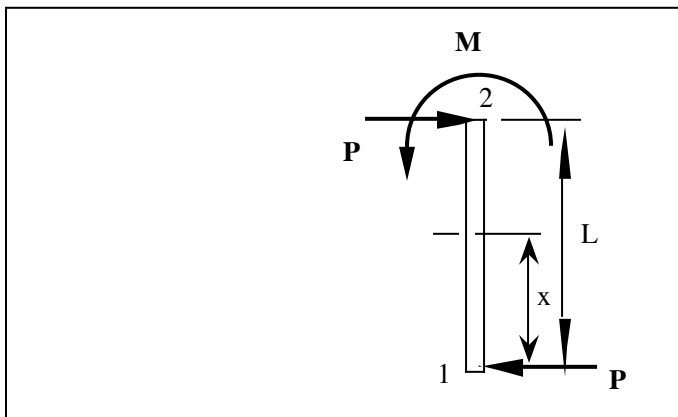
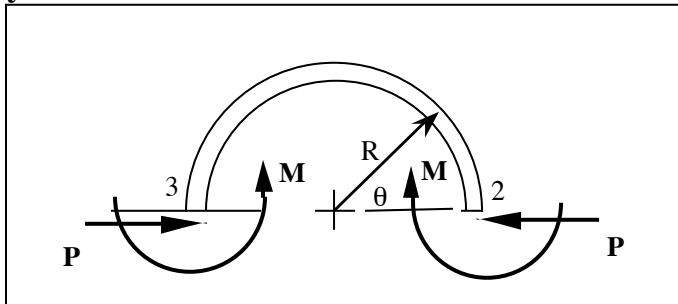

1. In the straight section 1 to 2, $M = Px$, and the shear force $V = P$. At section 2, $M = PL$.
2. In the curved section 2 to 3, $M = P(L + R \sin \theta)$. The shear force $V = P$ and the moment $M = PL$ at section 2 and at section 3.

Comment: Note that at the top of the curved section the member is in axial compression.

SOLUTION (2.36)

Known: A semicircular bar of rectangular cross section has one pinned end -- see Fig. P2.36. The free end is loaded as shown.

Find: Draw free-body diagrams for the entire semicircular bar and for a left portion of the bar. Discuss what influence the weight of the semicircular bar has on this problem.

Schematic and Given Data:

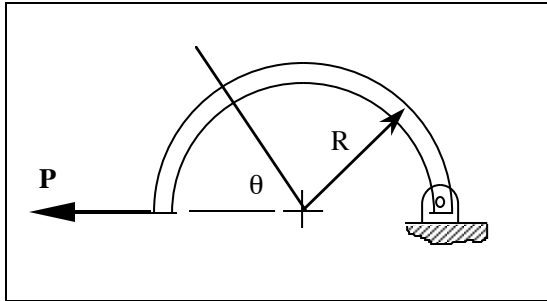

Assumptions:

1. Deflections are negligible.
2. The friction forces at the pinned end are negligible.
3. The semicircular bar is in static equilibrium.
4. The weight of the semicircular bar is negligible except where we address the effect of weight, then the force of gravity is the only body force.

Analysis:

1. A free body diagram for the entire member is shown below (ignoring the weight of the bar).

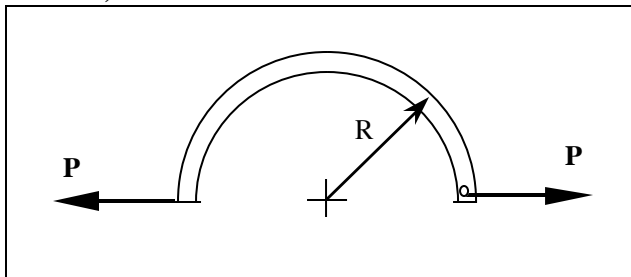

2. A free body diagram for a left portion of the member is shown below.

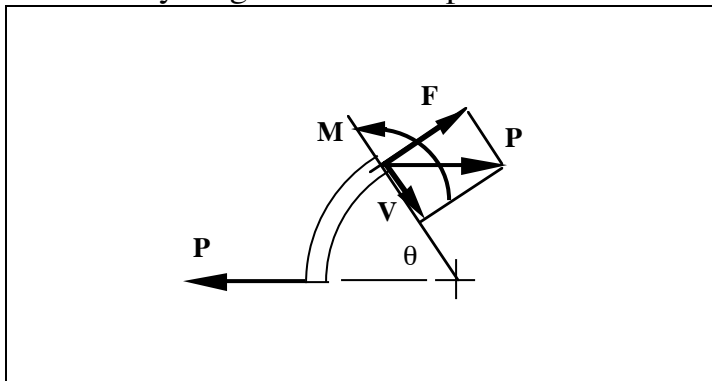

3. At any section, θ , the loads are $M = PR \sin\theta$, $F = P \sin\theta$, and $V = P \cos\theta$.

Comments: The weight for each small segment can be added in the free body diagram at the segment center of mass. An application of the equations of force equilibrium will establish the forces F , V and P , and the moment M at section θ .

SOLUTION (2.37)

Known: A bevel gear reducer with known input and output angular velocity is driven by a motor delivering a known torque of $12 \text{ N}\cdot\text{m}$. The reducer housing is held in place by vertical forces applied at mountings A, B, C and D.

Find: Determine the forces applied to the reducer at each of the mountings:

- (a) Assuming 100% reducer efficiency.
- (b) Assuming 95% reducer efficiency.

Schematic and Given Data:

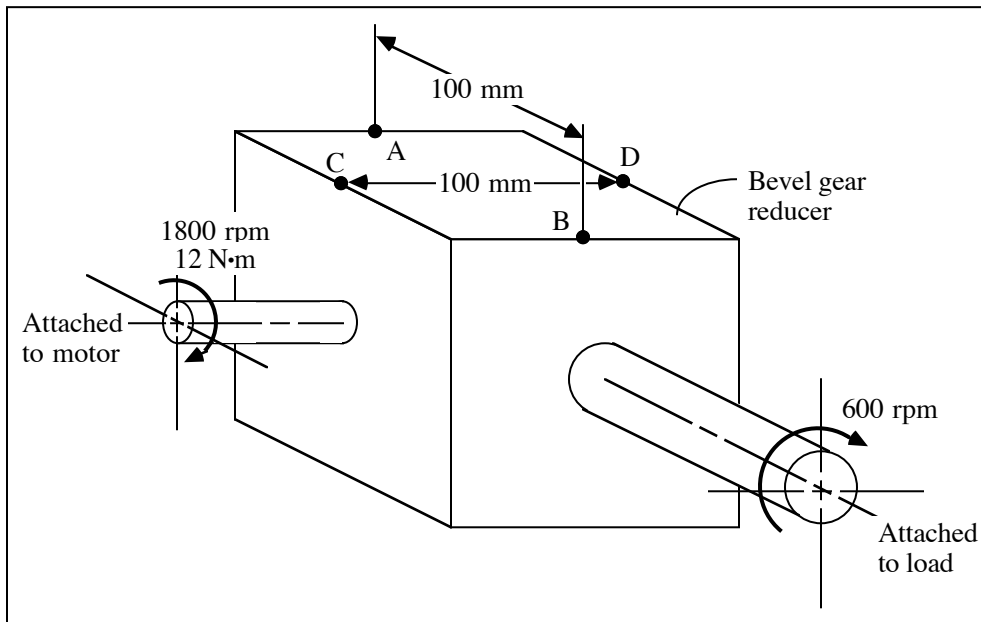

Assumption: The bevel gear reducer is in static equilibrium.

Analysis:

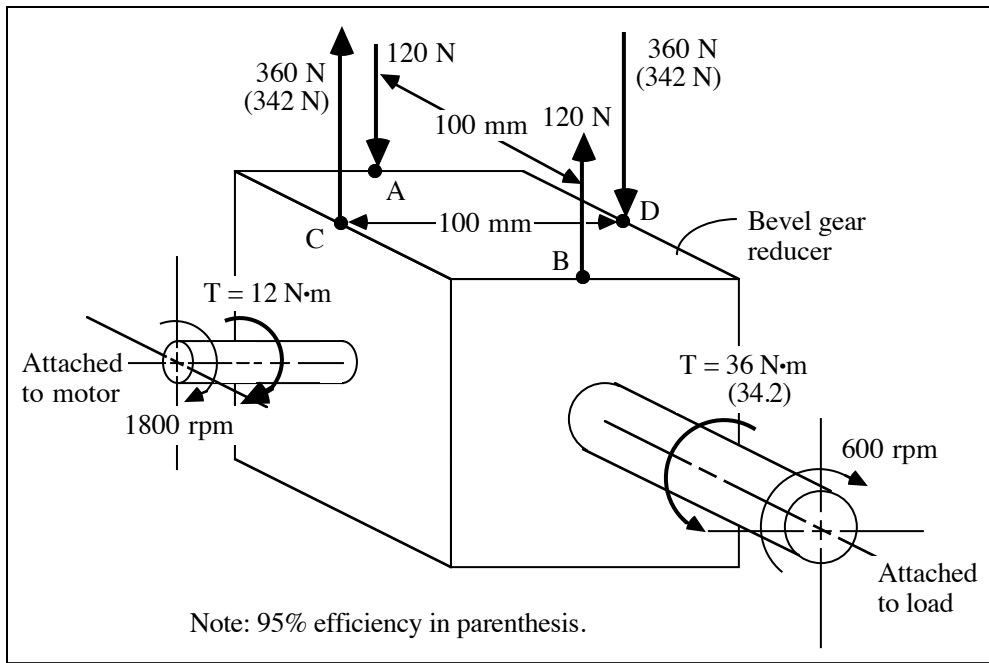

1

SOLUTION (2.38new)

Known: A bevel gear reducer with known input and output angular velocity is driven by a motor delivering a known torque of $24 \text{ N}\cdot\text{m}$. The reducer housing is held in place by vertical forces applied at mountings A, B, C and D.

Find: Determine the forces applied to the reducer at each of the mountings:

- (a) Assuming 100% reducer efficiency.
- (b) Assuming 95% reducer efficiency.

Schematic and Given Data:

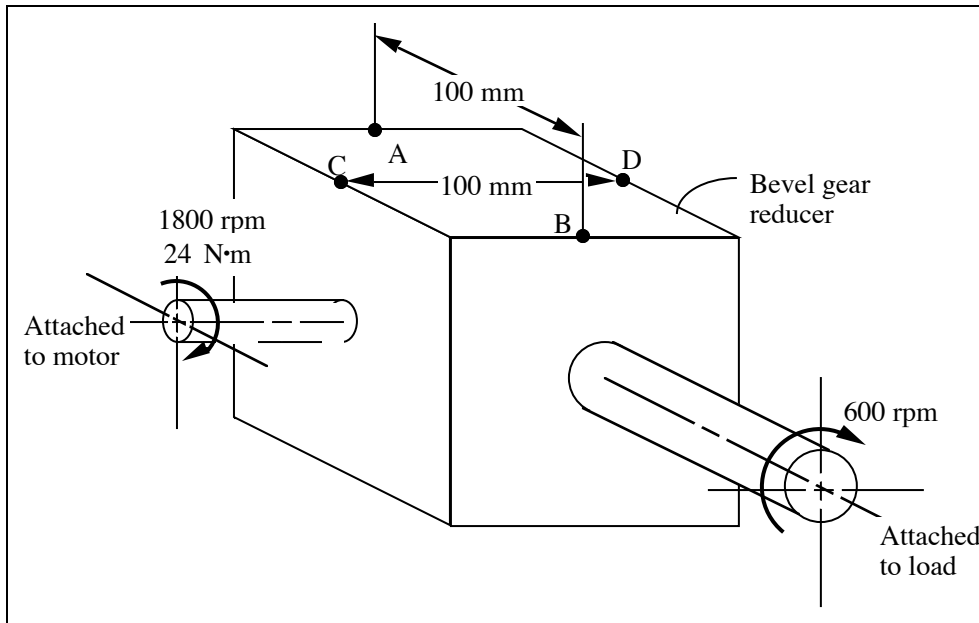

Assumption: The bevel gear reducer is in static equilibrium.

Analysis:

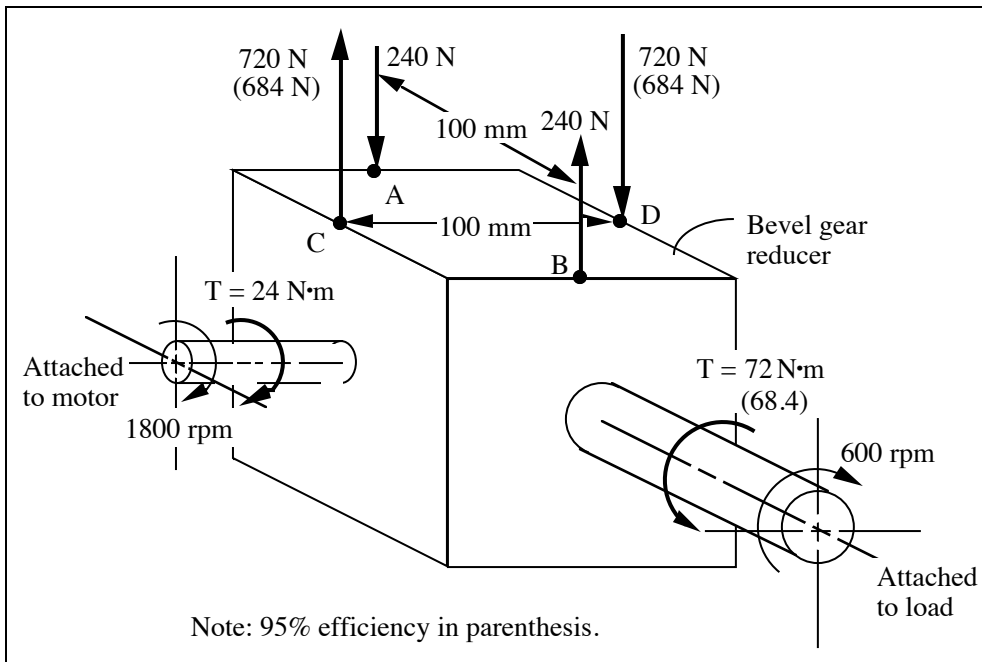

SOLUTION (2.39new)

Known: A bevel gear reducer with known input and output angular velocity is driven by a motor delivering a known torque of $12 \text{ N}\cdot\text{m}$. The reducer housing is held in place by vertical forces applied at mountings A, B, C and D. Note that $AB = CD = 50 \text{ mm}$.

Find: Determine the forces applied to the reducer at each of the mountings:

- (a) Assuming 100% reducer efficiency.
- (b) Assuming 95% reducer efficiency.

Schematic and Given Data:

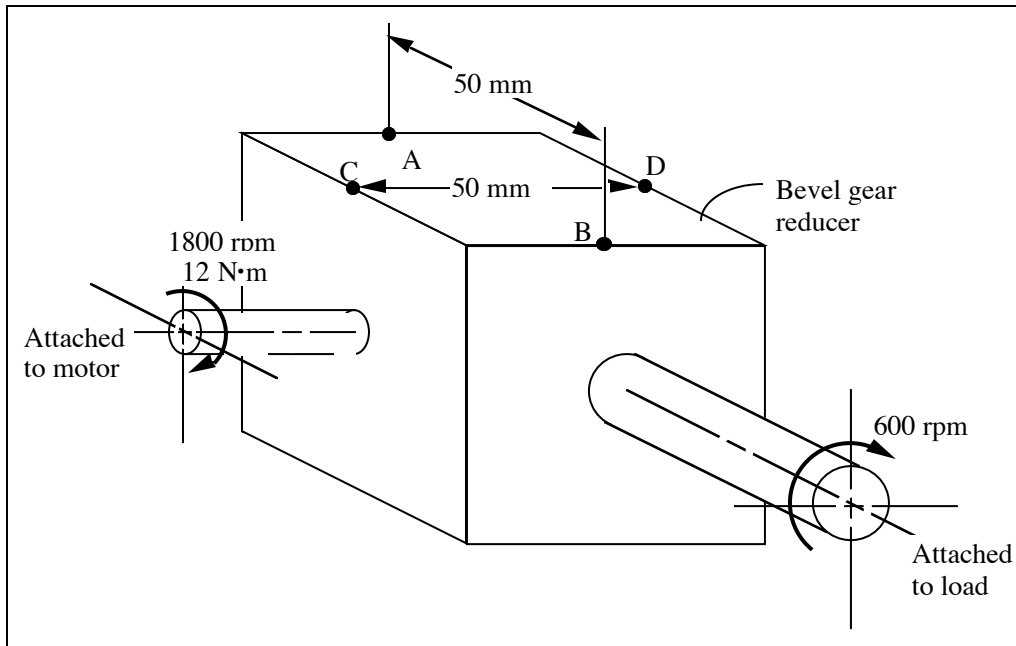

Assumption: The bevel gear reducer is in static equilibrium.

Analysis:

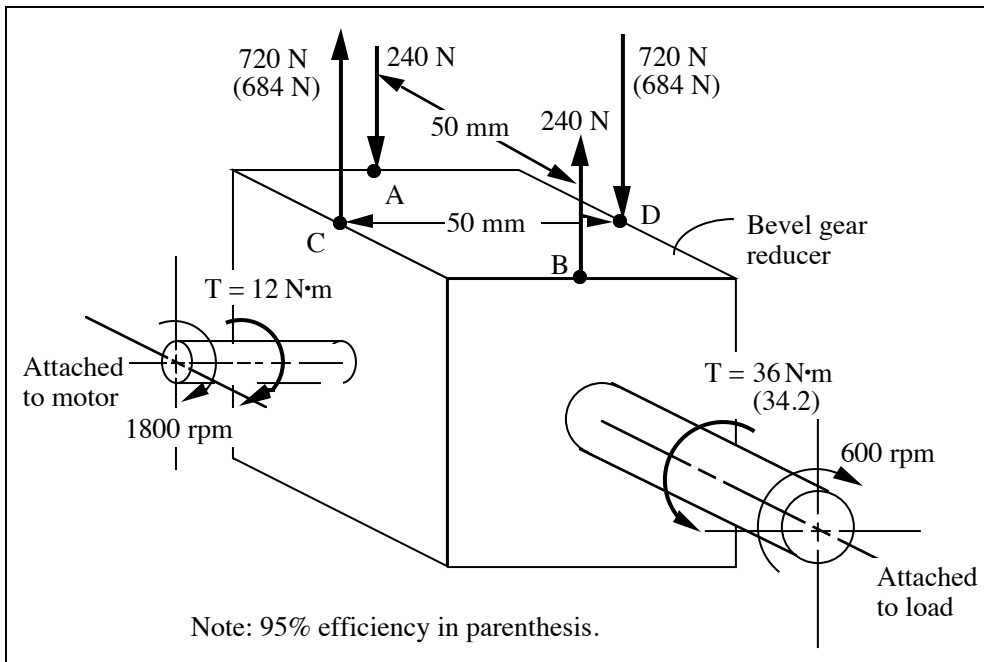

SOLUTION (2.40)

Known: A motor applies a known torque to the pinion shaft of a spur gear reducer.

Find: Sketch free-bodies in equilibrium for

- (a) The pinion and shaft assembly.
- (b) The gear and shaft assembly.
- (c) The housing.
- (d) The entire reducer assembly.

Schematic and Given Data:

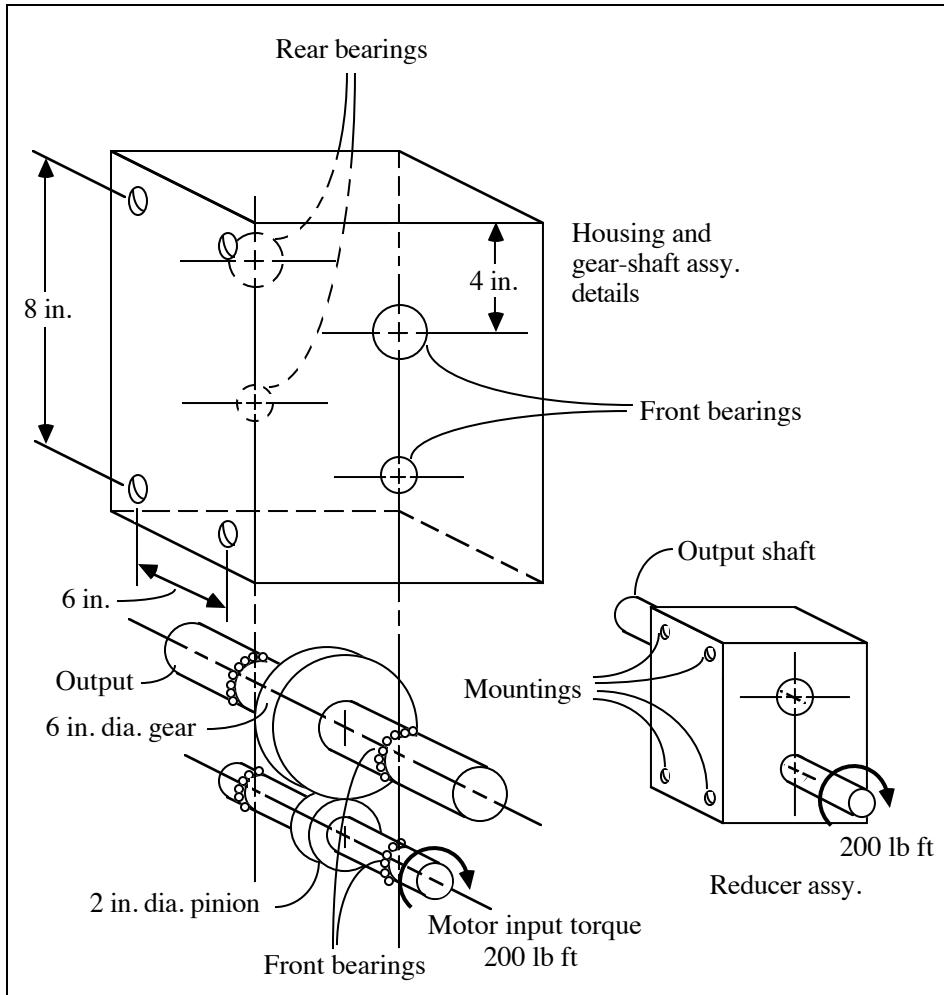

Assumptions:

- 1. The effect of gravity is negligible.
- 2. The forces between the gears act tangentially.

Analysis:

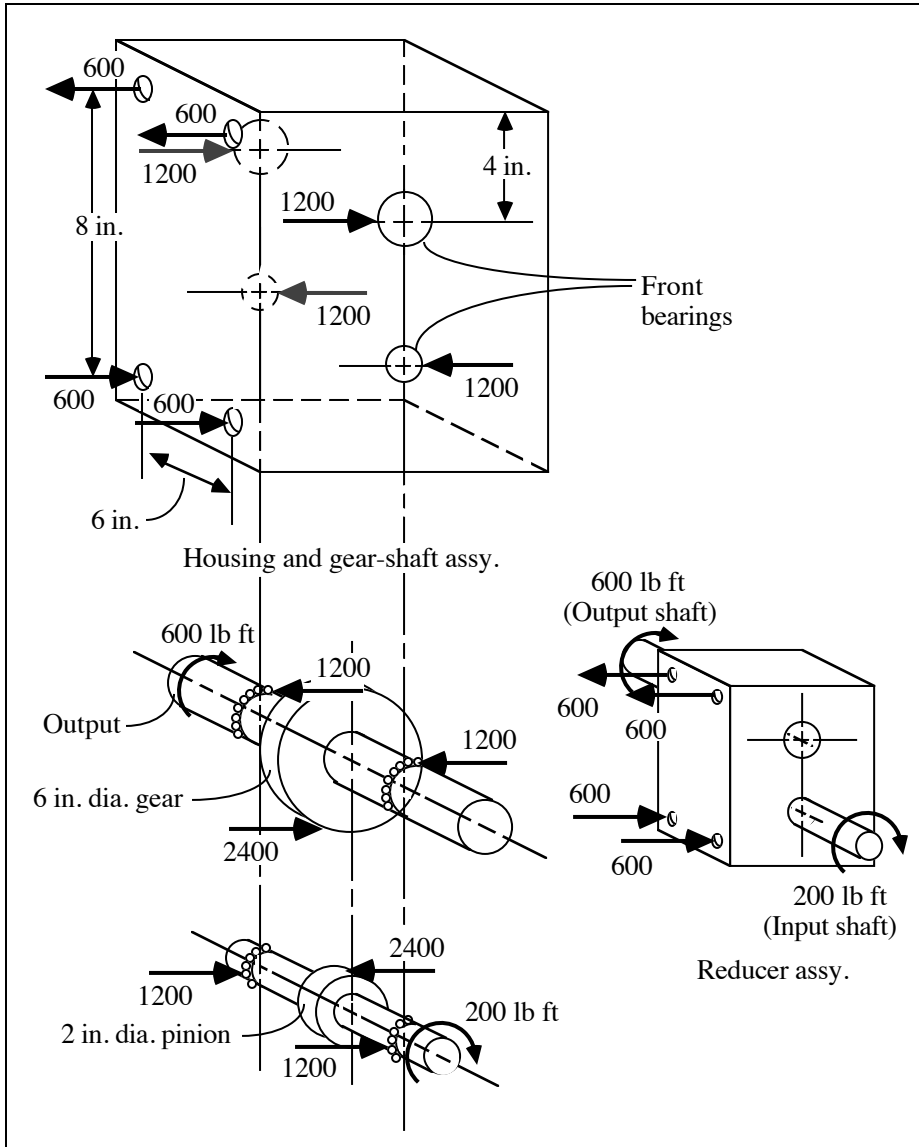

SOLUTION (2.41new)

Given: A rim and hub are connected by spokes (springs) as shown in Figure P2.41. The spokes are each tightened to a tension of 20 lb.

Find: Draw a free body diagram of (a) the hub, (b) the rim, (c) one spring, and (d) one-half (180°) of the rim.

Schematic and Given Data: See Figure P2.41.

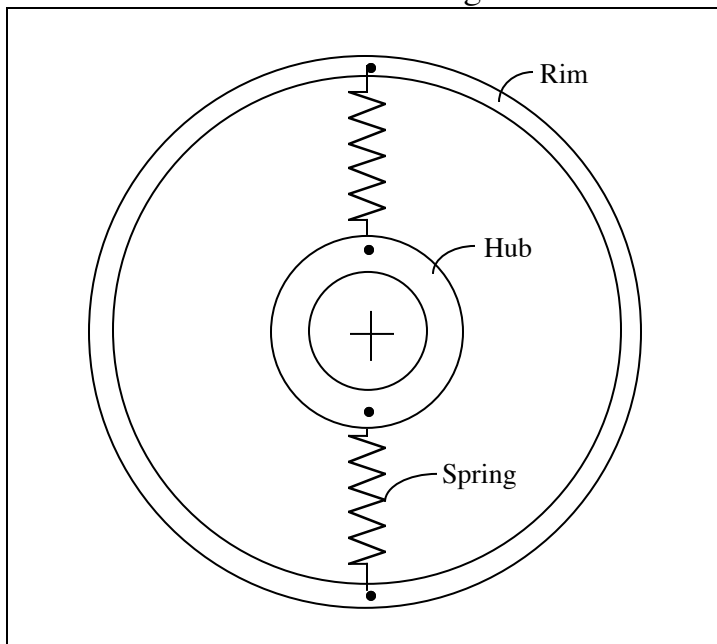

Assumption:

1. The weight of each component can be ignored.
2. The rim and hub change from circular shapes to oval shapes when the spokes are tightened.
3. The rim and hub are of homogeneous material that has the same modulus of elasticity in tension and compression.
4. The cross section of the rim and hub are each uniform.
5. The maximum stress does not exceed the proportional limit.

Analysis:

1. The hub has two opposed radial 20 lb forces pulling it apart.
2. The ring had two opposed radial 20 lb forces pulling inward.
3. Each spring has a 20 lb force on each end placing the spring in tension.
4. A free body diagram of half (180°) of the rim shows a 20 lb force pulling radially inward and a compressive force of 10 lb acting on each “cut” end of the half (180°) ring. At each cut end we show unknown moment M and shear force V .

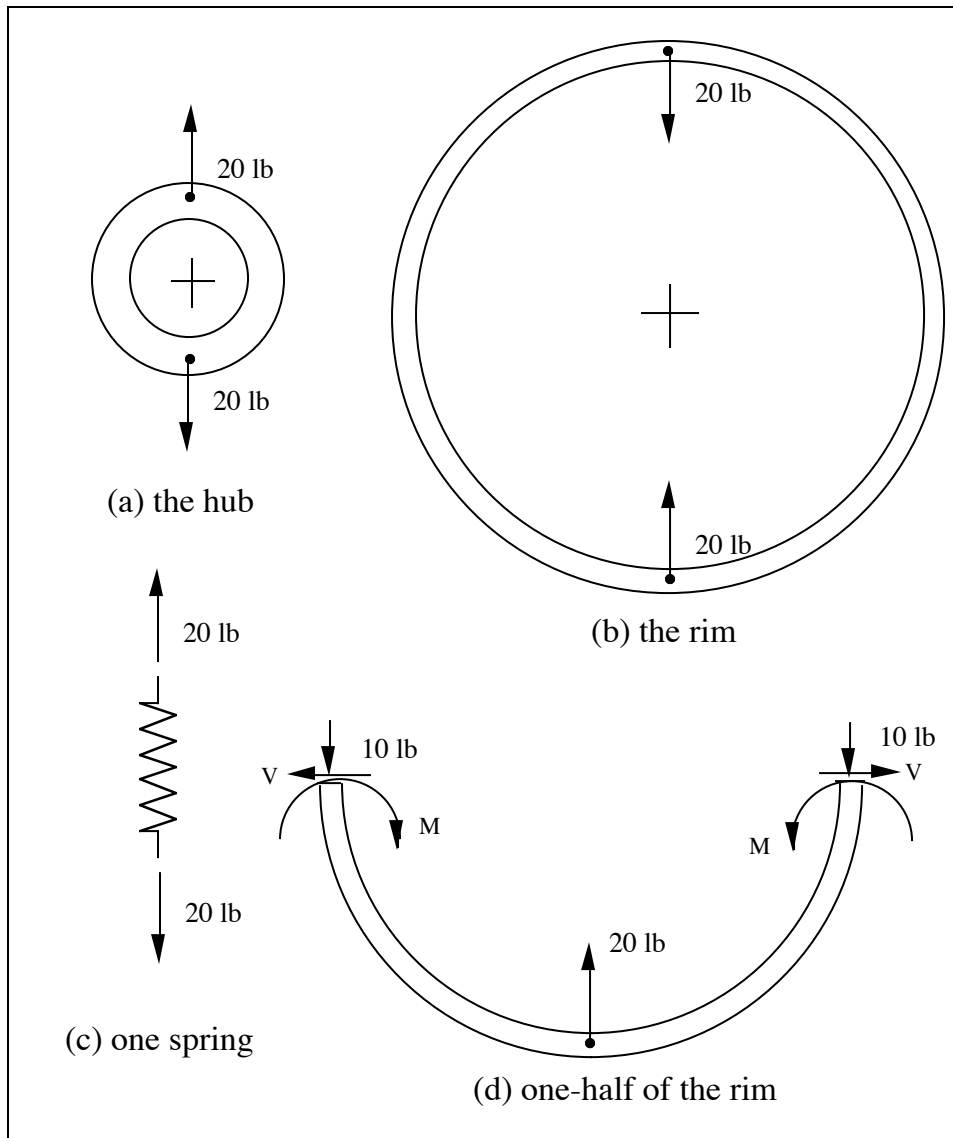

Comments:

1. The circular ring may be regarded as a statically indeterminate beam, and can be analyzed by Castigliano's method – see Section 5.8 and 5.9 of the textbook. Section 5.9 discusses the case of redundant reactions -- a statically indeterminate problem.
2. The compressive force in the ring is given by $F = -\frac{1}{2} W \sin \theta$, where W is the force in the spring (the inward force exerted by the spring on the ring), and where θ is defined in the figure below. The shear force in the ring is given by $V = -\frac{1}{2} W \cos \theta$. See the figure below for terminology.

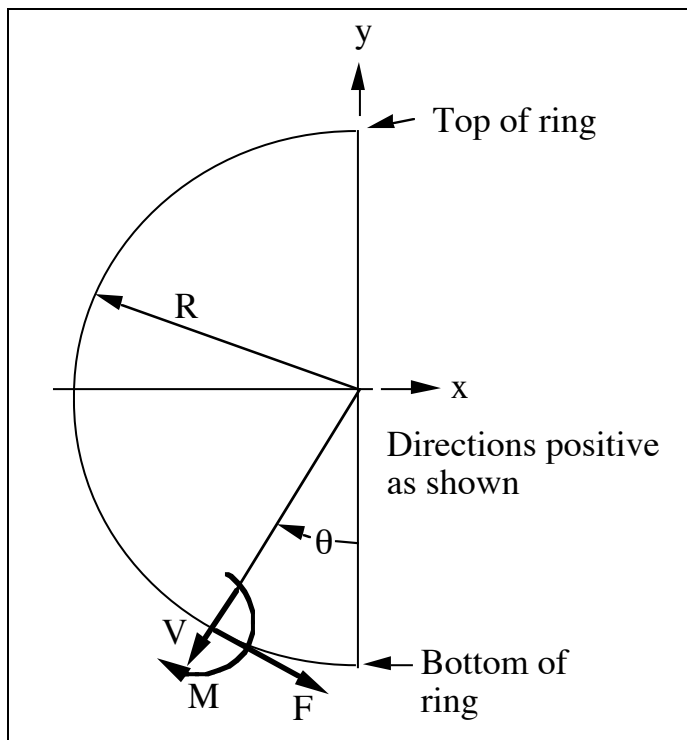

3. Roark, Formulas for Stress and Strain, gives the following equations obtained apparently by using Castigliano's method:

$$M = WR(0.3183 - \frac{1}{2} \sin \theta) = WR(0.3183 - [1/(2 \sin \theta)])$$

$$\delta_x = + 0.137 WR^3/EI \text{ (increase in diameter in the x-direction)}$$

$$\delta_y = - 0.149 WR^3/EI \text{ (decrease in diameter in the y-direction)}$$

4. In the above equations, W = inward force of the spring on the ring, I = moment of inertia of ring cross section, E = modulus of elasticity, M = bending moment, F = circumferential tension, V = radial shear at an angular distance θ from the bottom of the ring, δ_x = change in horizontal diameter, and δ_y = change in vertical diameter.

5. Note that:

$$\max (+M) = 0.3183WR \text{ at bottom and top } (\theta = 0, \theta = 180)$$

$$\max (-M) = - 0.1817WR \text{ at sides } (\theta = \pi/2, \theta = -\pi/2)$$

$$F \text{ (at bottom and top)} = 0$$

$$V \text{ (at bottom and top)} = - \frac{1}{2} W$$

6. If the ring is connected to the hub by N spokes rather than with two spokes, Roark points out that the formulas can be combined by superposition so as to cover almost any condition of loading and support likely to occur.

SOLUTION SOLUTION (2.42)

Known: An engine rotates with a known angular velocity and delivers a known torque to a transmission which drives a front and rear axle.

Find: Determine the forces applied to the free-body at A, B, C, and D.

Schematic and Given Data:

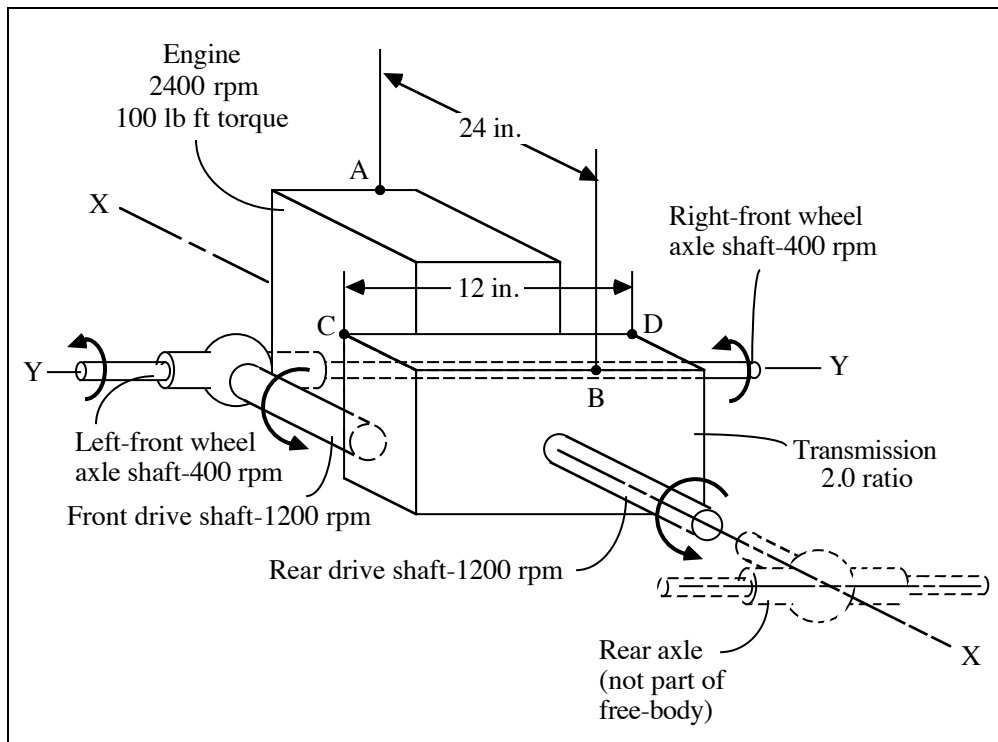

Assumptions:

1. The friction and gravity forces are negligible.
2. The mountings exert only vertical forces.
3. All four wheels have full traction.

Analysis:

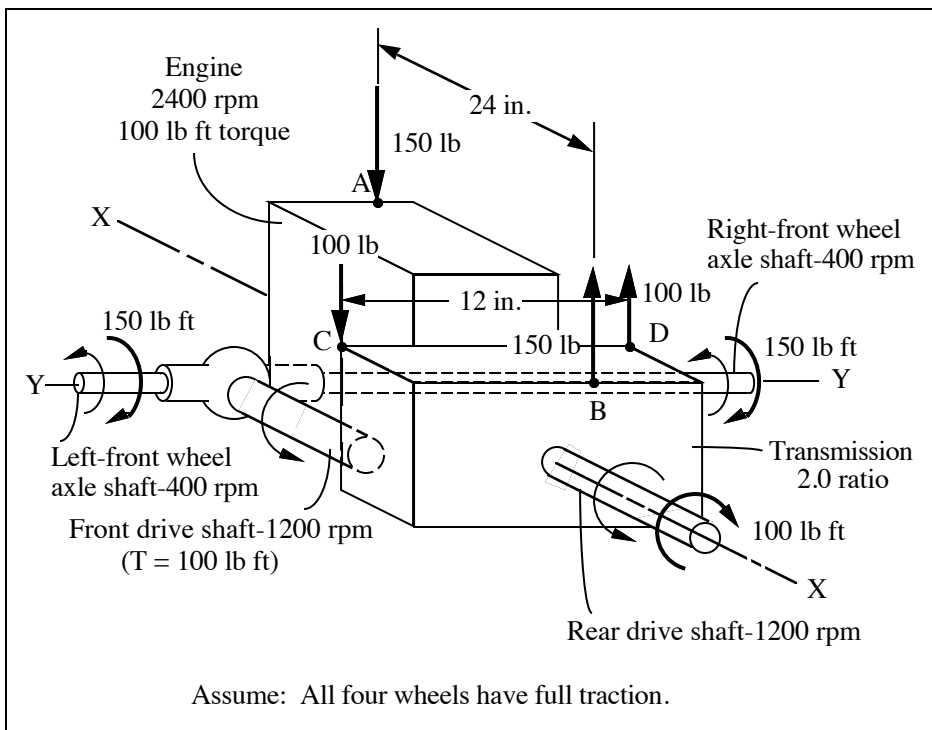

1. Drive shaft torque = $\frac{(\text{Engine torque})(\text{Transmission ratio})}{\text{Number of drive shafts}}$
 $= (100)(2)/2 = 100 \text{ lb ft}$
2. Wheel torque = $\frac{(\text{Drive shaft torque})(\text{Axle ratio})}{\text{Number of wheels per drive shaft}}$
 $= (100)(3)/2 = 150 \text{ lb ft}$
3. Therefore, A: 150 lb down
 B: 150 lb up
 C: 100 lb down
 D: 100 lb up



SOLUTION (2.43D)

Known: A mixer is supported by symmetric mounts at A and B. The motor torque should be 20 N·m to 50 N·m. The motor delivers a torque to mixing paddles which, in turn, stir a fluid to be mixed.

Find: Determine the forces acting on the mixer. Sketch a free-body of the mixer.

Schematic and Given Data:

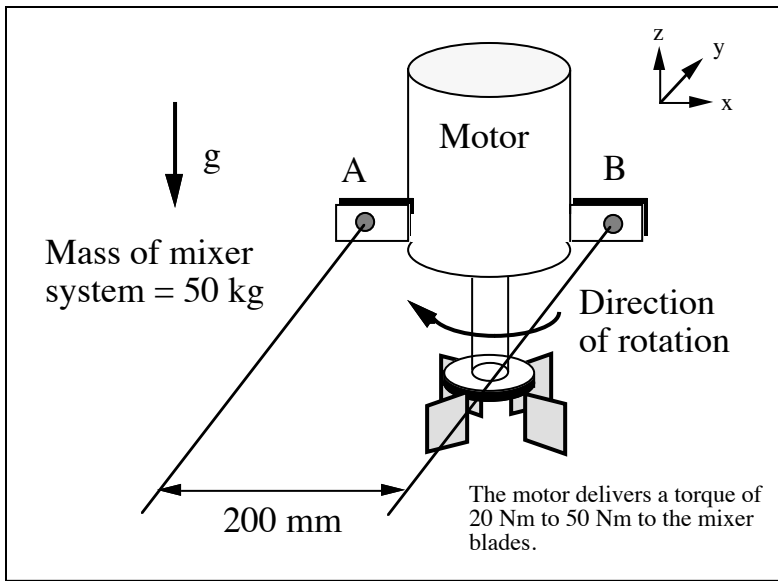

Decision: A motor with a maximum torque output of 50 N·m is selected for analysis.

Assumption: The fluid forces on the paddles create a torque to oppose the rotation of the paddles. Other fluid forces can be neglected (e.g. the paddles are buoyed up by the weight of the displaced fluid).

Analysis:

1. The torque exerted on the paddles by the fluid is 50 N·m maximum.
2. Mounting forces to resist torque = $(50 \text{ N}\cdot\text{m}) / (0.2 \text{ m}) = 250 \text{ N}$. Thus, a force of 250 N is exerted at A and at B.
3. Gravitational forces apply $F = ma = (50 \text{ kg})(9.8 \text{ m/s}^2) = 490 \text{ N}$. Thus, there is a 245 N force upward at A and at B.
4. The forces are shown on the free body diagram for the maximum motor torque of 50 N·m.

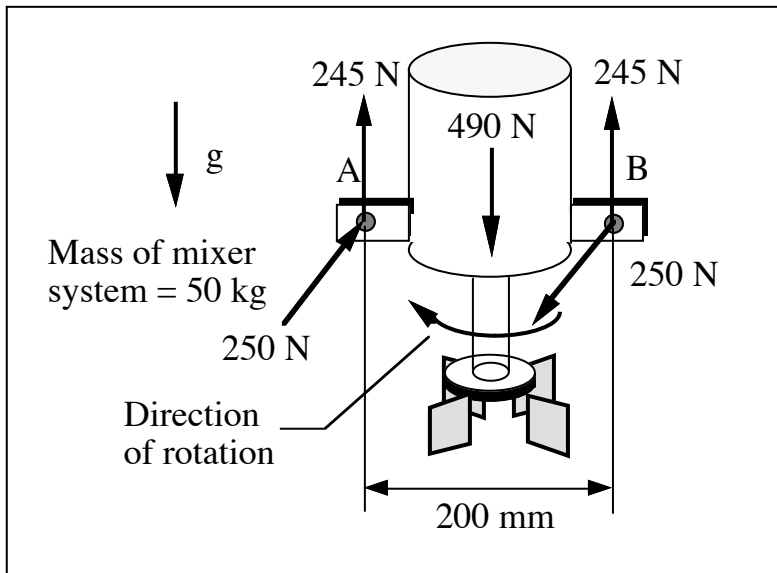

Comment: For torques less than 50 N·m, the resultant mounting forces will be smaller.

SOLUTION (2.44new)

Known: A rear wheel driven vehicle travels at a steady speed. The forces opposing the motion of the vehicle are (i) the drag force, F_d , imposed on a vehicle by the surrounding air, (ii) the rolling resistance force on the tires, F_r , and (iii) the forces of the road acting on the tires. The vehicle has a weight W .

Find: Draw a free body diagram of the rear wheel driven vehicle. Describe how the free body diagram changes if the accelerator pedal is pushed and the vehicle starts accelerating.

Schematic and Given Data:

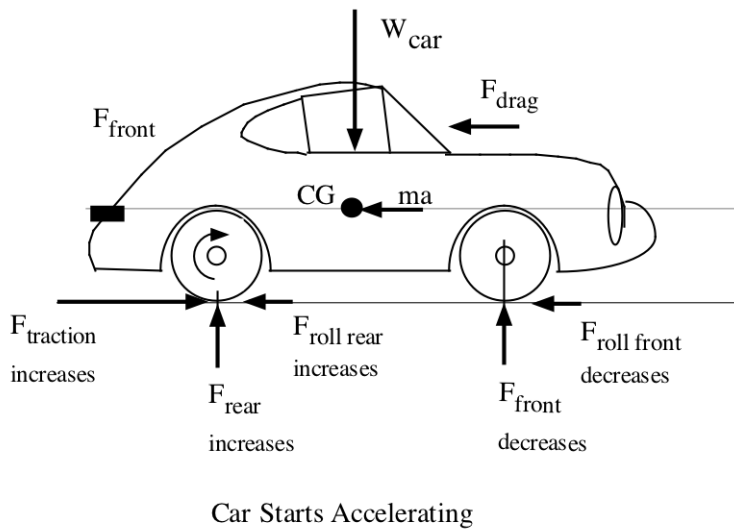
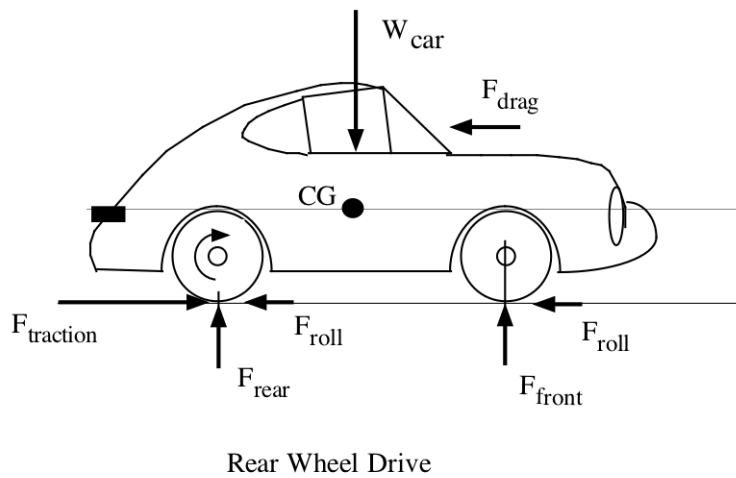

Assumptions: The vehicle is operating initially at steady state conditions.

Comment: The acceleration of the vehicle results from an increase in traction force, and the additional force to acceleration the vehicle is directly related to its mass and its acceleration; i.e., $F = ma$. ■

SOLUTION (2.45new)

Known:

A front wheel driven vehicle travels at a steady speed. The opposing forces are the (i) drag force, F_d , imposed on a vehicle by the surrounding air and the (ii) rolling resistance force on the tires, F_r , opposing the motion of the vehicle, and (iii) the forces of the road acting on the tires. The vehicle has a weight W .

Find: Draw a free body diagram for a front wheel driven vehicle. Describe how the free body diagram changes if the accelerator pedal is pushed and the vehicle starts accelerating.

Schematic and Given Data:

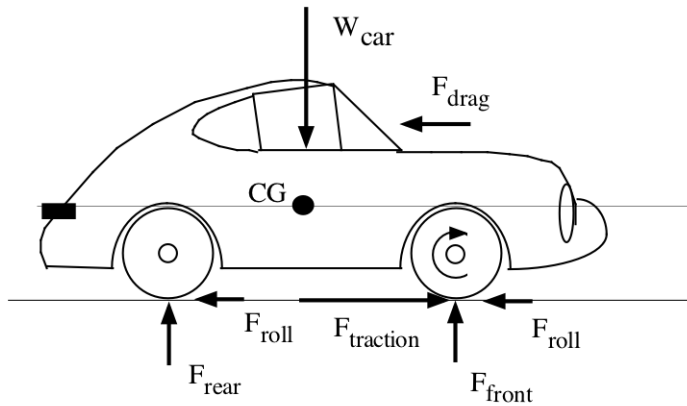

Front Wheel Drive

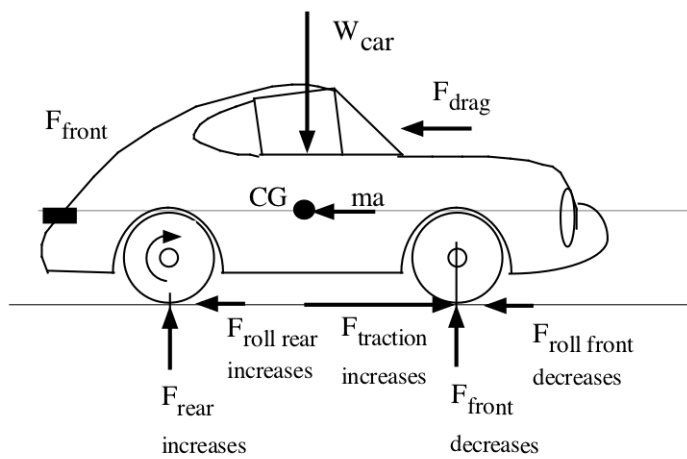

Car Starts Accelerating

Assumptions: The vehicle is initially operating at steady state conditions.

Comment: Free body diagrams are shown above. Although the front tire force(s) decreases with acceleration, this is only a traction problem if the front wheel(s) loses a grip on the road. ■

SOLUTION (2.46new)

Known: The handles are approximately 2.5 inches long and the handle wire is 1/16 inch in diameter. The spring clip is shaped like a triangle when closed (end view) and has two legs each 1-1/4 inches long and a third connecting side that is 1 inch long. The spring clip is approximately 2 inches wide.

Find: Draw a free body diagram for a large size binder clip where the clip is opened and being readied to fasten together a stack of loose 8.5 x 11 inch sheets of paper. Also, draw free-body diagrams for the handles and a diagram for the spring steel clip.

Schematic and Given Data:

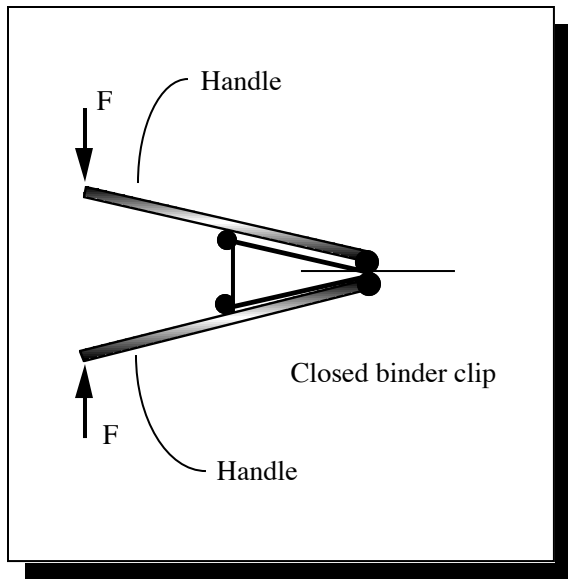

(a) Side view of spring binder clip with applied force F but where F is less than a force required to open the spring clip

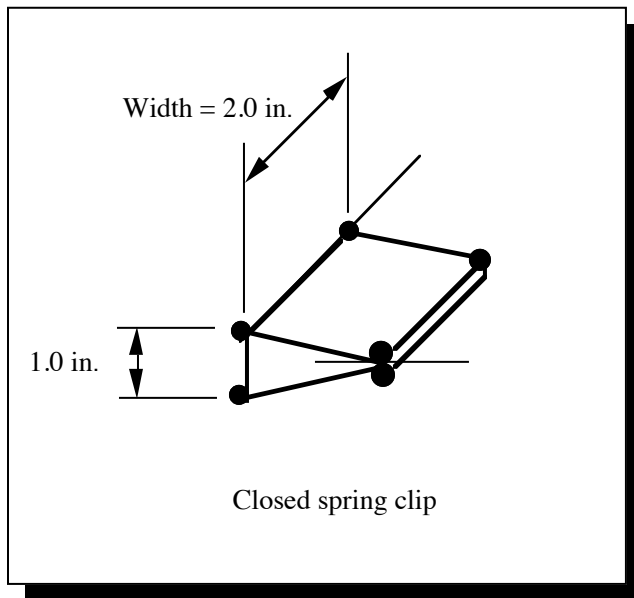

(b) View of spring showing width

Assumption:

1. The weight of each component of the binder clip can be neglected.
2. The externally applied forces are equal and opposite to each other and collinear.

Analysis: A free body of the binder clip with external forces opening the clip appears as shown below. Also shown are free body diagrams for the spring and the two handles.

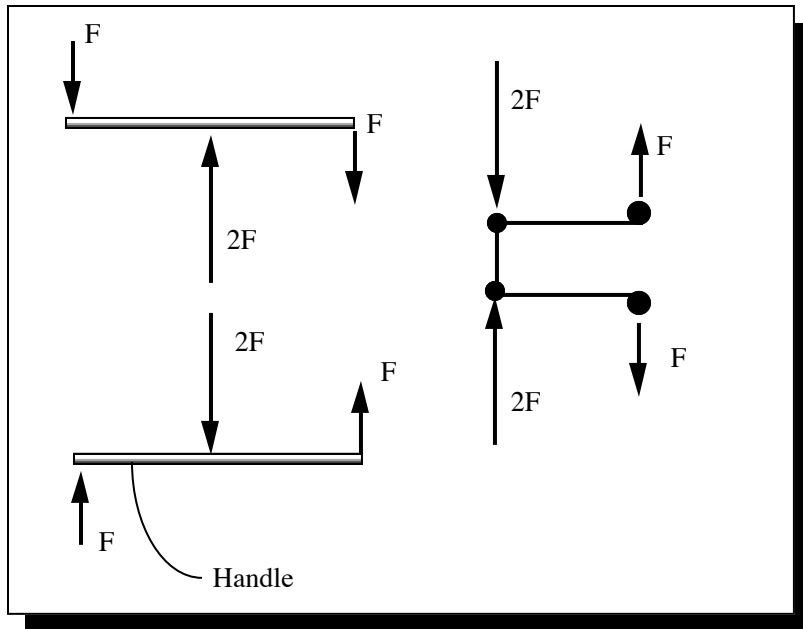
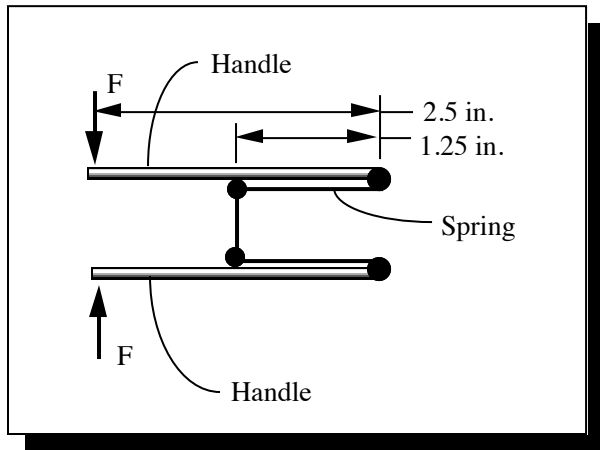

Comments:

1. The diagram of the binder clip is representative of the contact on the handle and spring when collinear external forces are applied.
2. The diagram above does not show the bending of the handles and the bending of the legs and back of the spring. ■

SOLUTION (2.47D)

Known: An electric squirrel cage blower motor supported by mountings at A and B delivers a known torque to fan blades.

Find: Determine all loads acting on the motor and sketch it as a free-body in equilibrium.

Schematic and Given Data:

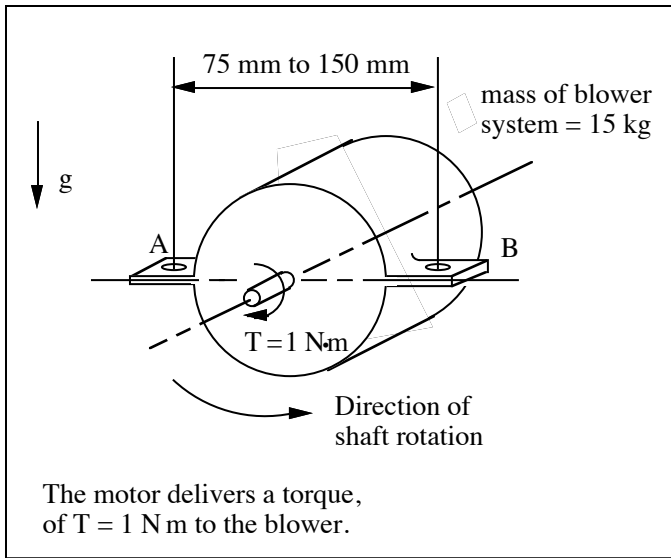

Assumption: The air flows only in the radial direction and exerts a resisting rotational torque on the squirrel cage.

Decision: A width between A and B of 100 mm is selected for analysis.

Analysis:

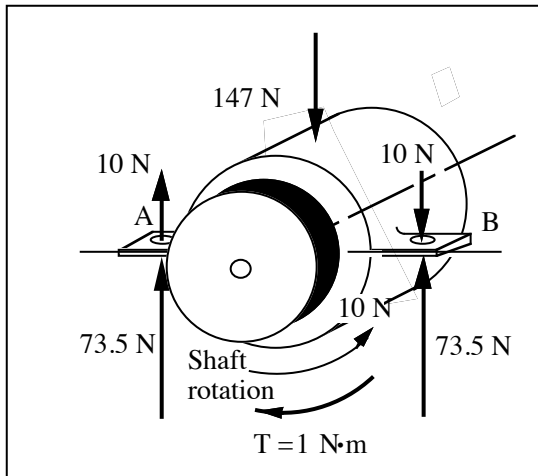

1. The torque exerted on the blades by the wind is 1 N·m.
2. Mounting forces = $(1 \text{ N}\cdot\text{m}) / (0.1 \text{ m}) = 10 \text{ N}$. Thus, 10 N is exerted upward at A and downward at B.

3. Gravitational forces apply $F = ma = (15 \text{ kg})(9.8 \text{ m/s}^2) = 147 \text{ N}$ downward at the center of gravity of the blower unit. Thus, there is a 73.5 N force upward at A and at B.
-

SOLUTION (2.48)

Known: The geometry and dimensions of the gear and shaft assembly are known.

Find: Draw a free-body diagram of the assembly. Also draw the free-body diagrams for gear 1, gear 2 and the shaft.

Schematic and Given Data:

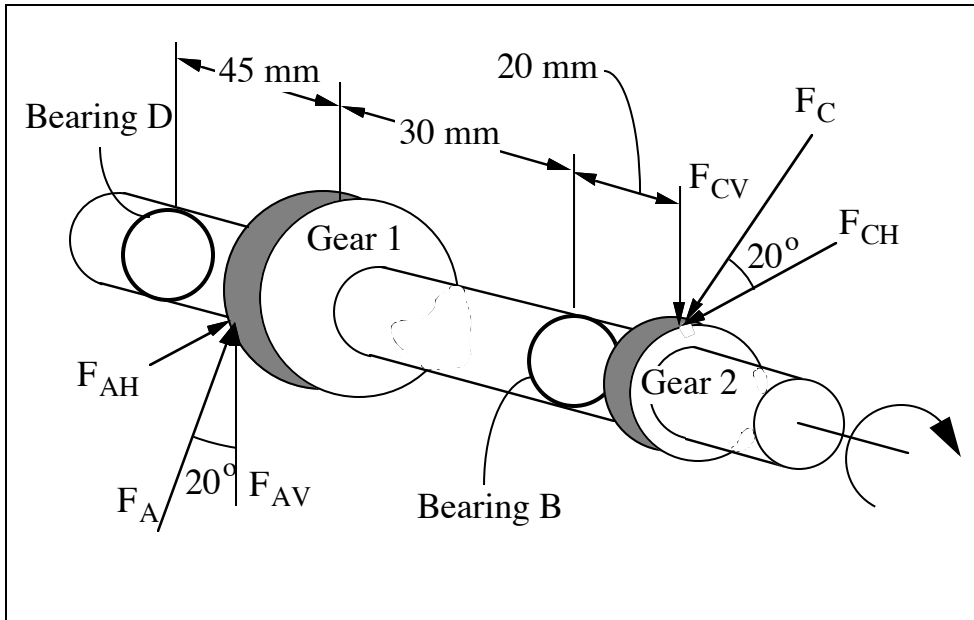

Assumption: Gravity forces are negligible.

Analysis:

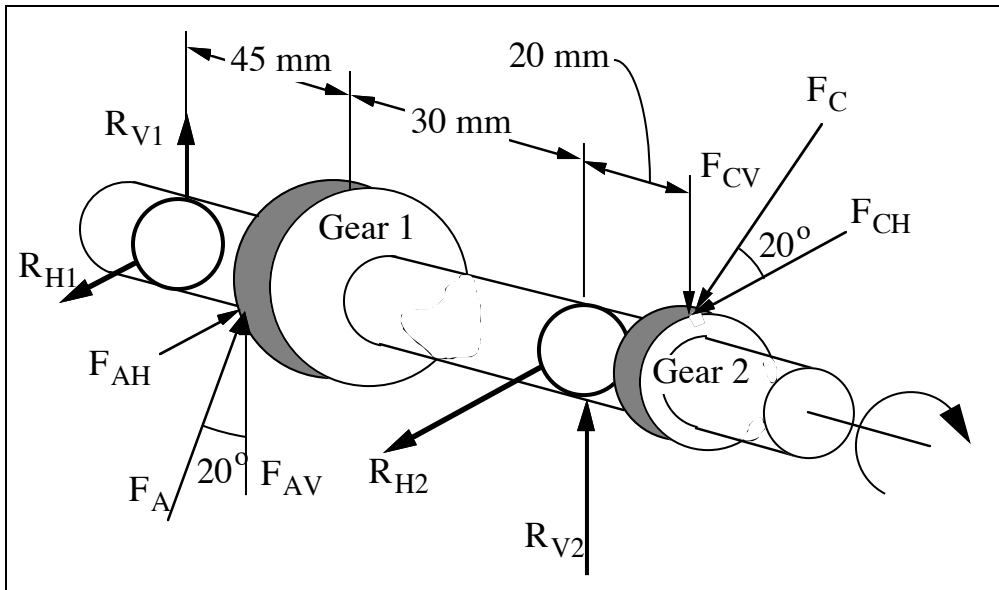

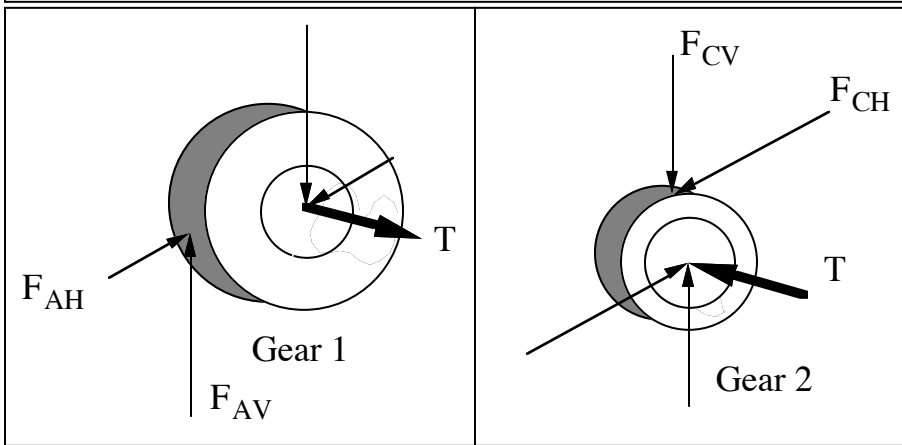
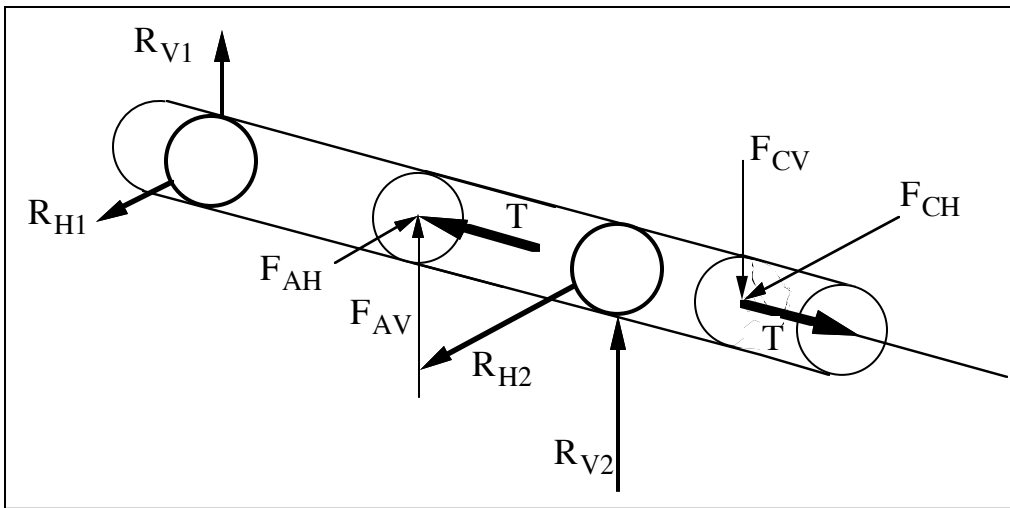

SOLUTION (2.49)

Known: The geometry and dimensions of the gear and shaft assembly are shown in Figure P2.48. The force F_A applied to gear 1 is 550 N.

Find: Determine the magnitude of force F_C and list the assumptions.

Assumptions:

1. Frictional losses in the bearings can be neglected.
2. The gears are rigidly connected to the shafts.
3. The shaft is in static equilibrium or operating in a steady state condition.

Schematic and Given Data:

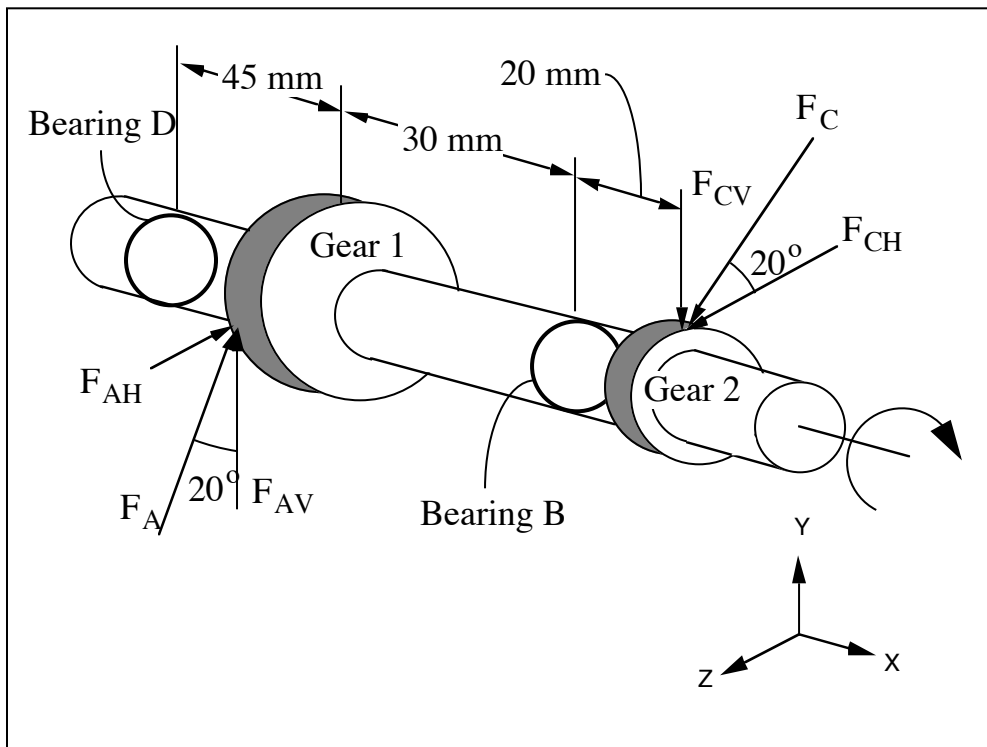

Analysis:

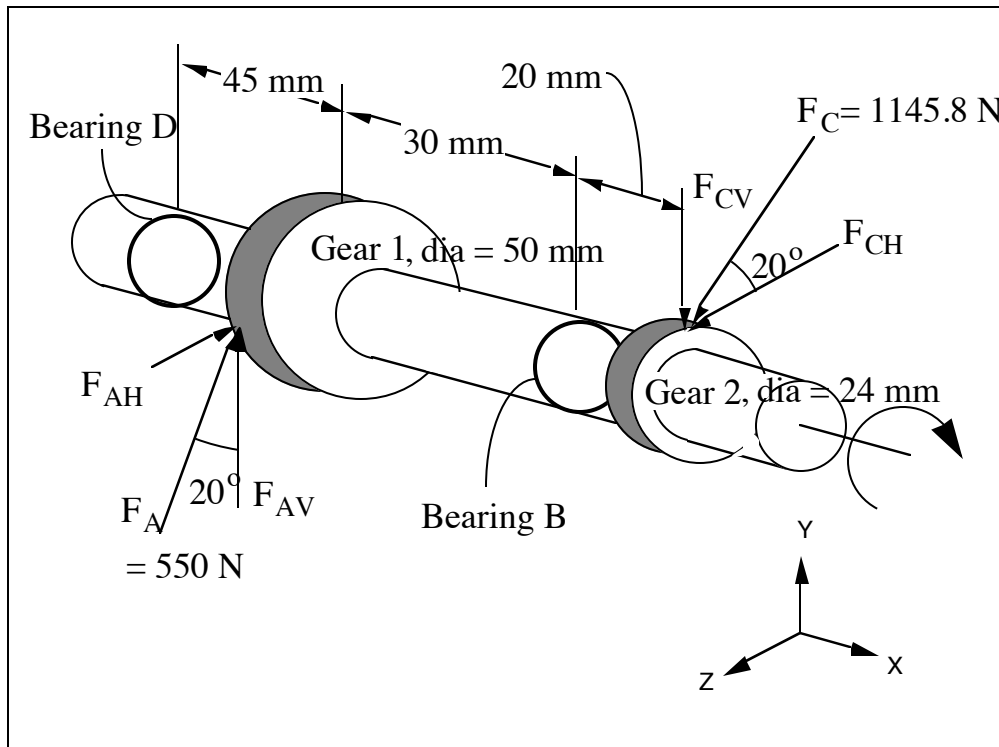

1. Since $\sum T = 0$ about the axis of the shaft, we have $\sum T = F_A \cos 20^\circ (25\text{ mm}) - F_C \cdot \cos 20^\circ (12\text{ mm}) = 0$.
2. Solving the above equation, gives $F_C = F_A \cdot (25/12) = 1145.8\text{ N}$ ■

Comment: Recall that gear 1 has a diameter of 50 mm and gear 2 has a diameter of 24 mm; i.e., gear 1 has a radius of 25 mm and gear 2 has a radius of 12 mm.

SOLUTION (2.50)

Known: The geometry and dimensions of a gear shaft are shown in Figure P2.48. The force F_A applied to gear 1 is 1000 N.

Find: Determine the forces at bearing D and list the assumptions.

Assumptions:

1. There is no thrust load on the shaft.
2. The free body diagram determined in problem 2.48 is accurate.
3. Frictional losses in the bearings can be neglected.
4. Gravity forces and shaft deflection are negligible.
5. The location of the bearing loads can be idealized as points.
6. The gears are rigidly connected to the shafts.
7. The shaft is in static equilibrium or operating in a steady state condition.

Schematic and Given Data:

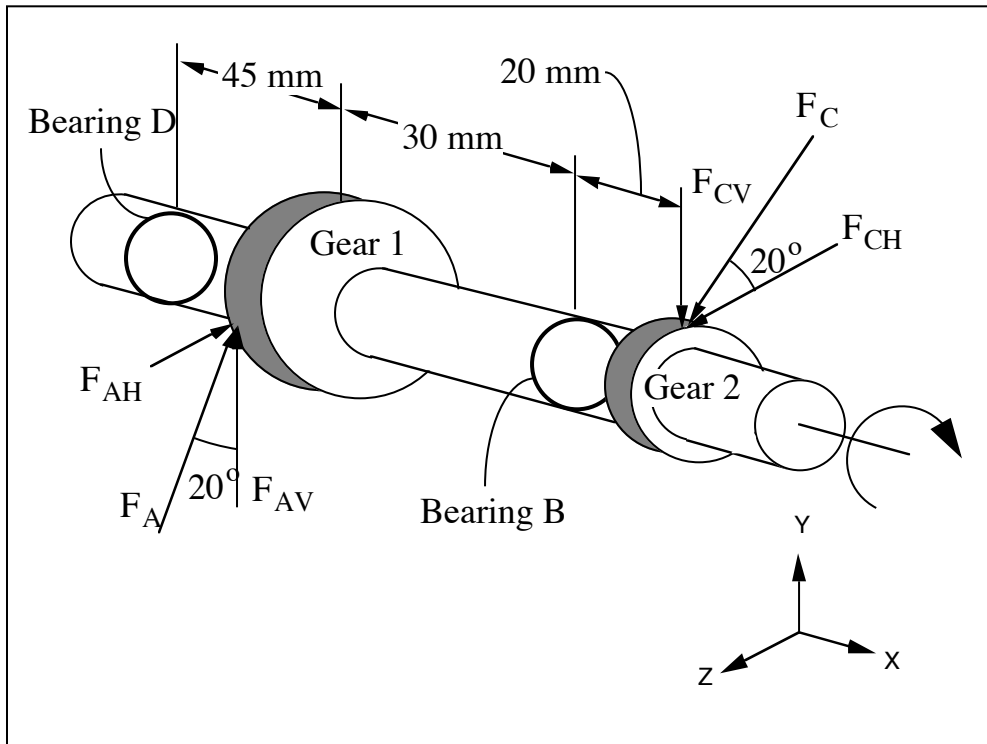

Analysis:

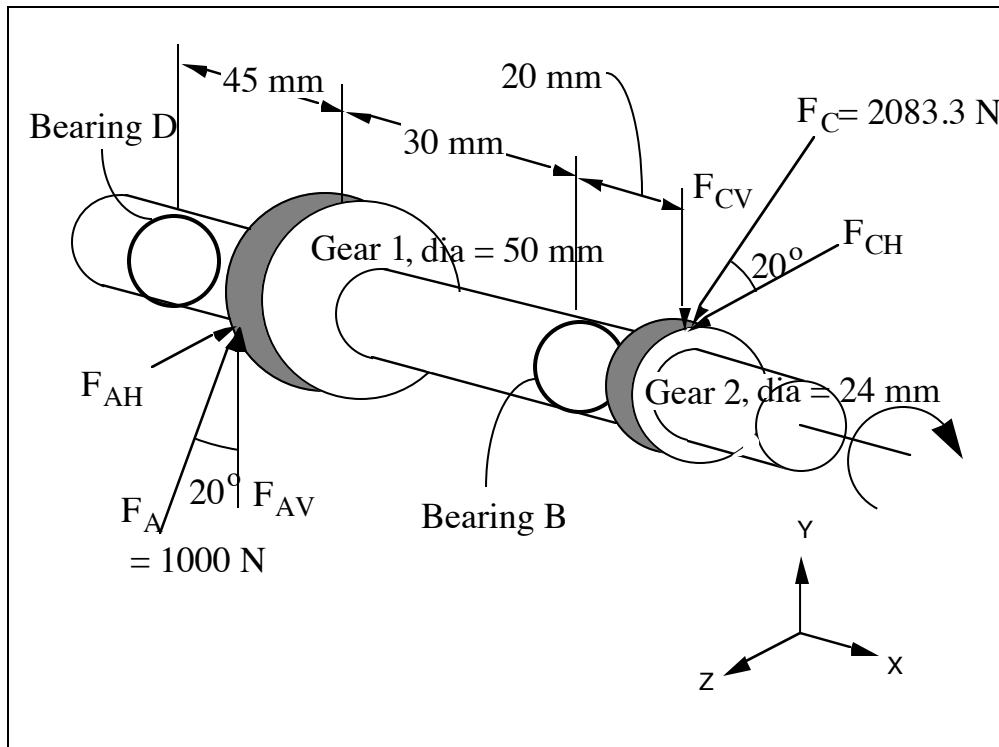

1. Summing moments about the X axis gives $F_C = F_A (25/12) = 1000(25/12) = 2083.3\text{ N}$.
2. Using the free body diagram created, we can directly write the equations of equilibrium for the moments about the bearing B.
3. The sum of the moments about the Z-axis at B is given by

$$\Sigma M_{ZB} = 0 = F_{DV}(45+30) + (F_A \cos 20^\circ)(30) + (F_C \sin 20^\circ)(20)$$

$$\text{Solving for } F_{DV} = -565.9\text{ N}$$

4. Similarly for the Y axis

$$\Sigma M_{YB} = 0 = F_{DH}(45+30) - (F_A \sin 20^\circ)(30) - (F_C \cos 20^\circ)(20)$$

$$\text{Solving for } F_{DH} = 658.9\text{ N}$$

Comments: Summing moments about the Y axis, $\Sigma M_{YD} = 0$ and then the Z axis, $\Sigma M_{ZD} = 0$ at bearing D yields bearing forces at B of $F_{BV} = 338.7\text{ N}$ and $F_{BH} = -2275\text{ N}$. We can check the answers by verifying that the sum of the forces in the Y direction and then the Z direction are both equal to zero.

SOLUTION (2.51)

Known: The geometry and dimensions of a gear shaft are shown in Figure P2.48. The force F_C applied to gear 2 is 750 N.

Find: Determine the forces at bearing B and list the assumptions.

Assumptions:

1. There is no thrust load on the shaft.
2. The free body diagram determined in problem 2.48 is accurate.
3. Frictional losses in the bearings can be neglected.
4. Gravity forces and shaft deflection are negligible.
5. The location of the bearing loads can be idealized as points.
6. The gears are rigidly connected to the shafts.
7. The shaft is in static equilibrium or operating in a steady state condition.

Schematic and Given Data:

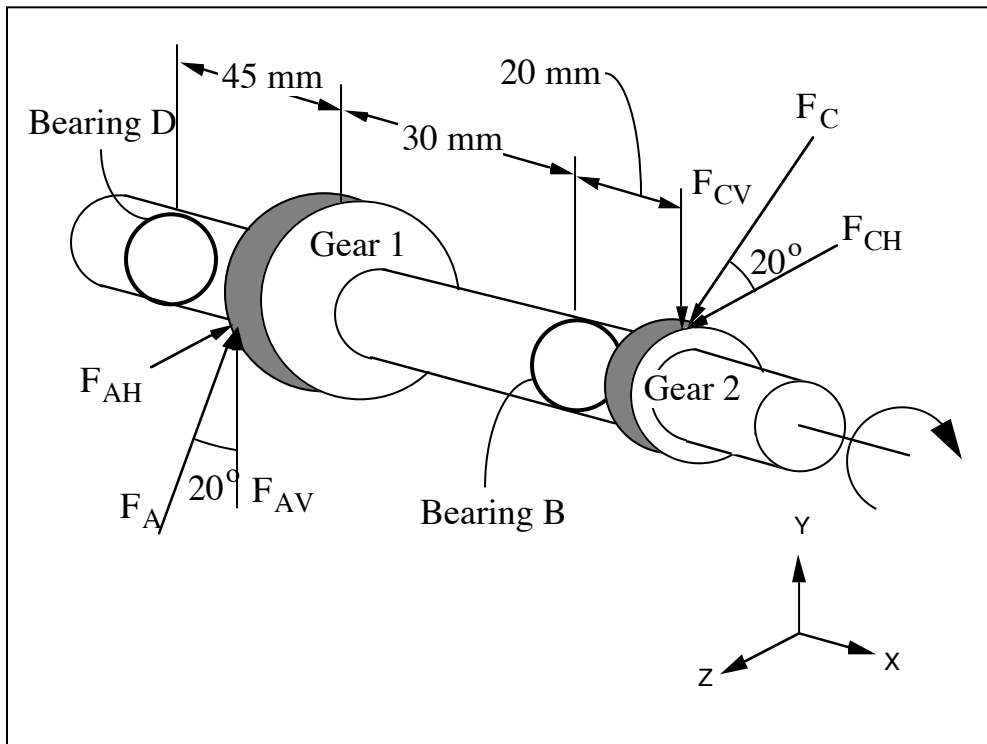

Assumption: Gravity forces are negligible.

Analysis:

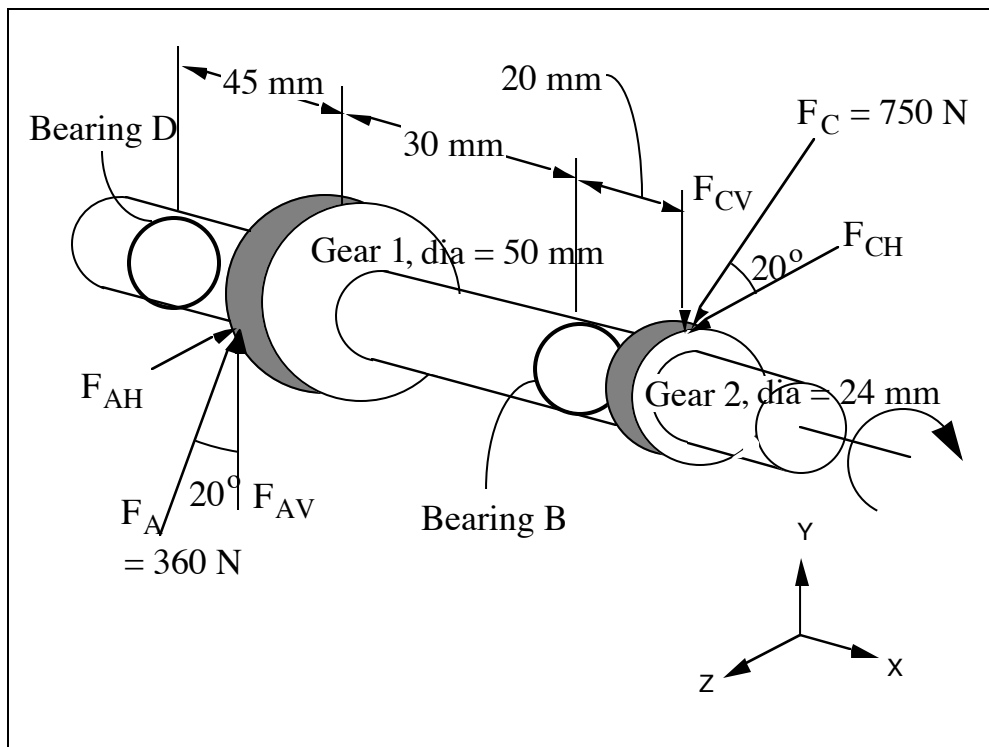

1. Summing moments about the X axis gives $F_A = F_C (12/25) = 750(12/25) = 360\text{N}$
2. Using the free body diagram created, we can directly write the equations of equilibrium for the moments about the bearing D.
3. The sum of the moments about the Z-axis at D is given by

$$\Sigma M_{ZB} = 0 = F_{BV}(45+30) + F_A \cos 20^\circ (45) - F_C \sin 20^\circ (45 + 30 + 20)$$

$$\text{Solving for } F_{BV} = 121.9 \text{ N} \quad \blacksquare$$

4. Similarly for the Y-axis

$$\Sigma M_{YB} = 0 = -F_{BH}(45+30) + F_A \sin 20^\circ (45) - F_C \cos 20^\circ (45 + 30 + 20)$$

$$\text{Solving for } F_{BH} = -818.8 \text{ N} \quad \blacksquare$$

Comments: Summing moments about the Z axis and then the Y axis at bearing D yields bearing forces at D of $F_{DV} = -203.7 \text{ N}$ and $F_{DH} = 237.2 \text{ N}$. We can check the answers by verifying that the sum of the forces in the Y direction and then the Z direction are both equal to zero.

SOLUTION (2.52)

Known: The solid continuous member shown in textbook Figure P2.52 can be viewed as comprised of several straight segments. The member is loaded as shown. We are to neglect the weight of the member.

Find: Draw free-body diagrams for the straight segments 1, 2, and 3. Also, determine the magnitudes (symbolically) of the force and moments acting on the straight segments.

Schematic and Given Data:

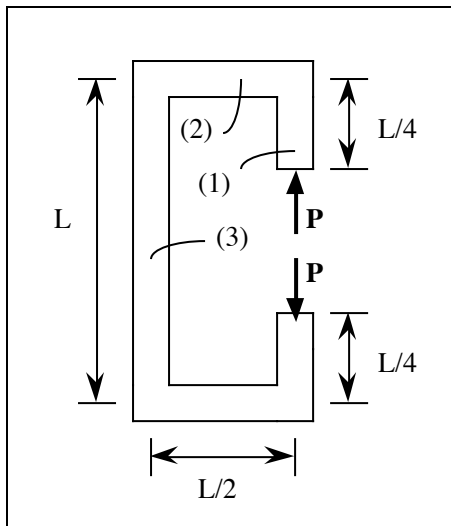

Analysis:

1. Because of symmetry, we need to look only at one half of the member.

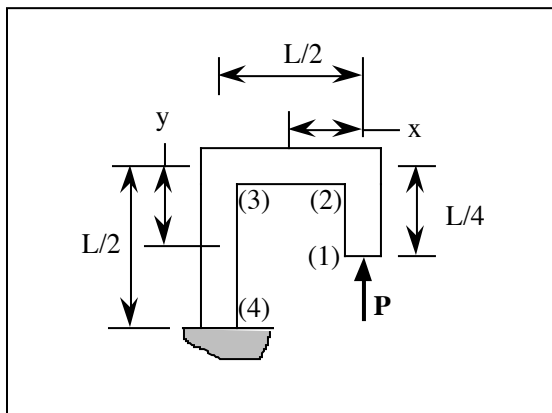

2. In Section 1 to 2, the axial compressive force, $F = P$.
3. In Section 2 to 3, the moment, $M = Px$, and the shear force, $V = P$.
4. In Section 3 to 4, the moment, $M = PL/2$, and the axial tensile force, $F = P$.

SOLUTION (2.53)

Known: A gear exerts the same known force on each of two geometrically different steel shafts supported by self-aligning bearings at A and B.

Find: Draw shear and bending moment diagrams for each shaft.

Schematic and Given Data:

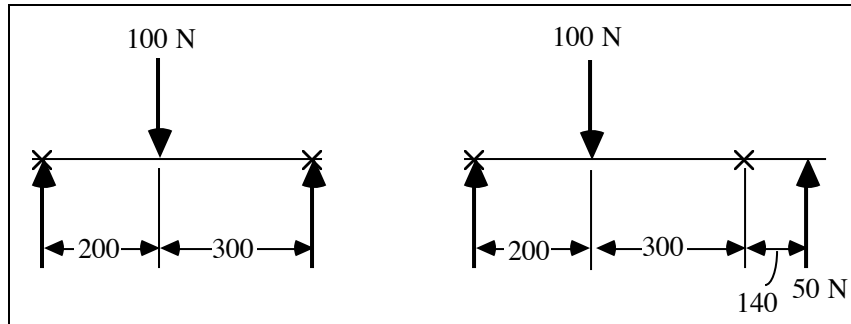

Analysis:

$$F_B = 100 \left(\frac{200}{500} \right) = 40 \text{ N}$$

$$F_B = \frac{-100(200) + 50(640)}{500} = 24 \text{ N}$$

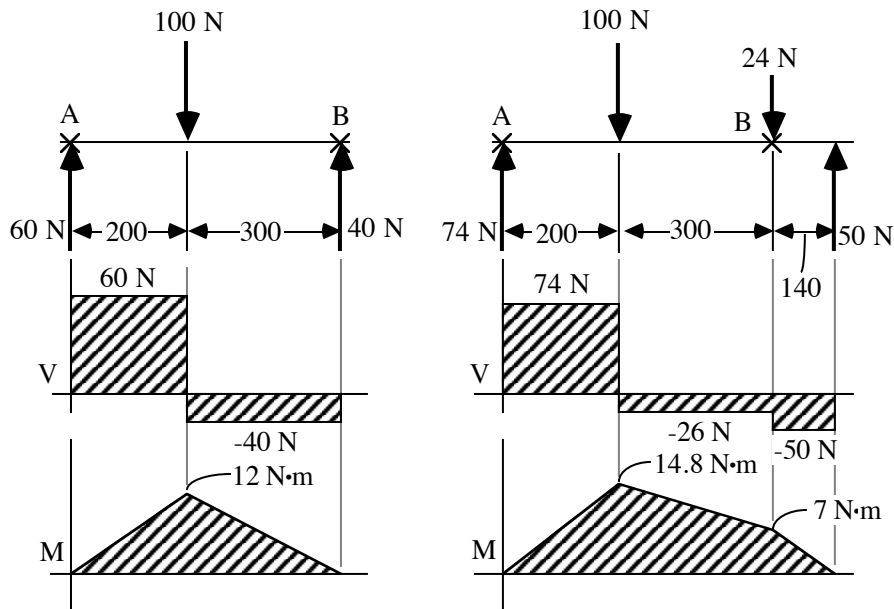

SOLUTION (2.54)

Known: Six shaft loading configurations are shown in Fig. P2.54. For each configuration, the 2-in. diameter steel shaft is supported by self-aligning ball bearings at A and B; and a special 6-in. diameter gear mounted on the shaft caused the forces to be applied as shown.

Find: Determine bearing reactions, and draw appropriate shear and bending moment diagrams for each shaft and gear loading configuration.

Schematic and Given Data:

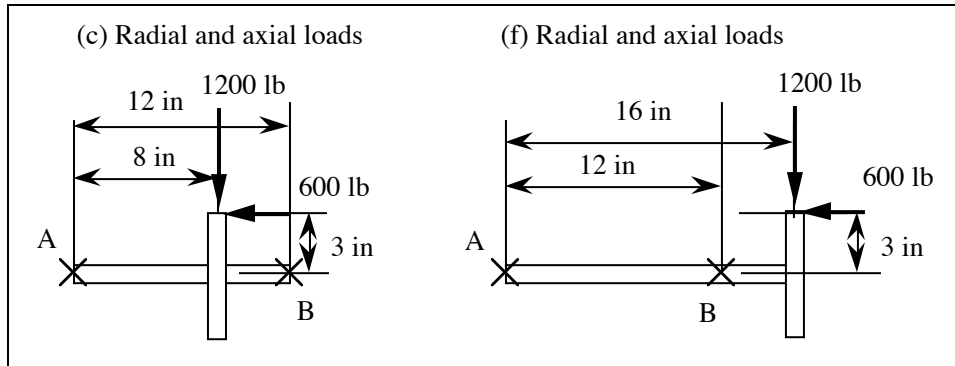

Analysis:

(c) Radial and axial loads

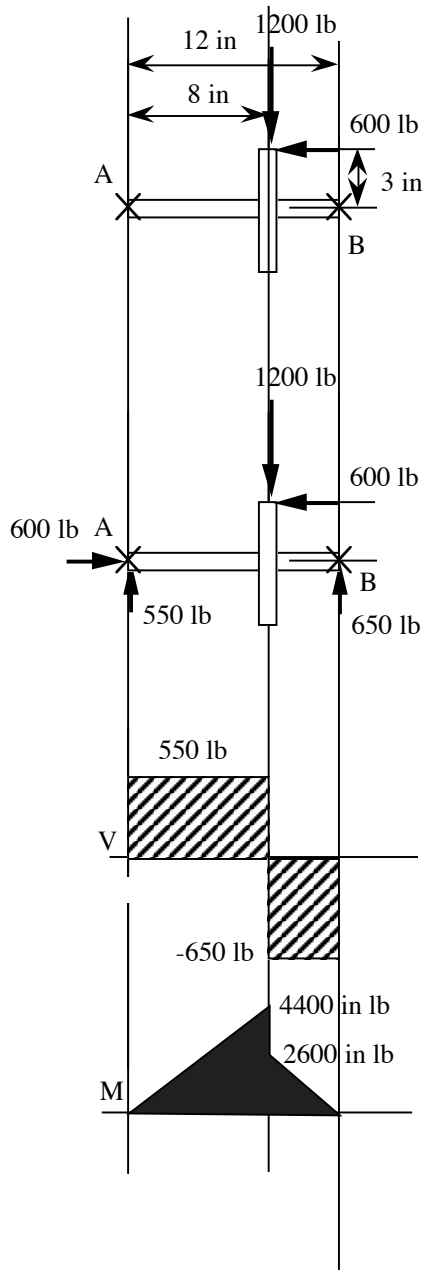

(f) Radial and axial loads

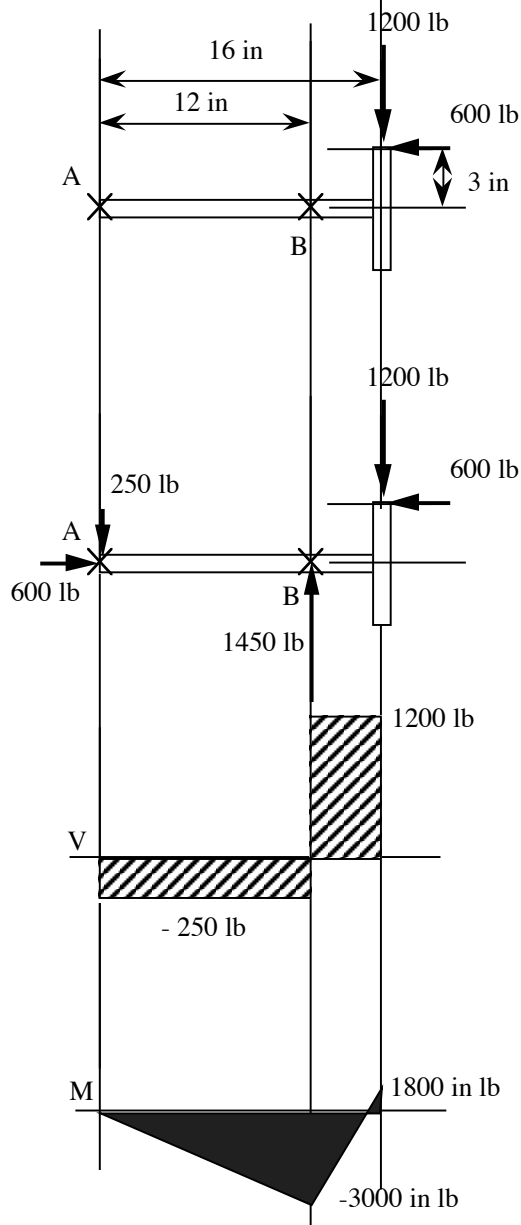

SOLUTION (2.55)

Known: A pulley of known radius is attached at its center to a structural member. A cable wrapped 90° around the pulley carries a known tension.

Find:

- (a) Draw a free-body diagram of the structure supporting the pulley.
- (b) Draw shear and bending moment diagrams for both the vertical and horizontal portions of the structure.

Schematic and Given Data:

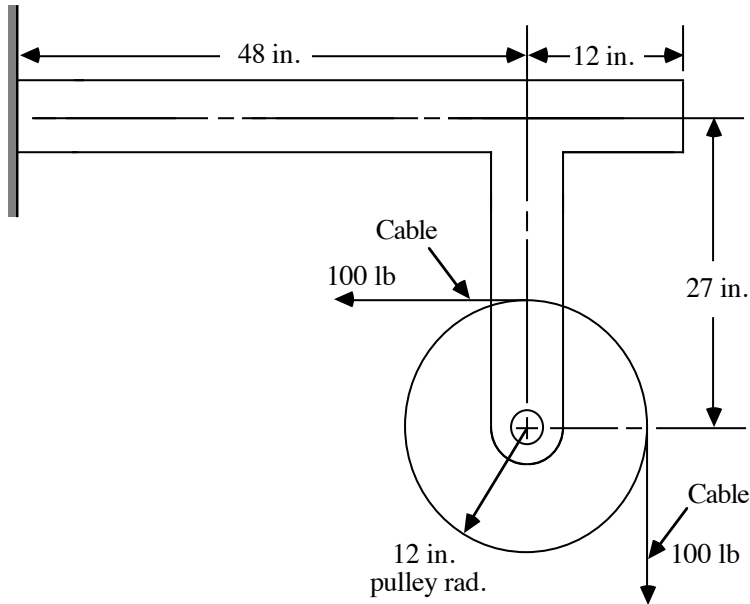

Assumption: The weight of the pulley and the supporting structure is negligible.

Analysis:

- 1. Free-body diagram of the structural member:

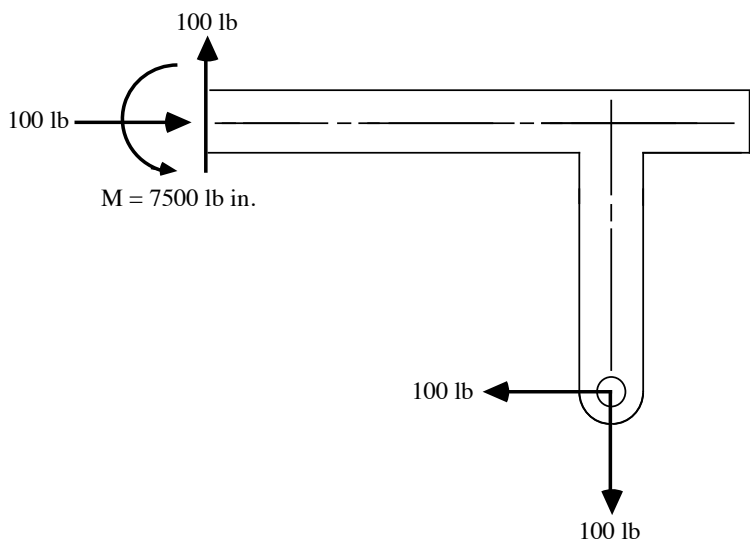

$$M = 100 (27+48) = 7500 \text{ lb in.}$$

2. Vertical portion of member:

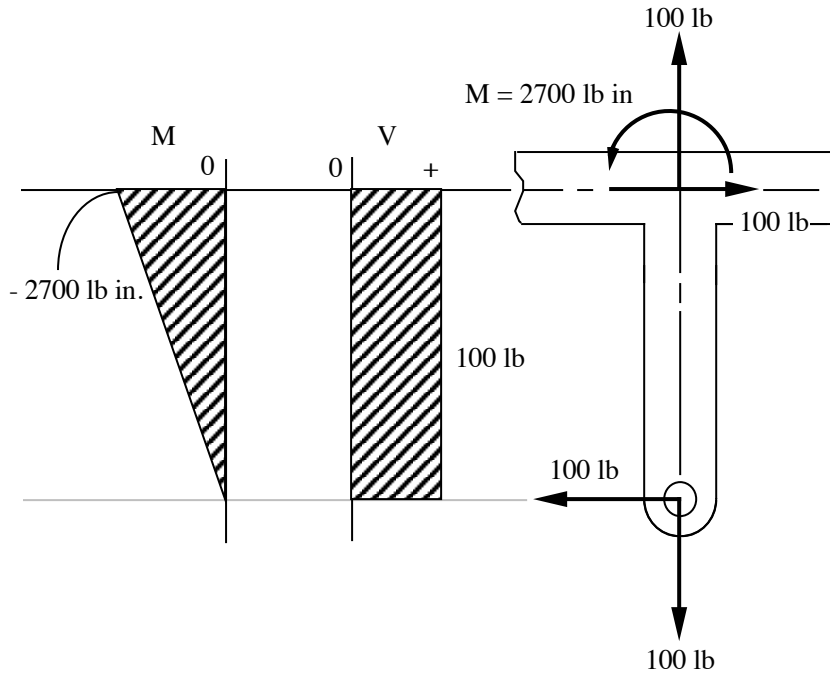

3. Horizontal portion of member:

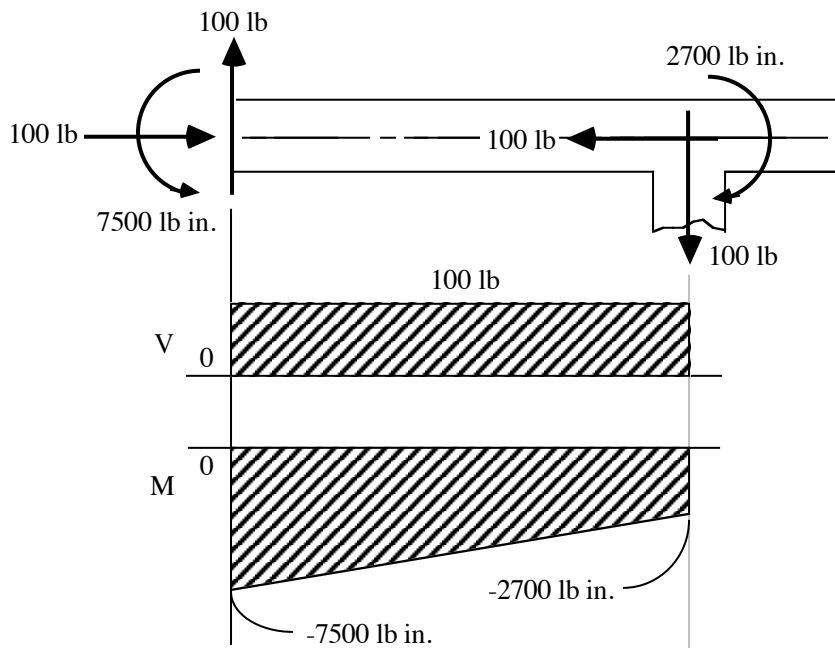

SOLUTION (2.56)

Known: A bevel gear is attached to a shaft supported by self-aligning bearings at A and B, and is driven by a motor. The axial force, radial force, and tangential force are known.

Find:

- (a) Draw (to scale) axial load, shaft torque, shear force, and bending moment diagrams for the shaft.
- (b) Determine the values of axial load and torque along the shaft.

Schematic and Given Data:

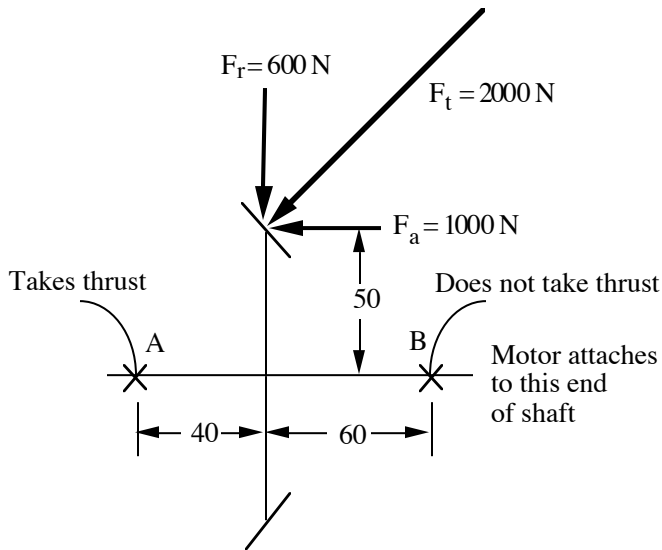

Assumptions:

- 1. The weight of the gear and shaft is negligible.
- 2. The bearing at A takes all the thrust load.

Analysis:

- (a) Since bearing B carries no axial thrust load, $B_x = 0$. A free body diagram of the bevel gear and shaft is:

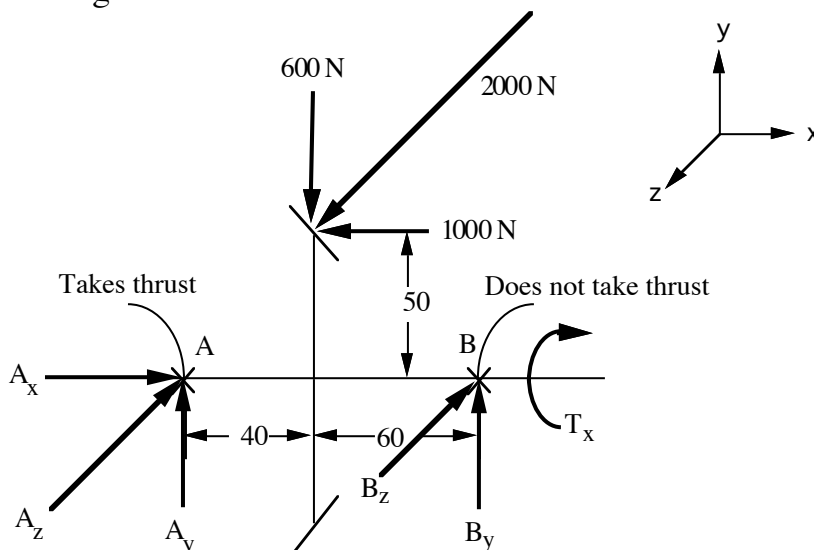

From force equilibrium:

1. $\sum M_{zA} = 0 : B_y = \frac{600(40) - 1000(50)}{100} = -260 \text{ N}$
2. $\sum F_y = 0 : A_y - 600 + B_y = 0; A_y = 860 \text{ N}$
3. $\sum M_{yA} = 0 : (2000)(40) - (B_z)(100) = 0; B_z = 800 \text{ N}$
4. $\sum M_{xx} = 0 : T_x - (2000)(50) = 0; T_x = 100,000 \text{ N mm}$
5. $\sum F_x = 0 : A_x - 1000 \text{ N} = 0; A_x = 1000 \text{ N}$
6. $\sum F_z = 0 : A_z + B_z - 2000 = 0; A_z = 1200 \text{ N}$

The answers are:

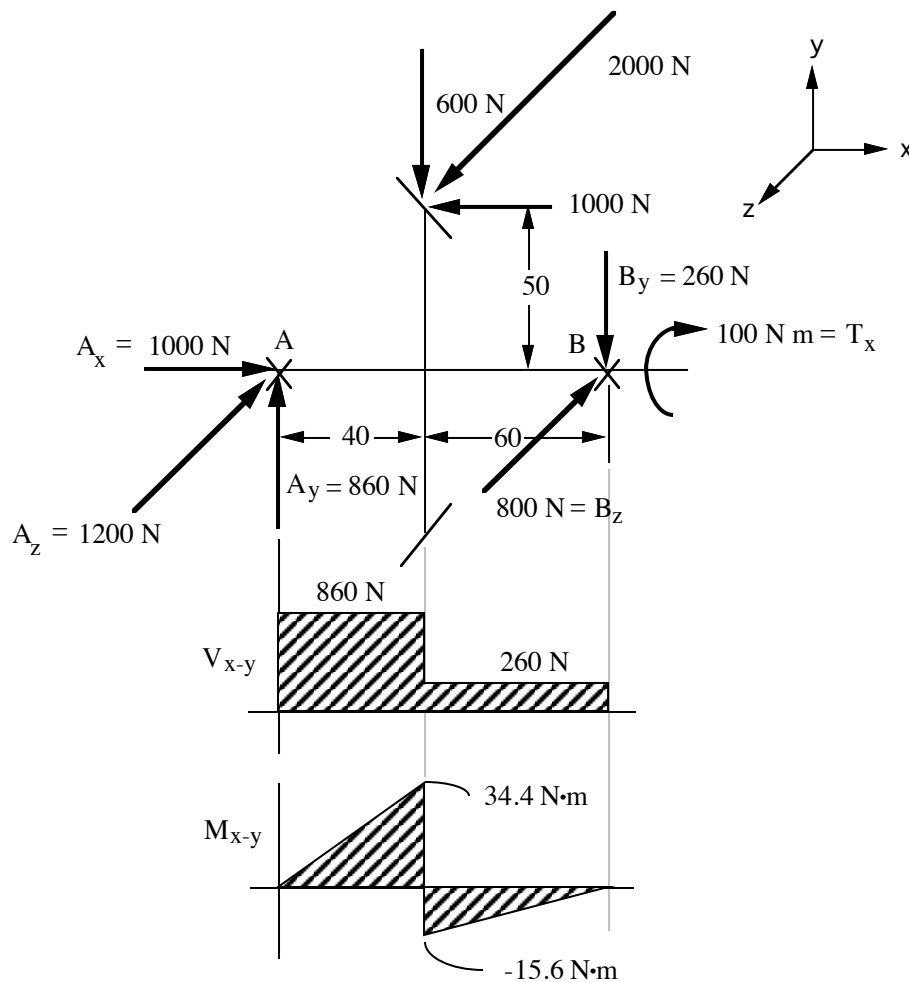

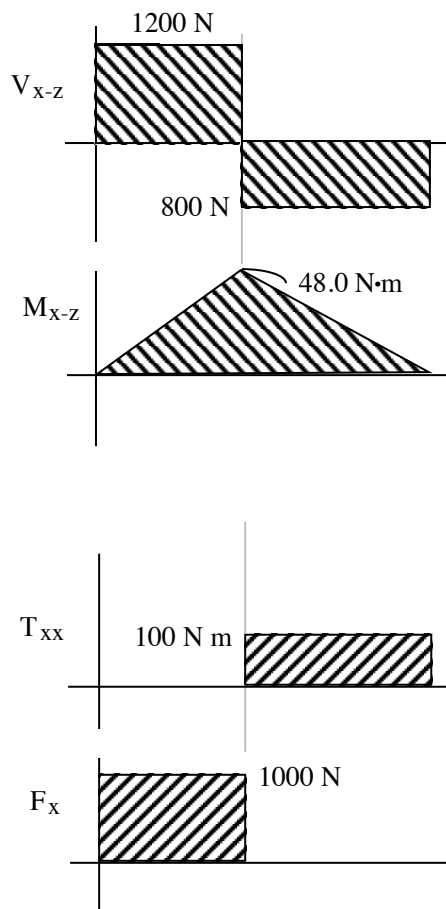

- (b) The compressive force between the gear and the bearing A is 1000 N. The torque between the gear and the bearing B is 50 mm times the tangential gear force, F_t . For $F_t = 2000$ N, this torque is $(2 \text{ kN})(50 \text{ mm}) = 100 \text{ N}\cdot\text{m}$.
-

SOLUTION (2.57)

Known: The shaft with bevel gear is supported by self-aligning bearings A and B. Gear loads are known.

Find: Draw axial load, shaft torque, shear force, and bending moment diagrams for the shaft.

Schematic and Given Data:

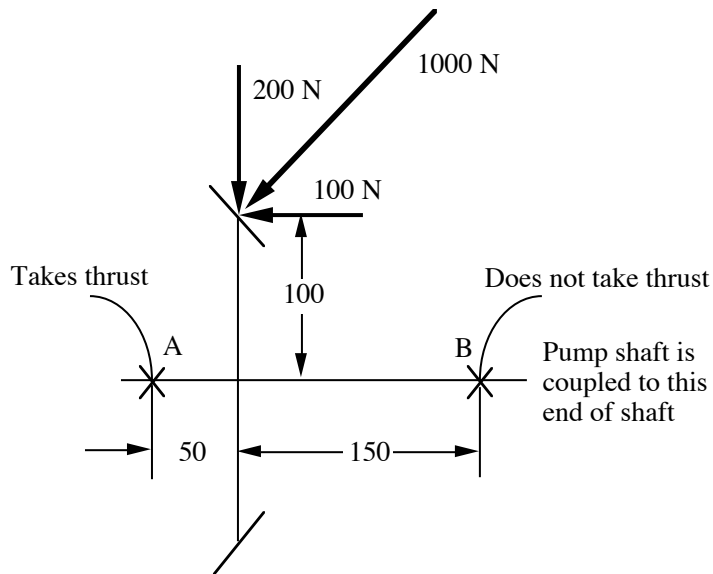

Assumptions:

1. The weight of the gear and shaft is negligible.
2. The bearing at A takes all the thrust load.

Analysis: A free body diagram of the shaft with bevel gear is:

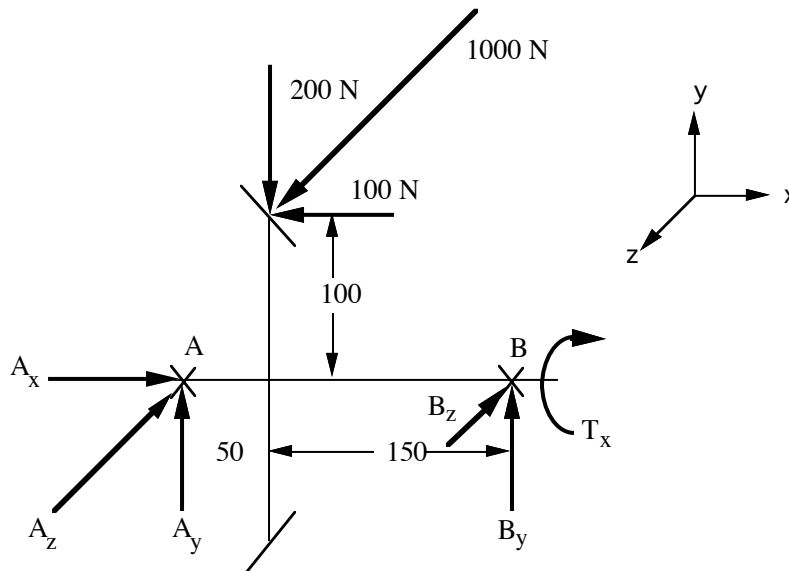

Force equilibrium requires:

1. $\sum M_{zA} = 0 : B_y = \frac{100(100) - 200(50)}{200} = 0 \text{ N}$
2. $\sum F_y = 0 : A_y - 200 + B_y = 0; A_y = 200 \text{ N}$
3. $\sum M_{yA} = 0 : (1000)(50) - (B_z)(200) = 0; B_z = 250 \text{ N}$
4. $\sum M_{xx} = 0 : T_x - (1000)(100) = 0; T_x = 100 \text{ N m}$
5. $\sum F_x = 0 : A_x - 100 = 0; A_x = 100 \text{ N}$
6. $\sum F_z = 0 : A_z + B_z - 1000 = 0; A_z = 750 \text{ N}$

The answers are:

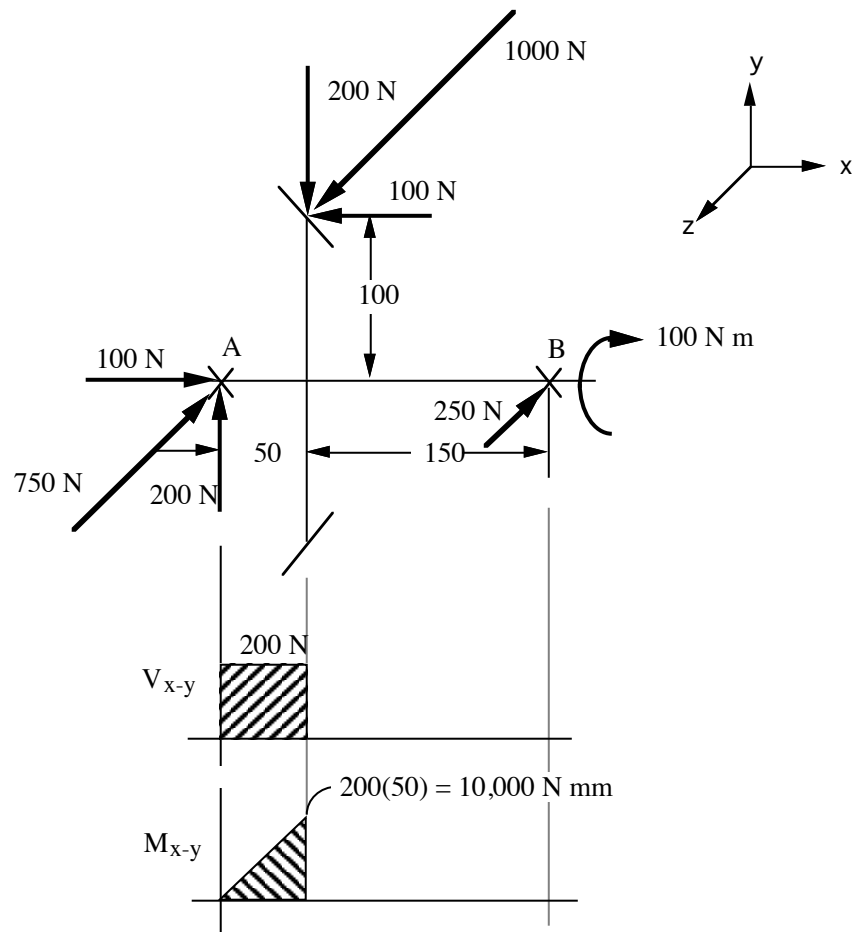

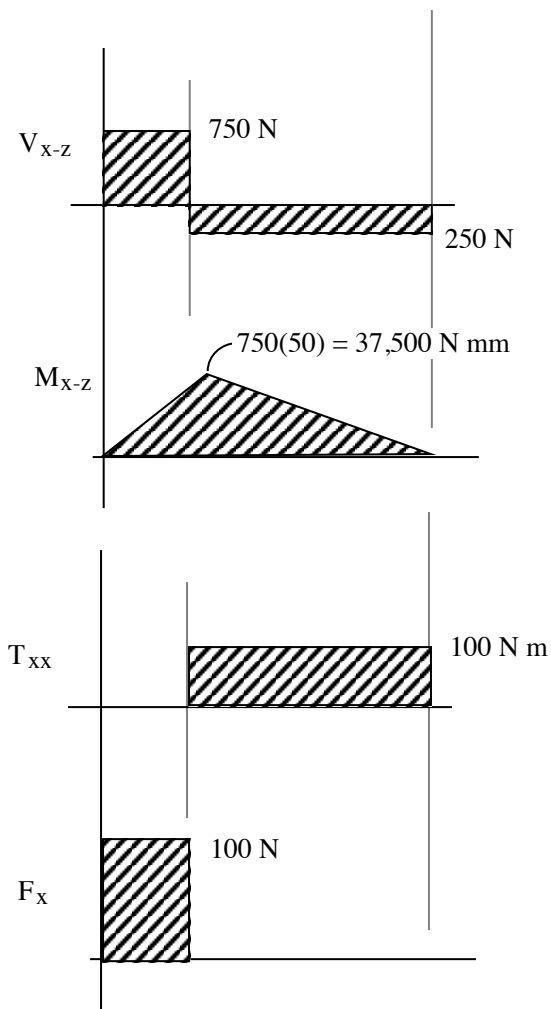

SOLUTION (2.58)

Known: The shaft with a bevel gear and a spur gear is supported by self-aligning bearings A and B. Neither end of the shaft is connected to another component. The gear loads are known except for the transmitted force on the spur gear.

Find: Draw axial load, shaft torque, shear force, and bending moment diagrams for the shaft.

Schematic and Given Data:

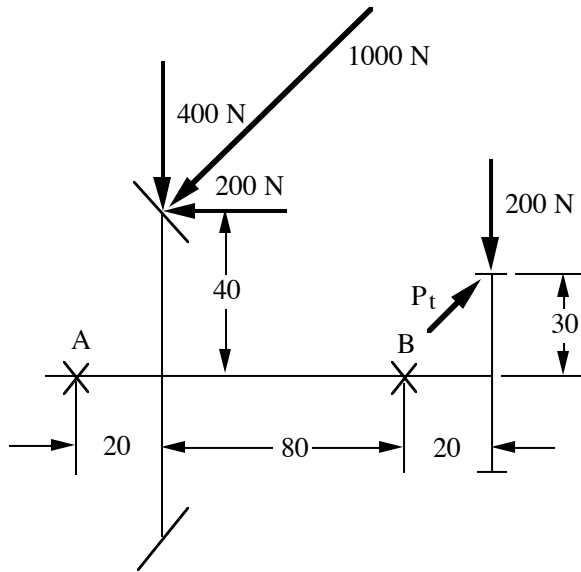

Assumptions:

1. The weight of the components is negligible.
2. The bearing at A carries all the thrust load.

Analysis: A free body diagram of the shaft with bevel gear is:

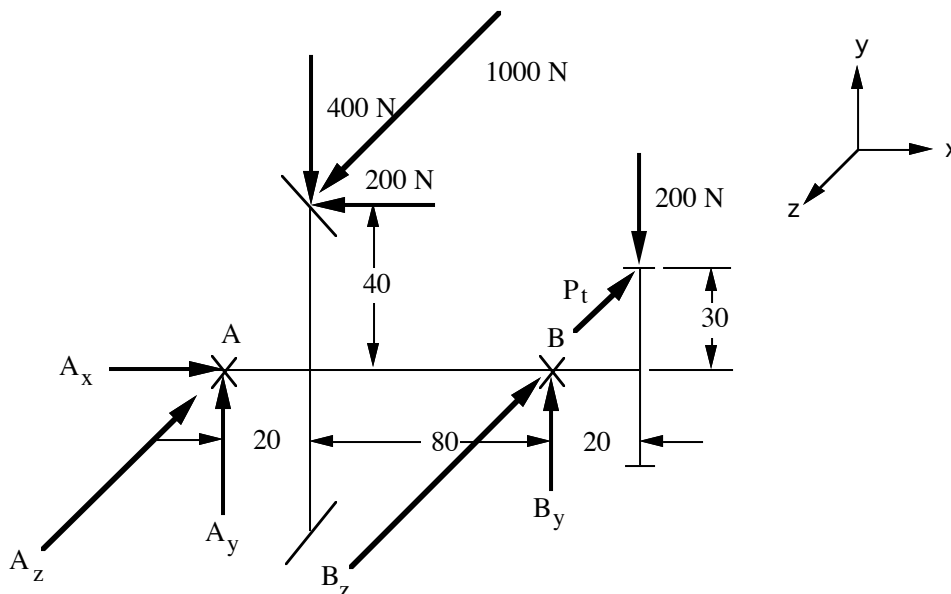

Force equilibrium requires:

1. $\sum F_x = 0 : A_x - 200 = 0; A_x = 200 \text{ N}$
2. $\sum M_{xx} = 0 : -(30)P_t + (1000)(40) = 0; P_t = 1333.33 \text{ N}$
3. $\sum M_{yA} = 0 : (1000)(20) - (B_z)(100) - (120)P_t = 0; B_z = -1400 \text{ N}$
4. $\sum F_z = 0 : A_z - 1000 - 1400 + 1333.33 = 0; A_z = 1066.7 \text{ N}$
5. $\sum M_{zA} = 0 : 400(20) - 200(40) - B_y(100) + 200(120) = 0; B_y = 240 \text{ N}$
6. $\sum F_y = 0 : A_y - 400 + B_y - 200 = 0; A_y = 360 \text{ N}$

The answers are:

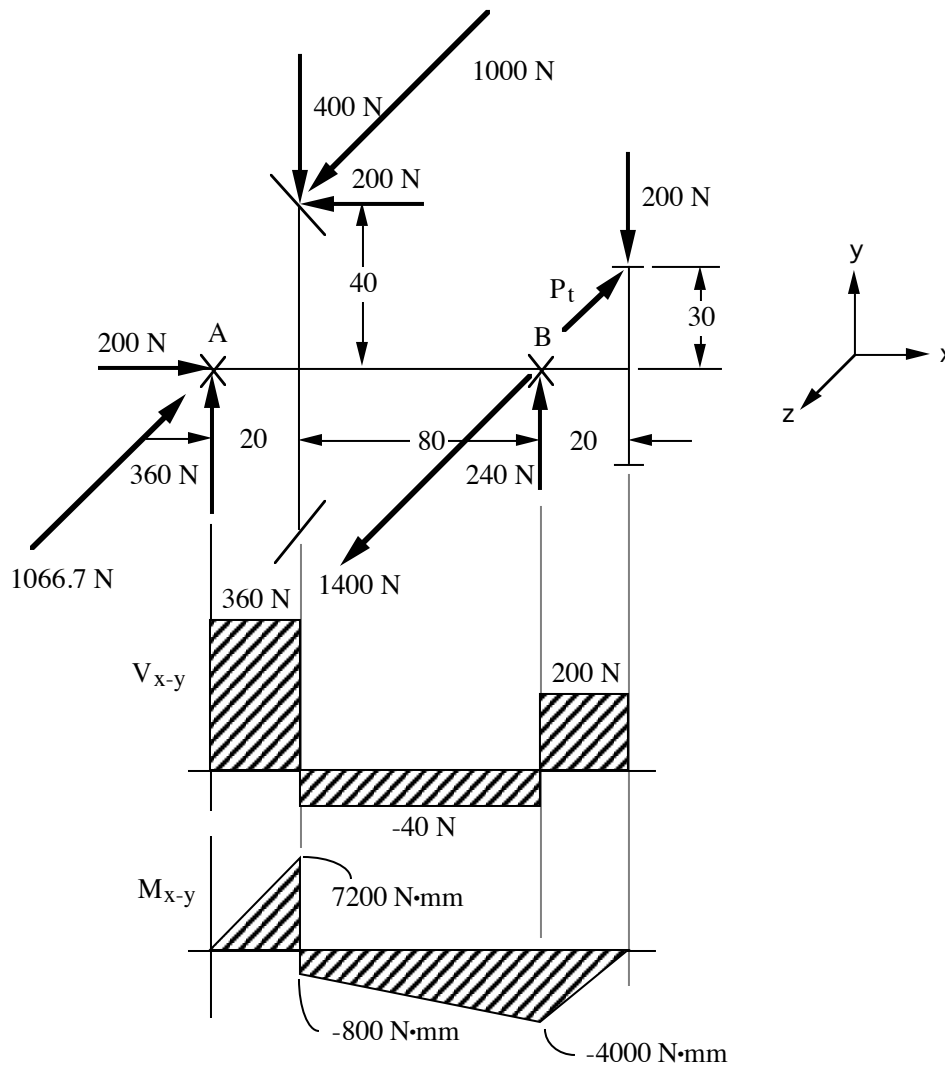

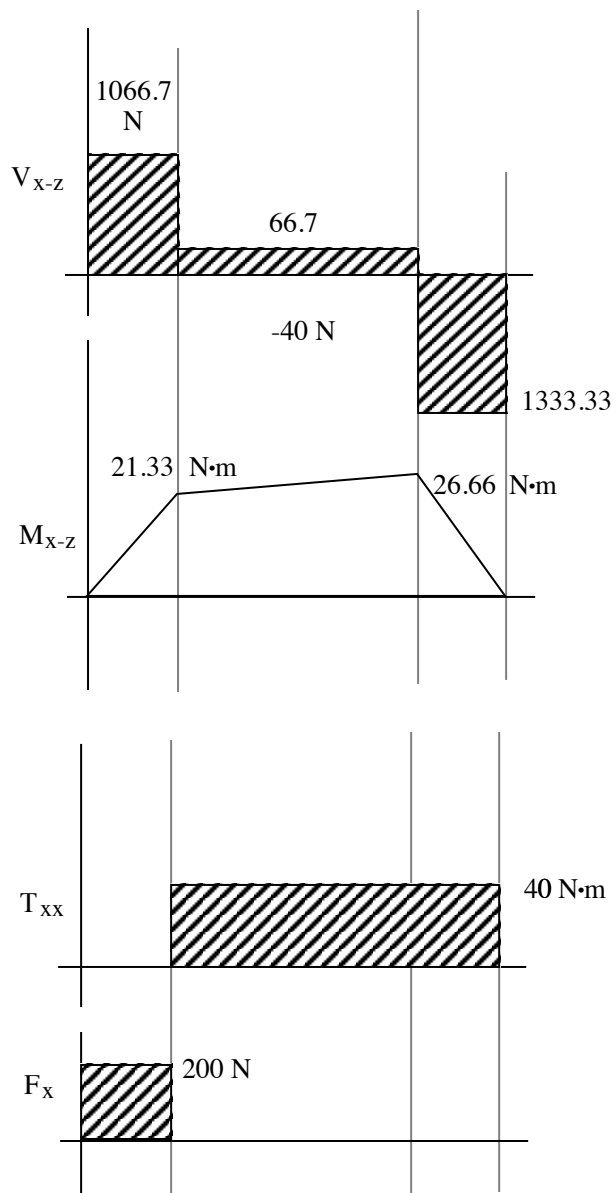

SOLUTION (2.59)

Known: A shaft has two bevel gears, and neither end of the shaft is connected to another component. The gear loads are known except for the transmitted force on one bevel gear.

Find: Draw axial load, shaft torque, shear force, and bending moment diagrams for the shaft.

Schematic and Given Data:

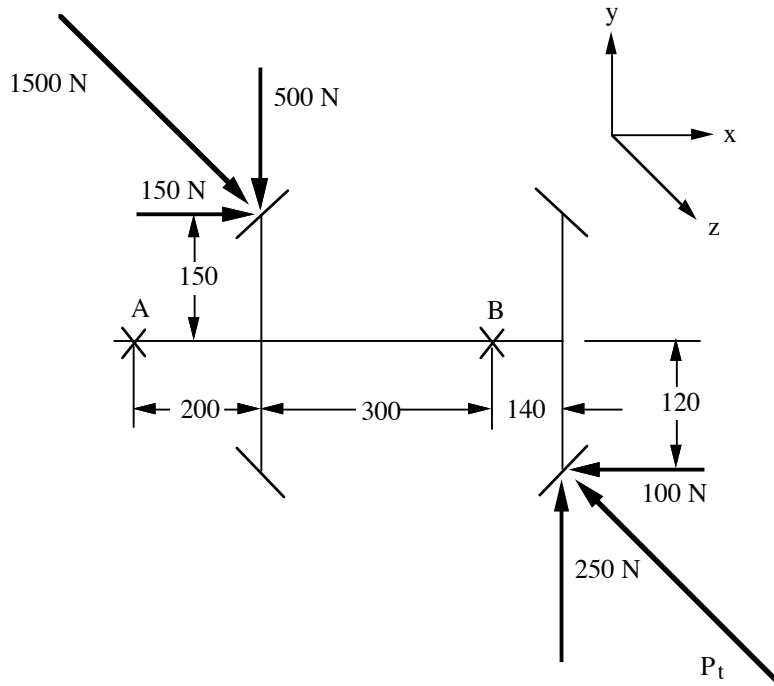

Assumptions:

1. The weight of the components is negligible.
2. The bearing at A carries all the thrust load.

Analysis: A free body diagram of the shaft with two bevel gears is:

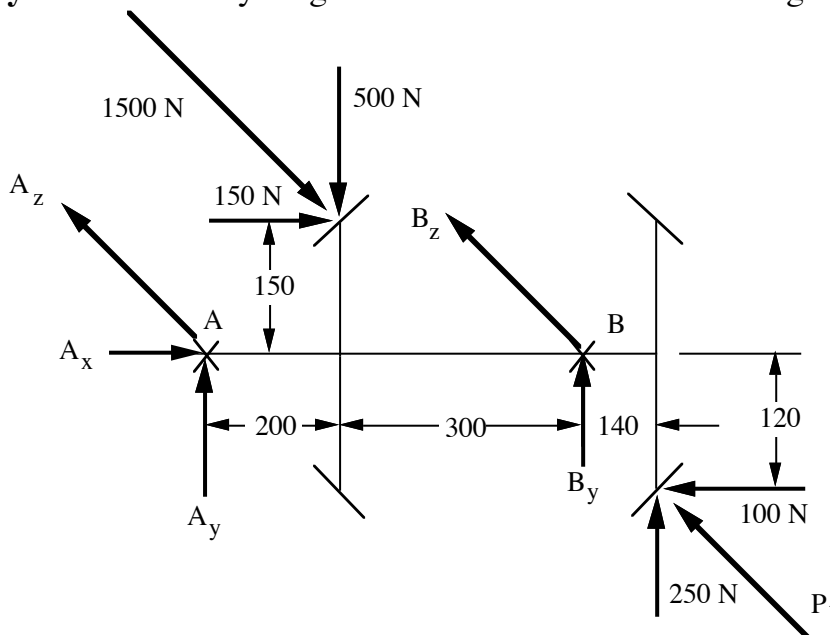

From force equilibrium:

1. $\sum M_{xx} = 0 : -(120)P_t + (1500)(150) = 0; P_t = 1875 \text{ N}$
2. $\sum F_x = 0 : A_x + 150 - 100 = 0; A_x = -50 \text{ N}$
3. $\sum M_{yA} = 0 : (1500)(200) - (B_z)(500) - (640)P_t = 0; B_z = -1800 \text{ N}$
4. $\sum F_z = 0 : A_z - 1500 - 1800 + 1875 = 0; A_z = 1425 \text{ N}$
5. $\sum M_{zA} = 0 : 150(150) + 500(200) - B_y(500) - 250(640) + 100(120) = 0;$
 $B_y = -51 \text{ N}$
6. $\sum F_y = 0 : A_y - 500 + B_y + 250 = 0; A_y = 301 \text{ N}$

The answers are:

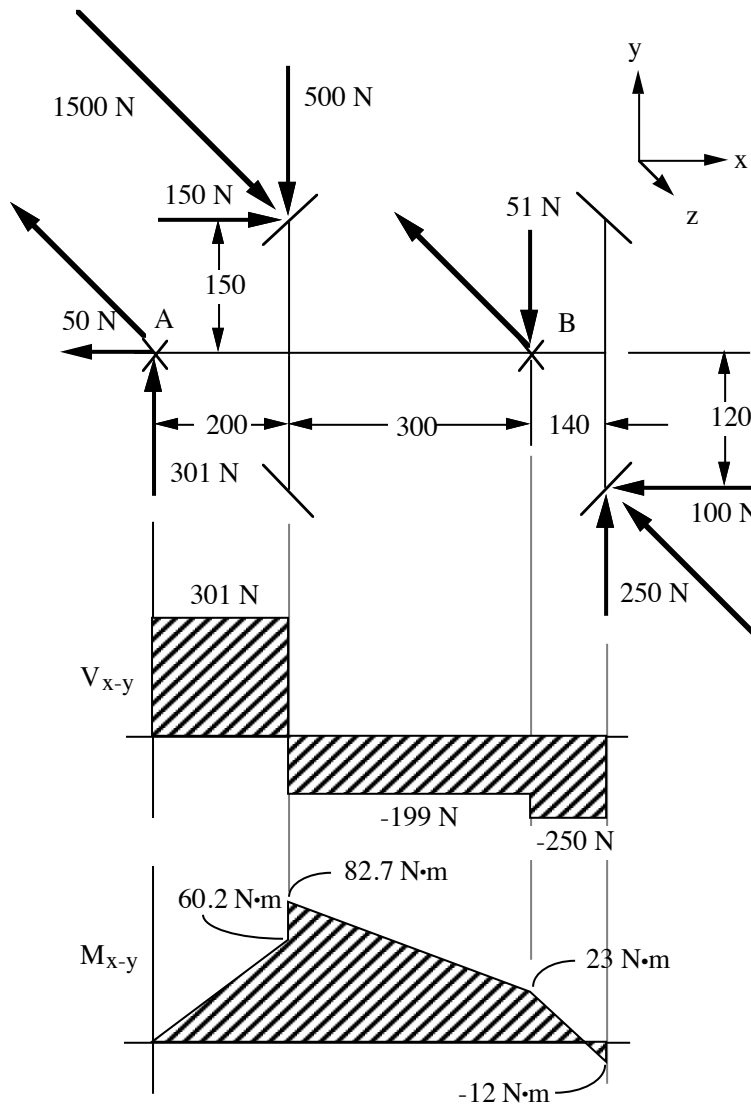

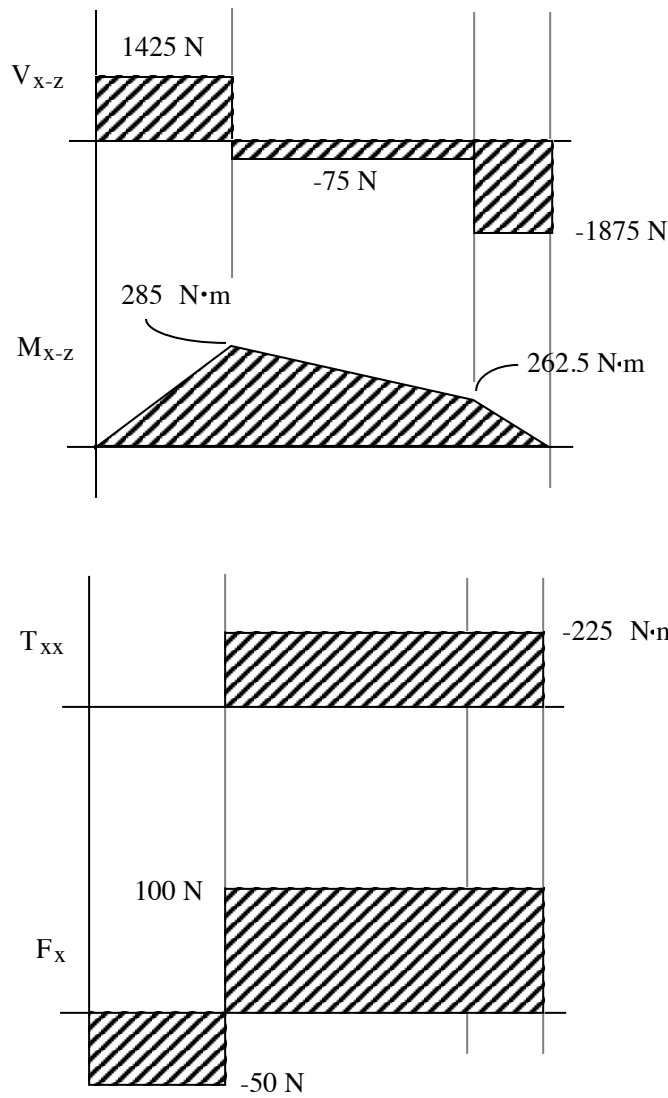

SOLUTION (2.60)

Known: A static force, F , is applied to the tooth of a gear that is keyed to a shaft.

Find: Identify the stresses in the key, and write an equation for each. State the assumptions, and discuss briefly their effects.

Schematic and Given Data:

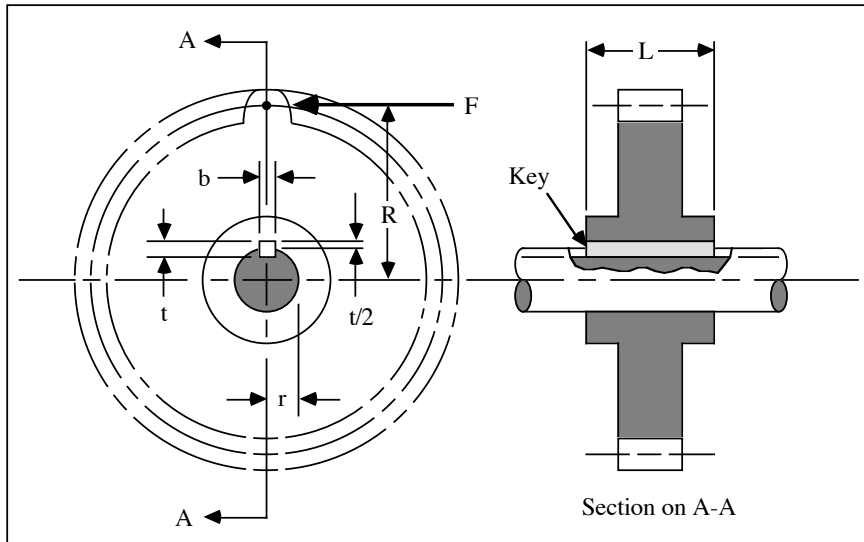

Assumption: The compressive forces on each side of the key are uniform.

Analysis:

1. Compression on key sides

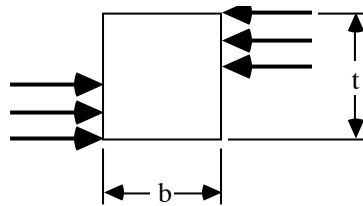

$$(\sigma_c \cdot L \cdot \frac{t}{2})r \approx FR ;$$

Hence, $\sigma_c \approx \frac{2FR}{(L)(t)(r)}$ or more precisely,

$$\sigma_c L \cdot \frac{t}{2} (r - \frac{t}{4}) = FR$$

$$\text{so, } \sigma_c = \frac{2FR}{Lt (r - t/4)}$$

2. Key shear

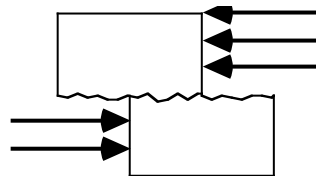

$$\tau (bL)r = FR ; \text{ hence, } \tau = \frac{FR}{bLr}$$

Comment: The compressive forces on each side of the key will most probably not be uniform because of key cocking.

SOLUTION(2.61)

Known: A screw with a square thread is transmitting axial force F through a nut with n threads engaged.

Find: Identify the types of stresses in the threaded portion of the screw and write an equation for each. State the assumptions made, and discuss briefly their effect.

Schematic and Given Data:

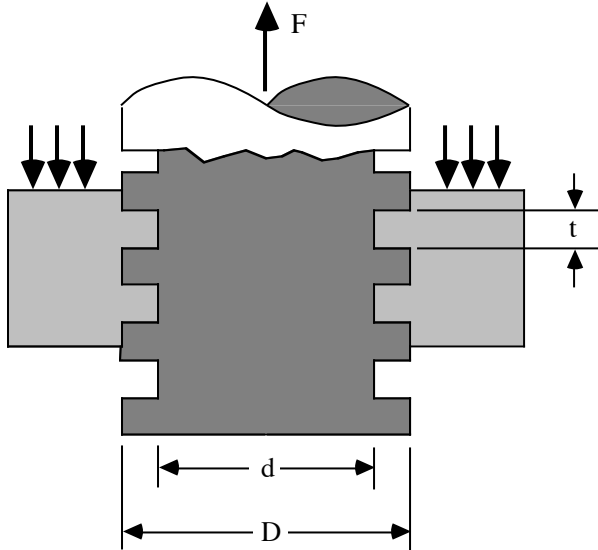

Assumption: The assumptions will be stated in the analysis section.

Analysis:

1. Compression at interface. Assuming uniform stress distribution, we have

$$\sigma = \frac{F}{\pi(D - d)n}$$

(The bending of the thread would tend to concentrate the stress toward the inside diameter and also produce a tensile stress at the thread root. Geometric inaccuracy may concentrate the load at one portion of a thread.)

2. Shear at the base of threads. Assuming uniform distribution of τ across the cylindrical failure surface, we have

$$\tau = \frac{F}{\pi d n t}$$

(The stress concentration would create a higher stress in the thread root. The effect of thread helix angle is neglected.)

SOLUTION (2.62new)

Known: A force P is applied as shown at the end of a thin walled, metal, cylindrical container that is open on the right end and closed on the left end. The container has a diameter of 3 inches and is 6 inches long.

Find: Sketch the force flow lines. Use the force flow concept to locate the critical sections and/or critical surfaces for the container.

Schematic and Given Data:

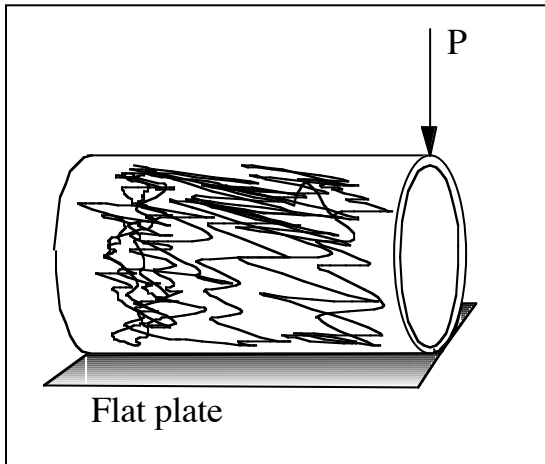

Assumptions:

1. The force P will not permanently deform the cylinder.
2. The left end of the cylinder is stiff compared to the right end.
3. The flat plate is thick and will remain flat and will experience negligible elastic deformation compared to the right end of the cylinder; e.g., the flat plate is relatively rigid and will not deflect in bending.
4. The material is uniform in elasticity and strength.

Analysis: The right end will deform elastically under the load with a small amount of force flowing toward the left end as the force P increases. The two critical locations are at the periphery of the open end of the cylinder 90 degrees from the force P where the bending moment (stress) is highest. A simple experiment would establish failure points.

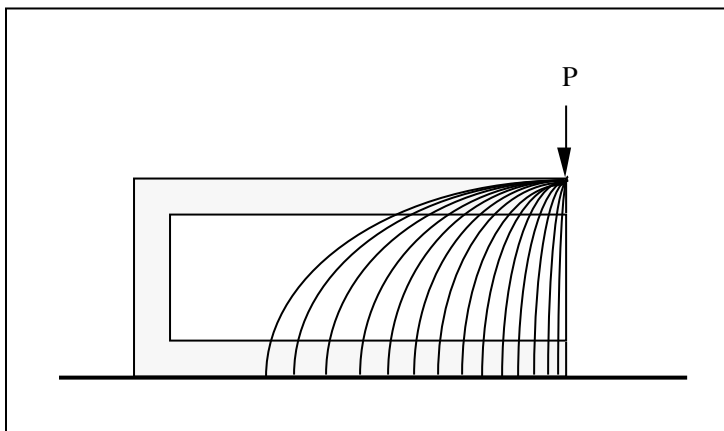

Comment: An experiment with a thin walled, cylindrical container, open at one end and closed on the other end could also be conducted to obtain a better estimate of the length of an equivalent ring (no closed end). With the deflection characteristics of an equivalent ring, i.e., the force deflection curve (ring spring constant), a spring model comprised of multiple rings could be developed and an analysis could be employed to study the load sharing along the length of the container. Equations for the deflection of various cylindrical rings are well known. For example, see Roark, "Formulas for Stress and Strain".

SOLUTION (2.63)

Known: A total gas force F is applied to the top of a piston.

Find:

- (a) Copy the drawing and sketch the force paths through the piston, through the piston pin, and into the connecting rod.
- (b) Identify the stresses in the piston pin and write an equation for each. State the assumptions made, and discuss briefly their effect.

Schematic and Given Data:

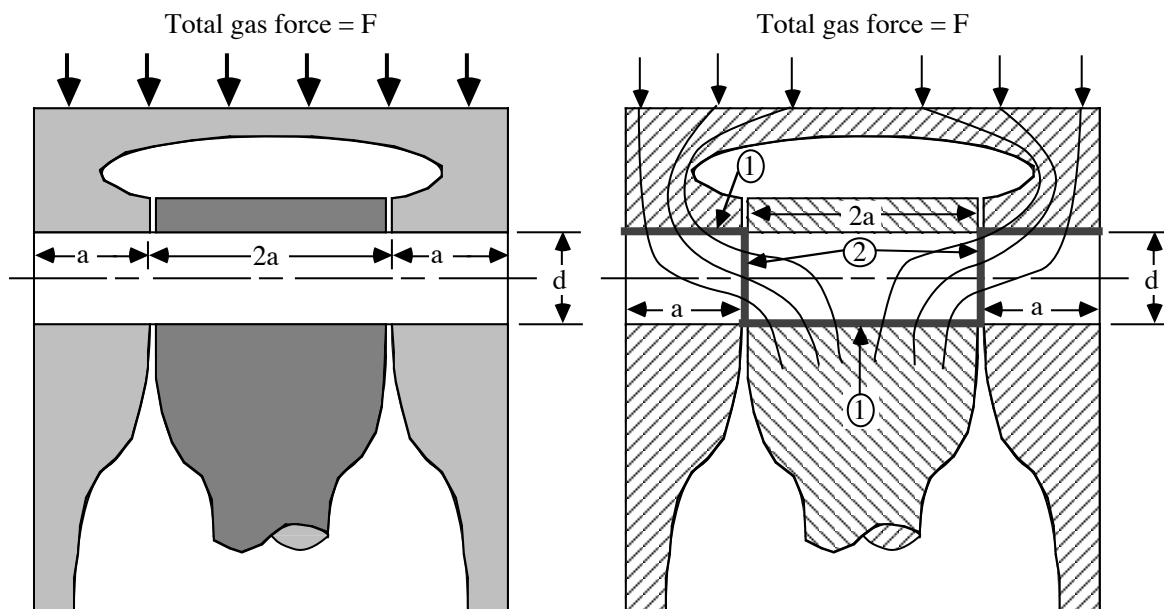

Assumption: The assumptions are stated in the analysis section.

Analysis:

1. Compression with piston and with rod: $\sigma = \frac{\text{Force}}{\text{Projected area}} = \frac{F^*}{2ad}$ ■
2. Transverse shear stress, $\tau = \frac{2F^{\Delta}}{\pi d^2}$ (for a solid pin) ■
3. Bending of pin (stresses depend on fit and rigidity of the members.)

* Assumes uniform axial distribution of stress which would not be strictly true due to pin bending.

Δ Assumes uniform stress distribution. Actual stresses may be greater at top and bottom.

SOLUTION (2.64)

Known: A force P is applied to an engine crankshaft by a connecting rod. The shaft is supported by main bearings A and B. Torque is transmitted to an attached member through flange F.

Find:

- (a) Draw the shaft, and show all loads necessary to place it in equilibrium as a free-body.
- (b) Starting with P and following the force paths through the shaft to the flange, identify the locations of potentially critical stresses.
- (c) Making appropriate simplifying assumptions, write an equation for each.

Schematic and Given Data:

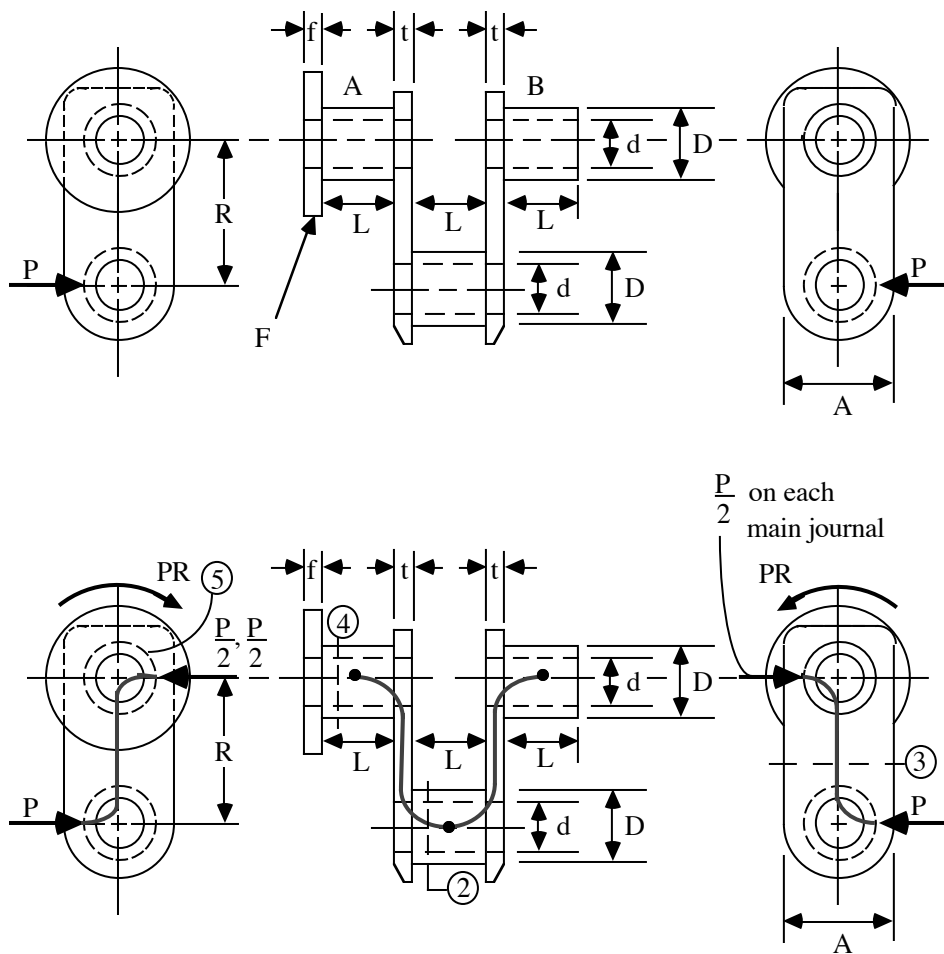

Analysis:

1. Where " P " is applied to the crankpin, the compressive stress (assuming uniform stress distribution) is given by:

$$\sigma = \frac{P}{\text{Projected Area}} = P/DL$$

2. The shear stress at section 2 (assuming uniform stress distribution) is:

$$\tau = \frac{P}{2\pi(D^2 - d^2)/4} : \tau = \frac{2P}{\pi(D^2 - d^2)}$$

3. The shear stress at section 3 (assuming a uniform distribution): $\tau = P/2tA$

4. The torsional stress at section 4 (neglecting stress concentration):

$$\tau = \frac{T_c}{J} = \frac{(PR)(D/2)}{\frac{\pi}{32}(D^4 - d^4)} = \frac{16PRD}{\pi(D^4 - d^4)}$$

5. The shear stress at cylindrical section 5:

$$\tau = \frac{T}{\pi D f (D/2)} = \frac{2PR}{\pi D^2 f}$$

6. Bending stresses are also present, the magnitudes of which depend on rigidities of the shaft and associated components, and on the fits between these components.

SOLUTION (2.65)

Known: In Figure P2.65, all the joints are pinned and all links have the same length L and the same cross-sectional area A . The central joint (pin) is loaded with a force P .

Find: Determine the force in the bars.

Schematic and Given Data:

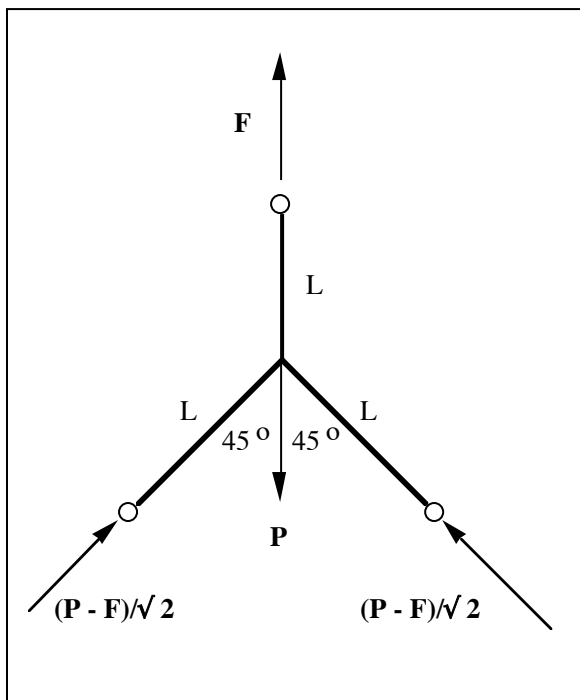

Assumptions:

1. The weight of the members are negligible.
2. Buckling will not occur in the lower links.

Analysis:

1. Let F be the tensile force in the upper link.
2. From $\Sigma F_{\text{vertical}} = 0$, the lower link forces are $(P-F)/\sqrt{2}$. ■

SOLUTION (2.66)

Known: We are to repeat Problem 2.65 except that the top link has a cross-sectional area of A , and the two lower links have a cross-sectional area of A' . All the joints are pinned and all links have the same length L . The central joint (pin) is loaded with a force P .

Find: Determine (a) the force in the bars, and (b) the ratio A/A' that will make the force in all the links numerically equal.

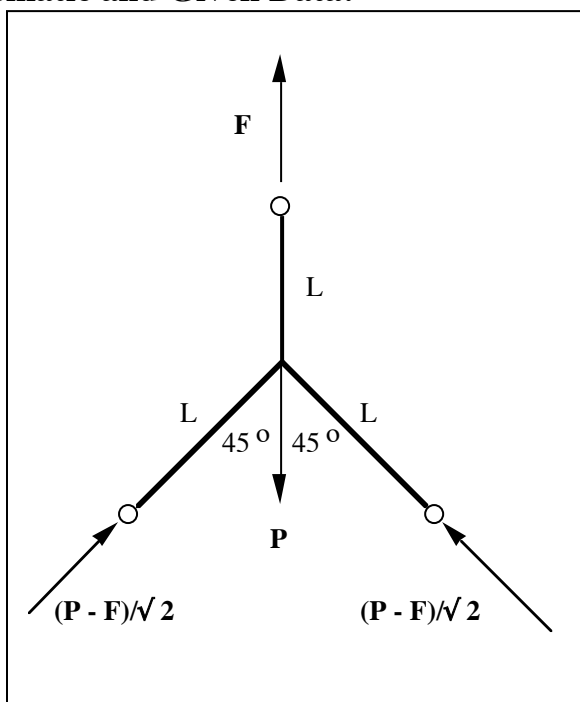
Schematic and Given Data:**Assumptions:**

1. The weight of the members are negligible.
2. Buckling will not occur in the lower links.

Analysis:

1. Let F be the tensile force in the upper link. Then from $\Sigma F_{\text{vertical}} = 0$, the lower link forces are $(P-F)/\sqrt{2}$. ■
2. The upper link has a cross sectional area A , and the lower links each have a cross sectional area A' .
3. The force P causes the center pivot to deflect downward. We define the deflection as δ -- see the figure below.

4. Since the upper member is subjected to the axial tension force, F , we can calculate the deflection of the upper member as $\delta_{\text{upper}} = FL/AE$.
5. Since the each lower member is subjected to the axial tension force, $(P-F)/\sqrt{2}$, we can calculate the deflection of each lower member as $\delta_{\text{lower}} = [(P-F)/\sqrt{2}]L/(A'E)$.

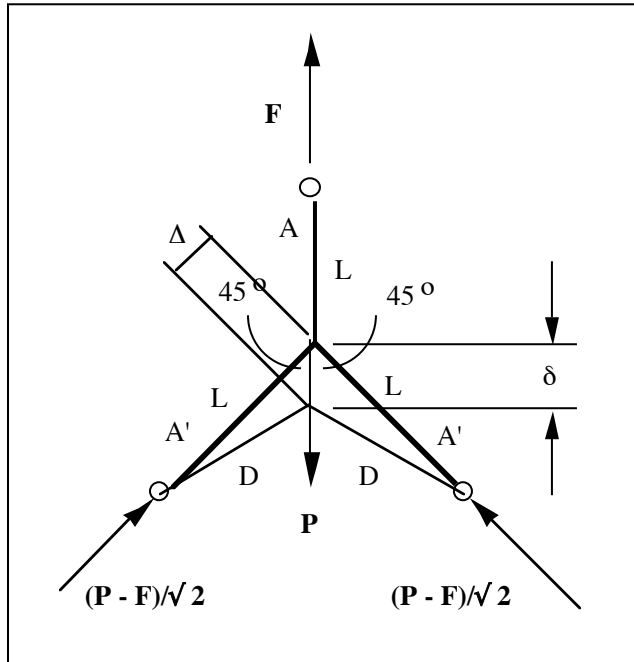

6. From the above diagram, we have $\cos 45^\circ = \Delta/\delta = 1/\sqrt{2}$.
7. If the links carry equal loads, then $(P-F)/\sqrt{2} = F$, or $F = \frac{P}{\sqrt{2}+1}$
8. Combining equations shows that $A'/A = \sqrt{2}$. ■

SOLUTION (2.67)

Known: A "T" bracket, attached to a fixed surface by four bolts, is loaded at point E.

Find:

- (a) Copy the drawing and sketch paths of force flow going to each bolt.
- (b) Determine the division of load among the four bolts.

Schematic and Given Data:

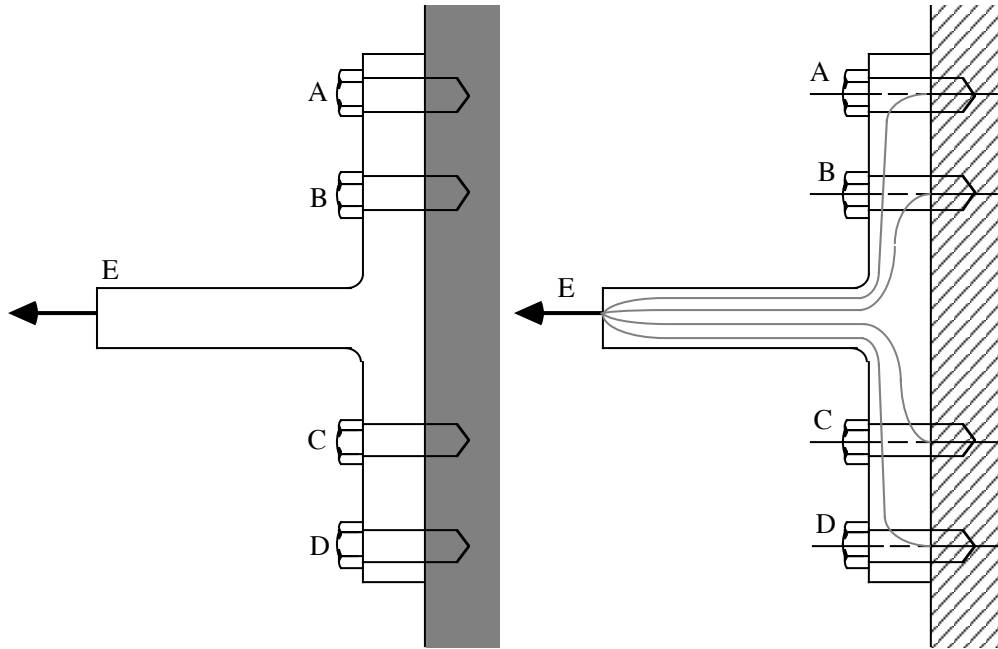

Assumptions

1. The T-bracket deflection is negligible.
2. The stiffness between point E and the plate through bolts B and C is twice the stiffness between point E and the plate through bolts A and D.

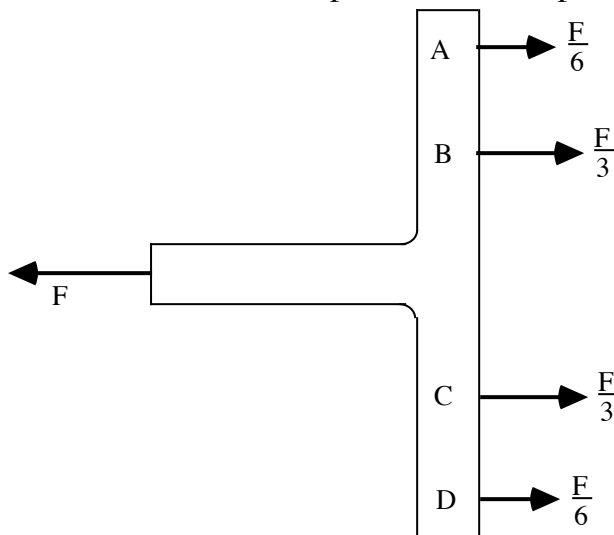

Analysis:

1. The force flow is shown in the above schematic.
2. If all "springs" deflect equally, bolts "B" and "C" each carry twice the load of bolts "A" and "D".

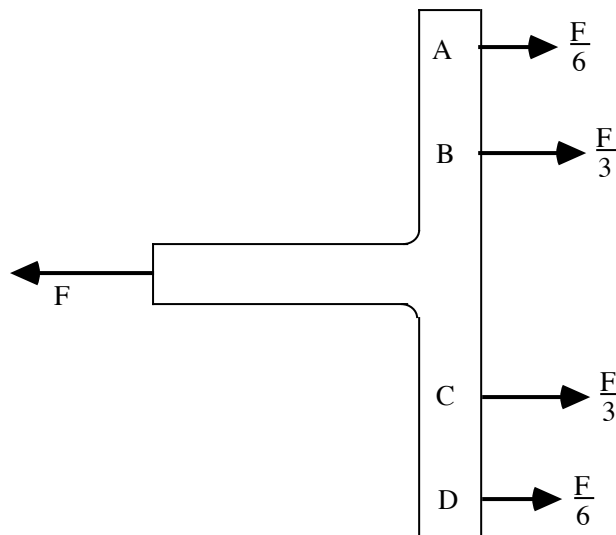
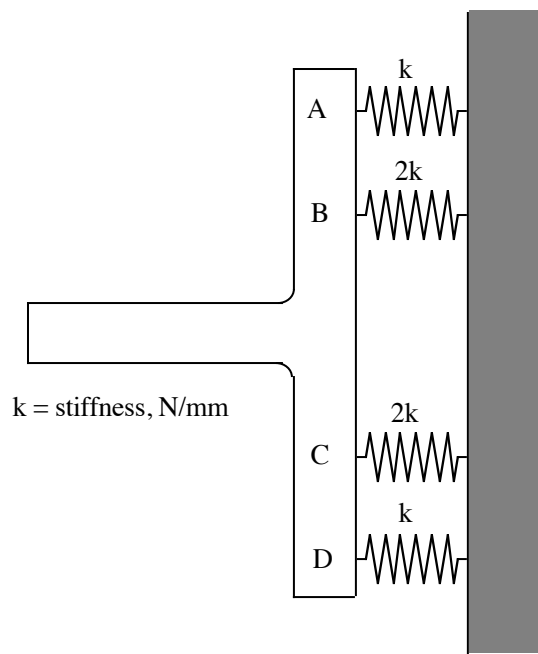

SOLUTION (2.68)

Known: A stiff horizontal bar, supported by four identical springs, is subjected to a known center load.

Find: Determine the load applied to each spring.

Schematic and Given Data:

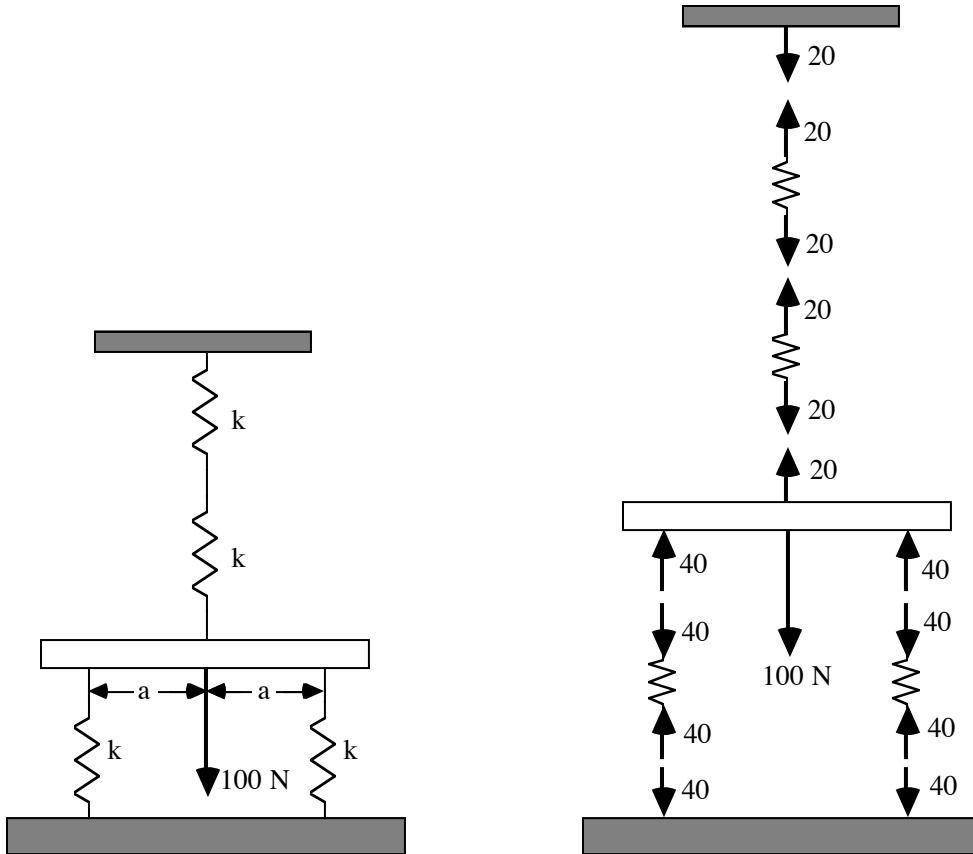

Assumption: The k of the horizontal bar is much greater than the k of the springs.

Analysis:

1. The upper springs each deflect only half as much as the lower springs, hence they carry only half as much load.
2. Let L = load carried by each lower spring. Then,
 $2L + L/2 = 100 \text{ N}$ and $L = 40 \text{ N}$
3. In summary, the lower springs carry 40 N, the upper springs 20 N. ■

SOLUTION (2.69)

Known: A horizontal nonrigid bar with spring constant k is supported by four identical springs each with spring constant k . The bar is subjected to a center load of 100N.

Find: Determine the load applied to each spring.

Schematic and Given Data:

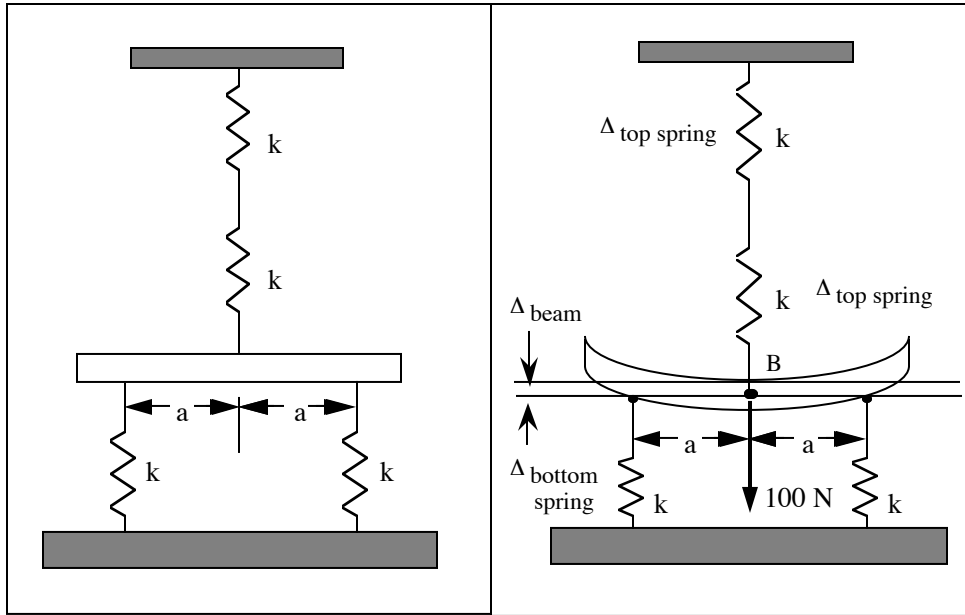

Assumption: The k of the horizontal bar is equal to the k of the springs.

Analysis:

1. The deflection of the two upper springs added together minus the deflection of the beam equals the deflection of each lower spring; i.e., $(\Delta_{\text{top spring}} + \Delta_{\text{top spring}}) - \Delta_{\text{beam}} = \Delta_{\text{bottom spring}}$.
2. From a free body diagram of the loaded beam, where F is the force in the upper springs and P is the force in each lower springs, we have, $F + 2P = 100 \text{ N}$.
3. Also, $\Delta_{\text{top spring}} = F/k$, $\Delta_{\text{bottom spring}} = P/k$, and $\Delta_{\text{beam}} = (100 - F)/k$.
4. Combining the equations and solving yields $F = 42.8 \text{ N}$ and $P = 28.6 \text{ N}$.
5. In summary, the lower springs carry 28.6 N , the upper springs 42.8 N . ■

SOLUTION (2.70)

Known: A "T" bracket, attached to a fixed surface by four bolts, is loaded at point E.

Find: Determine the maximum force F that can be applied to the bracket: (a) if the bolts are brittle and each one fractures at a load of 6000 N , (b) if the bolts are ductile and each bolt has a yield strength of 6000 N .

Schematic and Given Data:

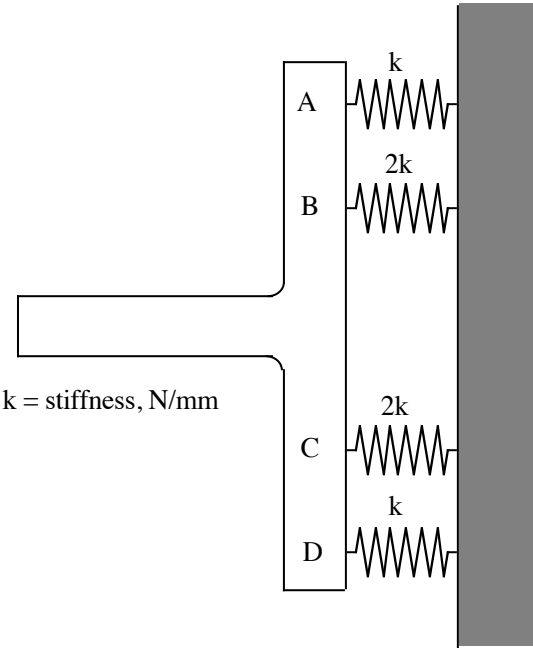
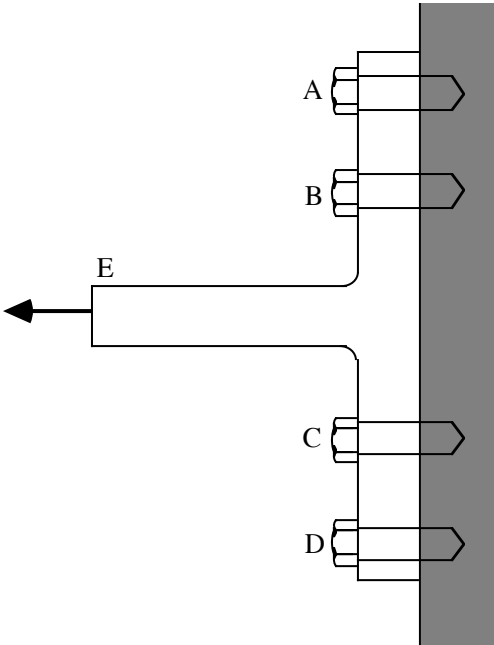

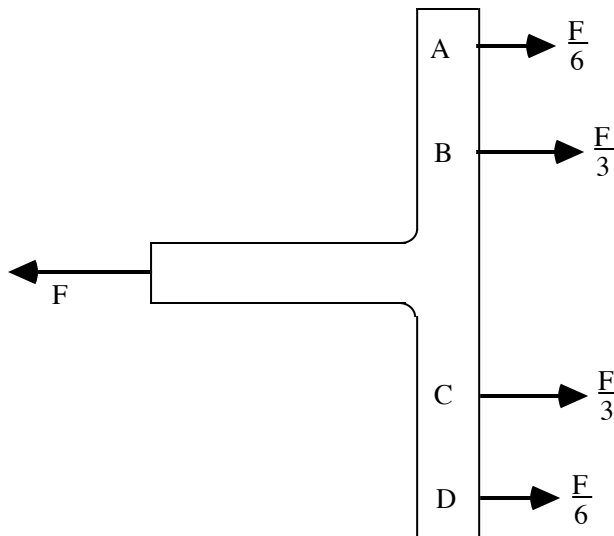

Assumptions:

1. The T-bracket deflection is negligible.
2. The stiffness between point E and the plate through bolts B and C is twice the stiffness between point E and the plate through bolts A and D.

Analysis:

- (a) Bolts "B" and "C" each carry $F/3$. They fracture at $F/3 = 6000$ N; hence maximum bracket force is 18,000 N. ■
- (b) Bolts "B" and "C" begin to yield at $F = 18,000$ N, but permit sufficient elongation to allow "F" to be increased with bolts "A" and "D" also yielding; hence the maximum bracket force is 24,000 N. ■

SOLUTION (2.71--alternate problem with different yield strengths)

Known: Two plates are joined with straps and a single row of rivets (or bolts). Plates, straps, and rivets are all made of ductile steel having yield strengths in tension, compression, and shear of 300, 300, and 170 MPa respectively.

Find:

- (a) Calculate the force F that can be transmitted across the joint per pitch P, of joint width, based on the rivet shear strength.
- (b) Determine minimum values of t, t', and P that will permit the total joint to transmit this same force (thus giving a balanced design).
- (c) Determine the efficiency of the joint (ratio of joint strength to strength of a continuous plate).

Schematic and Given Data:

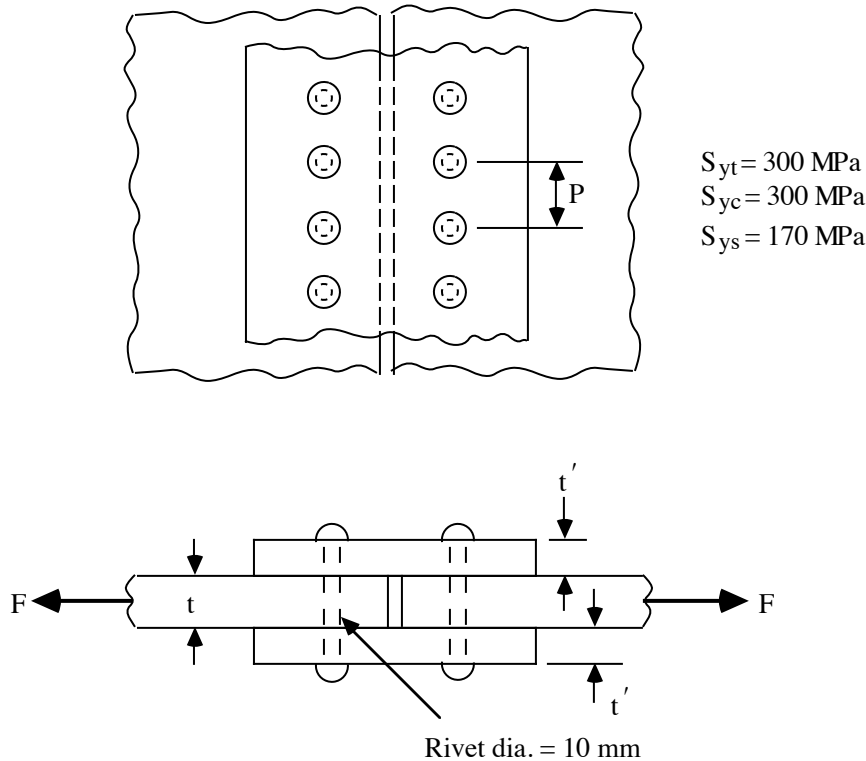

Assumption: The frictional forces between the plates and straps are negligible.

Analysis:

- (a) Each pitch involves transmitting force "F" through 1 rivet in double shear:

$$F = 2 \left(\frac{\pi d^2}{4} \right) \cdot S_{ys} = 2 (25\pi \text{ mm}^2)(170 \text{ MPa}) = 26,700 \text{ N} \quad \blacksquare$$

- (b) For plate and strap to have equal tensile strength and equal compressive strength (at rivet interface), $t = 2t'$.

The compressive load carrying capacity (at rivet interface) is

$$F = \text{Projected area} \cdot S_{yc} :$$

$$26,700 \text{ N} = 10 t \text{ mm}^2 \cdot 300 \text{ MPa. Hence, } t = 8.90 \text{ mm; } t' = 4.45 \text{ mm.} \quad \blacksquare$$

The tensile load carrying capacity (at rivet interface) is $F = (P - 10) t \cdot S_{yt} :$

$$26,700 \text{ N} = (P - 10)(8.90) \text{ mm}^2 \cdot 300 \text{ MPa}$$

$$P = 20 \text{ mm} \quad \blacksquare$$

- (c) Efficiency = $\frac{\text{Joint strength}}{\text{Strength of a continuous plate}} = \frac{26,700}{S_{yt}(t)(P)} =$

$$\frac{26,700}{(300 \text{ MPa})(8.90 \text{ mm})(20 \text{ mm})} = 0.50 = 50\% \quad \blacksquare$$

SOLUTION (2.71)

Known: Two plates are joined with straps and a single row of rivets (or bolts). Plates, straps, and rivets are all made of ductile steel having yield strengths in tension, compression, and shear of 284, 284, and 160 MPa respectively.

Find:

- (a) Calculate the force F that can be transmitted across the joint per pitch P , of joint width, based on the rivet shear strength.
- (b) Determine minimum values of t , t' , and P that will permit the total joint to transmit this same force (thus giving a balanced design).
- (c) Determine the efficiency of the joint (ratio of joint strength to strength of a continuous plate).

Schematic and Given Data:

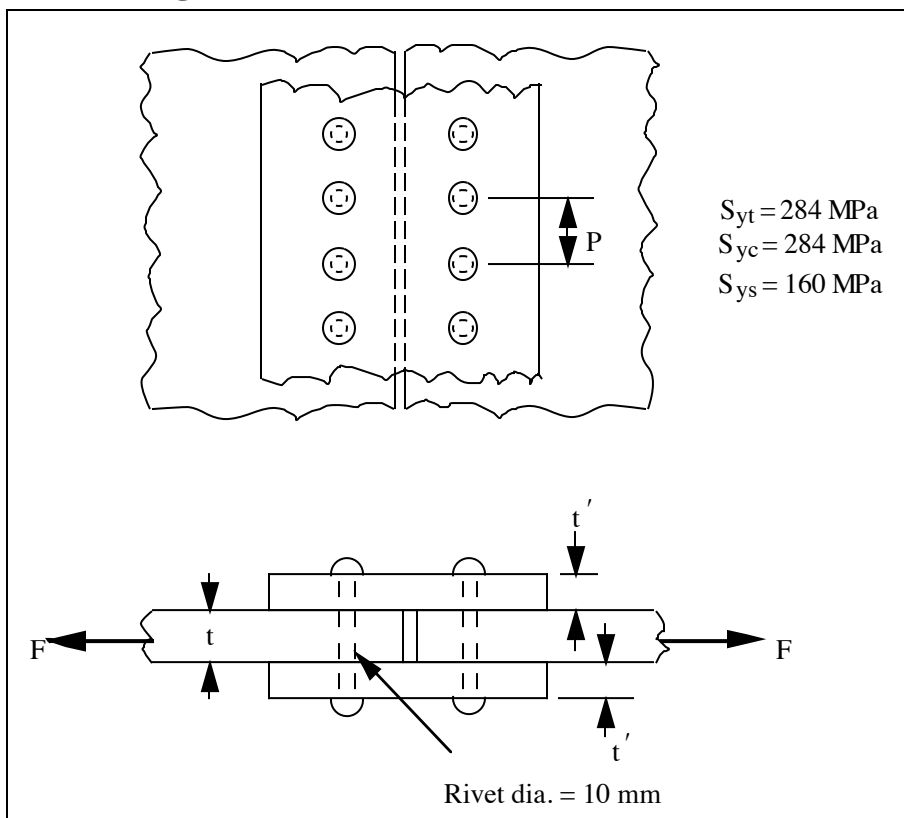

Assumption: The frictional forces between the plates and straps are negligible.

Analysis:

- (a) Each pitch involves transmitting force " F " through 1 rivet in double shear:

$$F = 2 \left(\frac{\pi d^2}{4} \right) \cdot S_{ys} = 2 (25\pi \text{ mm}^2)(160 \text{ MPa}) = 25,133 \text{ N} \quad \blacksquare$$

- (b) For plate and strap to have equal tensile strength and equal compressive strength (at rivet interface), $t = 2t'$.

The compressive load carrying capacity (at rivet interface) is

$$F = \text{Projected area} \cdot S_{yc}$$

$$25,133 \text{ N} = 10 t \text{ mm}^2 \cdot 284 \text{ MPa. Hence, } t = 8.85 \text{ mm; } t' = 4.425 \text{ mm.}$$

■

The tensile load carrying capacity (at rivet interface) is $F = (P - 10) t \cdot S_{yt}$:

$$25,133 \text{ N} = (P - 10)(8.85) \text{ mm}^2 \cdot 284 \text{ MPa.}$$

$$\text{Hence, } P = 20 \text{ mm.}$$

■

$$(c) \text{ Efficiency} = \frac{\text{Joint strength}}{\text{Strength of a continuous plate}} = \frac{25,133}{S_{yt}(t)(P)} =$$

$$\frac{25,133}{(284 \text{ MPa})(8.85 \text{ mm})(20 \text{ mm})} = 0.50 = 50\%$$

■

SOLUTION (2.72)

Known: Plates of known thickness are butted together and spliced using straps and rivets. A double-riveted joint is used. Tensile, compression, and shear strengths of all materials are known.

Find: Determine the pitch, P, giving the greatest joint strength. Comment on how this compares with the strength of a continuous plate.

Schematic and Given Data:

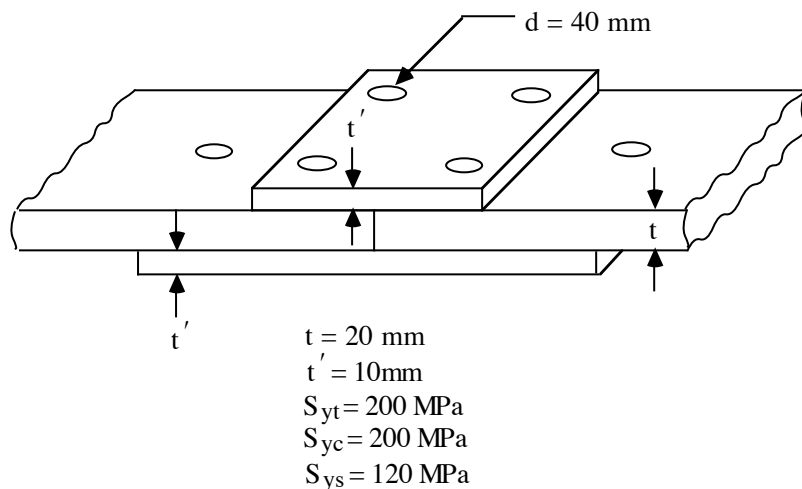

Assumption: The friction forces between plates and straps are negligible.

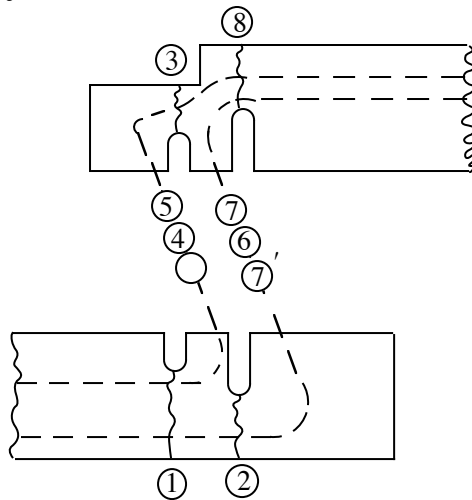
Analysis:

1. Failure of both force paths together
 Failure load at 1: $F = (P - 40)(20)(200)$
 But 8 is more critical: $F = (P - 80)(20)(200)$ ---(a)
2. Failure of each path individually
 Outer row of rivets:
 At 3: $F = (P - 40)(10)(200)$
 At 4: $F = \pi(20)^2 120 = 150,796 \text{ N}$ (single shear)
 At 5: $F = (40)(10)(200) = 80,000 \text{ N}$
 The inner row of rivets:
 At 2: $F = (P - 80)(20)(200)$
 At 6: $F = 2\pi(20)^2 120 = 301,592 \text{ N}$ (double shear)
 At 7: $F = (40)(20)(200) = 160,000 \text{ N}$ (7' is the same)
3. The outer row will have a strength of 80,000 N if,
 $2000(P - 40) \geq 80,000$
 or $P \geq 80$ ■
4. The inner row will have a strength of 160,000 N if,
 $4000(P - 80) \geq 160,000$
 or, $P \geq 120$
5. For 8 to have a strength of
 $80,000 + 160,000 = 240,000 \text{ N}$:
 $(P - 80)(20)(200) = 240,000$, or $P = 140 \text{ mm}$ ■
6. Continuous plate strength = $P(20)(200) = (140)(20)(200) = 560,000 \text{ N}$
7. Joint strength = $\frac{240}{560} = 43\%$ of continuous plate strength ■