

# Chapter 3

## Organisational Strategy, Information Systems and Competitive Advantage

### Book Content

[Study Questions](#)

Answers to the study questions

[Ethics Guide](#)

Answers to the questions in the ethics guide—Yikes! Bikes

[The Guide](#)

Answers to the questions in the guide—your personal competitive advantage

[Using Your Knowledge](#)

Answers to questions in using your knowledge

[Collaboration Exercise 3](#)

Answers to questions in collaboration exercise 3

[Case Study 3](#)

Answers to questions in the case study—competitive advantage at National Australia Bank

[Return to start of document](#)

Copyright © 2016 Pearson Australia (a division of Pearson Australia Group Pty Ltd)  
9781486019281/Kroenke/Experiencing MIS/4e

# Book Content

## **Study questions**

- Q1 How does organisational strategy determine information systems structure?
- Q2 What five forces determine industry structure?
- Q3 What is competitive strategy?
- Q4 How does competitive strategy determine value chain structure?
- Q5 How do value chains determine business processes and information systems?
- Q6 How do information systems provide competitive advantage?

## **Ethics guide—Yikes! Bikes**

### Goals

- Sensitise the students to the fact that a competitive strategy is not just an academic topic. Changing competitive strategy has dramatic impacts on personnel and company culture.
- Understand practical applications of business reports.
- Explore ethical questions concerning communication about sensitive topics.

### Background and presentation strategies

Ownership changes are always traumatic. In my experience, new management always says, 'We're going to make few significant changes' (unless the company has been in dire straits), but invariably major changes are on the way. This guide illustrates the uncomfortable position many managers face when they possess knowledge that cannot be communicated to everyone in the company.

- As a manager, you will sometimes have information that you are not supposed to communicate to employees. If an employee asks you directly about that information, you can either divulge it or lie. Which would you choose? What are the consequences of either choice?
- Is there an alternative between inappropriately divulging information and lying? What is it? What disadvantages does that alternative have?
- In general, what are the consequences for the organisation's culture of moving from a differentiation strategy to a low-cost strategy?
- In general, what are the consequences for the organisation's culture of moving from a low-cost strategy to a differentiation strategy?

### Suggested responses for discussion questions

*1. In your opinion, did the new owners take any illegal actions? Is there evidence of crime in this scenario?*

No. There is no evidence of crime. They own the company and can change the competitive strategy and culture as they see fit.

*2. Consider the ethics of the statement that Parks made to all the employees. Using both the categorical imperative and utilitarianism, assess the ethics of that statement. If you were to question her about the ethics of her statement, how do you think she would justify herself?*

[Return to start of document](#)

She's lying. If you believe that any lie is unethical (Kant's categorical imperative) then her behaviour is unethical. But what should she do? If she announces that they plan an across-the-board staff reduction, work and productivity will cease for that day ... and maybe much longer. Plus, she can make no specific statement about who will be cut, so being more forthright would just raise employee anxiety, and unnecessarily so for 90 per cent of the employees. Therefore you might say she is maximising 'utility' (minimising negative side effects), in accordance with utilitarianism. Ask students how they might change her opening remarks to make them more honest without causing panic.

*3. What do you think Parks will tell the founder if he calls her as a result of your conversation with him? Does he have any legal recourse? Is Major Capital's behaviour towards him unethical? Why, or why not?*

It depends on her mood. She could tell him that he no longer owns the company and to keep his thoughts to himself. Or she could listen, make some empty statement, and then do what she plans to do anyway. Unless there was something specific about no staff reductions in the purchase agreement (unlikely), he has no legal recourse. Major Capital's behaviour doesn't appear to be unethical. The founder asked them to take care of the employees and their change doesn't allow them to meet his request. You had better hope, however, that he didn't tell Ms Parks that you called him. She might be vindictive.

*4. Parks is going to use the information to perform staff cuts. What do you think about her rationale? Ethically, should she consider other factors, such as number of years of service, past employee reviews or other criteria?*

Major Capital is implementing a change in competitive strategy. The company wants Yikes! to be a low-cost vendor, so it needs to cut costs. Parks' plan may not be the most effective in terms of minimising employee stress, but she and Major Capital have every right to implement their strategy however they want. They own the show.

*5. How would you respond to Lori? What are the consequences if you tell her what you know? What are the consequences of lying to her? What are the consequences of saying something noncommittal? Consider both the categorical imperative and utilitarian perspectives in your response.*

Let's say that Lori is the most popular support rep because she spends a lot of time with the customer. But Parks has already revealed she considers people like Lori to be 'time wasters', so she's likely to be one of the first employees fired. Knowing that, you have to be very careful lest you end up as part of a wrongful termination lawsuit. Sad to say, but that's the reality. To respect your chain of command, you cannot tell her she's about to be fired. But you don't want to lie, either, lest Lori sue you when she does get fired (setting aside any moral or ethical issues). You have to say something noncommittal. It has to be true, but non-informative. Perhaps something like, 'Well, this is their first day. Let's wait and see what develops.' You might even say something like, 'I suspect change is in the air,' but if you do that, you encourage further conversation.

[Return to start of document](#)

6. *If you actually were in this situation, would you leave the company? Why, or why not?*

This answer has to be personal. It is worth asking the students to think about how they might behave if they were stuck in a job that they hated for some reason.

7. *In business school, we talk of principles such as competitive strategy as interesting academic topics. But, as you can see from the Yikes! case, competitive strategy decisions have human consequences. How do you plan to resolve conflicts between human needs and tough business decisions?*

This is a complex and difficult question. It really depends on how one views the responsibility an organisation has to its employees.

8. *How do you define 'job security'?*

The best definition that I've heard of job security is: 'Possess a marketable skill and the courage to use it.' Companies are legal entities, nothing more. No such entity will give you security.

Wrap up

Has the discussion of this guide changed student thinking in any way? In particular:

- What does a change in competitive strategy mean to employees?
- When a company changes ownership, what is a good posture for smart employees to take?
- How will you behave when you possess knowledge that you cannot disclose and someone asks you directly about it?
- What is job security, for you?

## ***The guide—your personal competitive advantage***

1. *Summarise the efforts you have taken thus far to build an employment record that will lead to job offers after graduation.*

Student answers will vary.

2. *Considering the first three principles in Table 3.5, describe one way in which you have a competitive advantage over your classmates. If you don't have such a competitive advantage, describe actions you can take to obtain one.*

Student answers will vary. The three principles from Table 3.5 are:

1. Create a new product or service
2. Enhance products or services
3. Differentiate products or services

This video may encourage discussion:

- Build Your Personal Brand and a Competitive Advantage with Social Media <[www.youtube.com/watch?v=1BqjZsL0aOU](http://www.youtube.com/watch?v=1BqjZsL0aOU)> accessed 31/03/2015.

[Return to start of document](#)

3. In order to build your network, you can use your status as a student to approach business professionals. Namely, you can contact them for help with an assignment or for career guidance. For example, suppose you want to work in banking and you know that your local bank has a customer information system. You could call the manager of that bank and ask him or her how that system creates a competitive advantage for the bank. You also could ask to interview other employees and go armed with the list in Table 3.5. Describe two specific ways in which you can use your status as a student and the list in Table 3.5 to build your network in this way.

Student answers may vary. A useful video is:

- Careers—Networking: tips from a graduate recruiter  
<[www.youtube.com/watch?v=CrpwTkM8yIE](http://www.youtube.com/watch?v=CrpwTkM8yIE)> accessed 31/03/2015.

4. Describe two ways that you can use student alliances to obtain a job. How can you use information systems to build, maintain and operate such alliances?

These websites will be useful for starting discussion:

- Networking In College: Build Your Network Before You Need It!  
<[www.youtube.com/watch?v=k46EGCLCs4g](http://www.youtube.com/watch?v=k46EGCLCs4g)> accessed 31/03/2015.
- Career Advice: Business Networking for Graduates  
<[www.youtube.com/watch?v=ZwclIqzIh2I](http://www.youtube.com/watch?v=ZwclIqzIh2I)> accessed 31/03/2015.

## **Using your knowledge**

1. Apply the value chain model to a retailer such as Target (<[www.target.com.au](http://www.target.com.au)>). What is its competitive strategy?

a. Describe how each of the primary value chain activities pertains to Target. Rank the importance of that activity to Target's success on a scale of 1 (low) to 5 (high). Justify your ranking.

**Inbound Logistics:** Defined as receiving, storing and disseminating inputs to the product. For Target, this value chain activity involves ordering, receiving and installing the goods and products that they retail in their stores. Target must ensure its inbound logistics keep stores stocked with merchandise. This value chain activity is important to Target and ranks very high (4)—without goods and products to sell, Target cannot be successful.

**Operations:** Defined as transforming inputs into the final product. For Target, this value chain activity involves selling to customers and collecting payment through its network of stores. Target's operations ensure a pleasing shopping experience with enticing, well-designed displays. This is the heart of Target's service, and is the most important value chain activity (5).

**Outbound Logistics:** Defined as collecting, storing and physically distributing the product to buyers. Target's outbound logistics ensure that customers can readily make their purchases; also, Target must provide after-sale service to its customers, especially regarding returns and defective products. This value chain activity is limited for Target, because once a customer has purchased an

[Return to start of document](#)

item at a store they take it away with them. Therefore, this value chain activity is least important (1/2).

**Marketing and Sales:** Defined as inducing buyers to purchase the product and providing a means for them to do so. Target uses advertising conveying its hip and stylish products at value prices to attract customers. This is a critically important value chain activity for Target (5). Target must make potential customers aware of its existence and the goods and products it provides and make it easy for customers to access its stores.

**Service:** Defined as assisting the customer's use of the product and thus maintaining and enhancing the product's value. This is a very important part of Target's value chain (4)—anything that enhances the customer's experience at Target will increase the likelihood that the customer will be a repeat customer.

*b. Describe how each support value chain activity pertains to Target. Rank the importance of that activity to Target's success on a scale of 1 (low) to 5 (high). Justify your ranking.*

**Procurement:** Defined as finding vendors, setting up contractual arrangements and negotiating prices. For Target, this activity involves sourcing the goods and products it sells in its stores. There are many options available and Target seeks to balance price with quality in its procurement activity. Target's competitive strategy is differentiation/focus. Target strives to have higher quality and more stylish products at reasonable prices in the discount department store segment of the consumer retail industry. This is an important support activity for Target (4).

**Technology:** Defined as research and development plus development of new techniques, methods and procedures. For Target, this is important as information systems can deliver efficiencies in a very competitive and low margin industry (4).

**Human Resources:** Defined as recruitment, compensation, evaluation and training of employees. This is an important support activity for Target as good staff enhance the customer's experiences at Target and will increase the likelihood that the customer will be a repeat customer; however, it is not critical to Target (3/4).

**Infrastructure:** Defined as general management, finance, accounting, legal and government affairs. This is a necessary activity for Target (3/4).

*c. Develop a diagram of two business processes that support the primary activities you identified as most important in part a. Use Figures 3.4 and 3.5 as a guide.*

Student responses will vary and will depend on their responses to part a. The diagrams should be based on Figures 3.4 and 3.5 and should focus on the primary activities rated highly in part a.

*d. Explain how each of the business processes in your answer to part c adds value to Target. How does the business process need to be designed to support Target's competitive strategy?*

[Return to start of document](#)

Sales and Marketing adds value by making prospective customers aware of Target's products as well as convincing customers to visit one of Target's stores (rather than one of its competitor's stores). This process supports Target's strategy by emphasising high quality at a low price. Other aspects of the marketing campaigns would include store locations and special offers available at a particular time.

Operations adds value by ensuring that Target stores provide an environment that enables its staff to sell to customers and collect payment in line with the overall company strategy. This activity is at the heart of Target's service and emphasises its key strategic approaches to its customers.

*e. How does Target's competitive strategy and the nature of its business influence the general characteristics of Target's information systems?*

Information systems deliver efficiencies in a very competitive and low margin industry. They are deployed in key areas of the business such as inbound logistics and procurement as well as at the point-of-sale. Particular areas of focus may be store inventory management and distribution.

*2. Apply the value chain model to an online business such as Red Balloon (<[www.redballoondays.com.au](http://www.redballoondays.com.au)>). What is its competitive strategy? Describe the tasks Red Balloon must accomplish for each of the primary value chain activities. How does Red Balloon's competitive strategy and the nature of its business influence the general characteristics of its information systems?*

Red Balloon's competitive strategy is differentiation/focus. Red Balloon is Australia and New Zealand's leading online gift retailer of 'experiences'. They focus on providing gifts that are amazing and memorable: 'And because life is the sum of our experiences, not our belongings, we know there's nothing more amazing and memorable than a Red Balloon experience.'

Red Balloon stresses amazing and memorable—different; but not necessarily low prices. They rely on their website to convey their enthusiastic, high-energy and high-drive image to attract customers. Inbound logistics are focused on having adequate stocks of different and exciting products available to fill customer wishes. Operations involves taking and filling orders rapidly, and its outbound logistics focuses on timely delivery to the customer. Service concentrates on providing amazing, memorable and different experiences to meet customer wishes. Red Balloon's information systems will emphasise online photographs to highlight their different products plus online ordering for immediate confirmation.

*3. Suppose you decide to start a business that recruits students for summer jobs. You will match available students with available jobs. You need to learn what positions are available and what students are available for filling those positions. In starting your business, you know you will be competing with local newspapers and websites. You will probably have other local competitors as well.*

*a. Analyse the structure of this industry according to Porter's five forces model.*

In this situation, the bargaining power of customers may be relatively strong. The customers (students) have other options to use to find summer jobs. The

[Return to start of document](#)



threat of substitution is probably pretty low because there will always be a strong demand by students for summer work. The bargaining power of suppliers (businesses that have a need for summer workers) is relatively strong because these employers have a variety of ways to reach the pool of students looking for summer work. The threat of new entrants is somewhat strong because other similar agencies, job boards, etc., can be easily established. Finally, rivalry among existing firms is probably fairly strong since there is a brief period of time during which this market segment is active (several weeks and months prior to the start of the summer break).

*b. Given your analysis in part a, recommend a competitive strategy.*

The analysis in part a suggests that it will be difficult to be profitable in this industry. Competing on the basis of cost alone seems problematic because some of the options available are free (or nearly free). To achieve success, a differentiation strategy within the segment of students seeking summer work seems advisable.

*c. Describe the primary value chain activities as they apply to this business.*

Inbound logistics refers to acquiring our raw materials (jobs) and organising them in some way that makes it easier to match student skills and interests with job opportunities and requirements. We need to make it easy for employers to contact us and provide information about job opportunities. Operations involves matching students and jobs so that the most successful placements can be made. Outbound logistics involves notifying the student of a job match and getting the student's job acceptance. Marketing and Sales involves building awareness of our service to the population of students who are our customers. Service involves providing information and support to students who have agreed to a job placement we have arranged for them.

*d. Describe a business process for recruiting students.*

Student answers will vary. This is a sample answer. As a marketing and sales technique, we utilise a skills and interests survey that determines the type of summer jobs a student is qualified for and capable of performing. Because of the quality and detail of our survey, we are able to achieve highly successful placements. Therefore, students are attracted to our service.

*e. Describe information systems that could be used to support the business process in part d.*

A web-based system could be used to administer the skills and interests survey to students in a convenient way.

*f. Explain how the process you described in part d and the system you described in part e reflect your competitive strategy.*

This business process and the way it is accomplished could be part of the way we distinguish ourselves from the competition. Possibly none of the others in the industry have such a comprehensive understanding of a student's skills and interests; therefore, we are better able to make successful placements that satisfy the employer and the student.

[Return to start of document](#)



4. Consider the two different bike rental companies in Table 3.4. Think about the bikes they rent. Clearly, the student bikes will be just about anything that can be ridden out of the shop. The bikes for the business executives, however, must be new, shiny, clean and in tip-top shape.

a. Compare and contrast the operations value chains of these two businesses as they pertain to the management of bicycles.

In the low-cost student rental business, used bicycles are acquired as cheaply as possible (e.g., garage sales, campus and community police unclaimed bicycle auctions, classified ads, etc.). Minimal care and maintenance are provided, such as tyre repair, lubrication and brake and gear adjustment. If anything significant is damaged on the bicycle it is disposed of as landfill.

In the high-service rental business, new bicycles are purchased from known, quality bicycle manufacturers. An array of types, models and sizes will be acquired to satisfy a range of bicycle preferences. Maintenance will be meticulous so that every bicycle is well-tuned prior to each rental. When a bicycle gets to the end of its service life, possibly after a year or two of use, it is sold because it will still have a good market value.

b. Describe a business process for maintaining bicycles for both businesses.

In the low-cost student rental business, maintenance is performed only in response to a customer complaint. Otherwise, the bicycle is assumed to be okay. In the high-service rental business, a maintenance checklist is performed after each bicycle is returned from a rental before it is released to be rented again.

c. Describe a business process for acquiring bicycles for both businesses.

In the low-cost student rental business, cheap bicycle sources are utilised (e.g., garage sales, campus and community police unclaimed bicycle auctions, classified ads, etc.). In the high-service rental business, the latest models are purchased from the most well-known bicycle manufacturers.

d. Describe a business process for disposing of bicycles for both businesses.

In the low-cost student rental business, bicycles are used until they break down completely. Disposal involves disposing of them as landfill. In the high-service rental business, the bicycles will have a lot of market value and so disposal will involve reselling them, perhaps using eBay to get the best possible price for the bicycle.

e. What roles do you see for information systems in your answers to the earlier questions? The information systems can be those you develop within your company or they can be those developed by others.

The information system for the low-cost student rental business will be quite simple, perhaps an index card for each bicycle in inventory. The information system for the high-service rental business could be more sophisticated, with complete information on each bicycle's acquisition and maintenance records.

5. Samantha Green owns and operates Twigs Tree Trimming Service. Samantha graduated from the forestry program of a nearby university and

[Return to start of document](#)

*worked for a large landscape design firm, performing tree trimming and removal. After several years gaining experience, she bought her own truck, stump grinder and other equipment and opened her own business in Brisbane.*

*Although many of her jobs are one-time operations to remove a tree or stump, others are recurring, such as trimming a tree or groups of trees every year or every other year. When business is slow, she calls former clients to remind them of her services and of the need to trim their trees on a regular basis.*

*Samantha has never heard of Michael Porter or any of his theories. She operates her business 'by the seat of her pants'.*

*a. Explain how an analysis of the five competitive forces could help Samantha.*

By looking at the five competitive forces, Samantha can better understand how to achieve a profitable performance in her industry. In this situation, the bargaining power of customers may be relatively strong with the ability to select another tree service based on price and responsiveness. Customers will not perceive differences in quality when removing a tree, other than judging response time and the thoroughness of cleanup. With tree trimming for tree maintenance, quality work will be harder for customers to appreciate. Samantha will have to sell her training and experience. The threat of substitution is a fairly weak force with few alternatives available to customers who have a dead or damaged tree that needs removing. There is, however, the option of doing nothing in terms of tree maintenance. Samantha needs to emphasise the benefits of performing regular tree trimming for long-term tree health. The bargaining power of suppliers of equipment is a weak force with many options available for machinery and equipment. The threat of new entrants is somewhat strong because anyone with a ladder, saw and no fear of heights could sell himself or herself as a tree trimmer. Samantha will have to sell her training and expertise. Finally, rivalry among existing firms is probably strong. Samantha will have to work to make her company's name well known, sell her professional knowledge and training, be responsive and keep her prices competitive.

*b. Do you think Samantha has a competitive strategy? What competitive strategy would seem to make sense for her?*

Samantha probably has not thought about a competitive strategy. Many small business owners have not stepped back from the hectic pace of just keeping the business going to consider this issue. For Samantha, given her forestry education, a differentiation strategy with a focus on the tree health and maintenance industry segment may make sense. Her education will clearly distinguish her from many others in the field and she should be able to capitalise on that with residential and commercial properties requiring regular tree maintenance.

*c. How would knowledge of her competitive strategy help her sales and marketing efforts?*

Samantha should not try to be all things to all parts of her market. She should focus her efforts on making her company's name well known, selling her professional knowledge and training, being responsive to customer calls and keeping her prices competitive but not necessarily rock-bottom.

[Return to start of document](#)

*d. Describe, in general terms, the kind of information system that Samantha needs to support sales and marketing efforts.*

Samantha needs several things from an information system. She needs to be responsive to customer calls, so she needs a system to help her track and respond to calls in a timely way. This system should also build her database of customer prospects so that she can target her follow-up and ongoing tree maintenance sales efforts. The system should allow her to keep good notes about each customer's trees so she can provide helpful information and services as needed to combat diseases that might threaten tree health.

### ***Collaboration exercise 3***

*1. Explain the relationship between value and cost according to the Porter model. When does it make sense to add cost to a business process?*

According to Porter's value chain model, a business process must generate more value than cost. Adding cost to a process makes sense if the additional cost produces value that exceeds that cost.

*2. Suppose you are told that the business process in Figure 3.8 has a negative margin. Explain what that means. Suppose the margin of some business process is negative \$1 million. If costs are reduced by \$1.2 million, will the margin necessarily be positive? Explain why, or why not.*

A negative margin means that the value produced by the process is less than the cost associated with the process. Reducing costs may improve the margin, but possibly not by the full amount of the cost reduction because the value produced by the process may also be reduced.

*3. Consider the alternative of replacing the rental personnel from the business process in Figure 3.8.*

*a. Describe changes that will need to be made to the process documented in Figure 3.8. One way to answer is to scan a copy of this diagram and annotate the changes on that copy. Or, if the annotations are too extensive, make another version of the diagram entirely.*

This figure replaces much of the rental personnel's interactions with the customer with a website. The customer basically uses a self-service process to reserve a bike and return the bike. The only role for people is to do the physical maintenance of the bicycles.

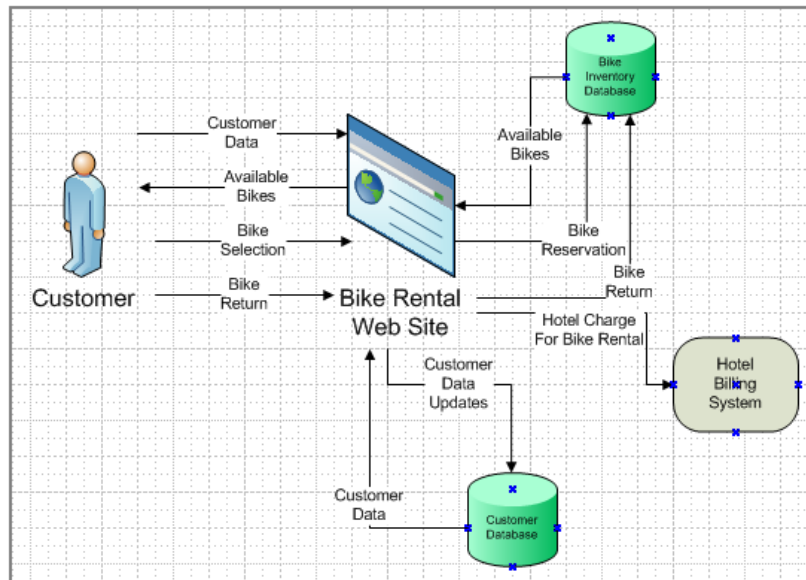

*b. Would eliminating the rental personnel change the competitive strategy of this company? Is it possible to be a high-value company with no rental personnel? Explain why, or why not.*

In a sense, the competitive strategy has changed. Differentiation is still important, but rather than focusing on a 'high-touch' mode of service, this change substitutes a high-tech mode of service. It is possible to be a high-value company with no rental personnel *if* the website is designed correctly and *if* the customers are accepting of the substitution of technology for people.

*c. Would eliminating the rental personnel necessarily reduce costs? What costs would increase as a result of this change?*

The costs of developing and maintaining the website, databases and servers would have to be factored into the value chain. People would have to do these tasks. Their costs might be higher than the costs of the bike rental personnel; certainly, these are more costly skills.

*4. Consider the alternative of increasing the value delivered by existing rental personnel. The text suggests possibly renting more kinds of equipment or selling items of use to guests who are renting bicycles, but consider other options as well.*

*a. Describe five ways that you think the existing personnel could increase the value of this business process.*

Student answers will vary. Some possible ideas include selling related items, such as bike clothing and shoes; renting helmets and saddlebags for the bike; selling snacks, bottled water and boxed meals fit for trail rides; and providing guides for trail rides of varying lengths and levels of difficulty.

*b. For the five alternatives you developed in part a, name and describe criteria for selecting among them.*

[Return to start of document](#)

Student answers will vary. Selection criteria should focus on identifying the options that will be most in demand by customers; that will add more value than cost; and that will be consistent with the overall business strategy.

*c. Using your criteria in part b, evaluate the alternative you identified in part a and select the best one. Explain your selection.*

Student answers will vary. Look for the student's choice to be justified by a careful analysis and application of their selection criteria in part b.

*d. Redraw Figure 3.8 for the alternative you selected in part c.*

Student answers will vary.

### **Case study 3—competitive advantage at National Australia Bank**

*1. Analyse the five competitive forces for NAB's market.*

The bargaining power of customers is relatively strong with the ability to select products from other banks based on price and performance. The bargaining power of suppliers is also quite strong, with fluctuations in the global economy directly affecting NAB's ability to buy and sell currency, shares, etc. at profitable rates. However, these 'suppliers' are not generally bargaining directly with NAB—global financial markets are influenced by a wide range of political and economic factors, but NAB needs to be aware of what is happening with its suppliers. The threat of new entrants is weak because there are significant barriers to entry in this industry: significant upfront investment in real estate; strong existing competitors who are well established; existing supply chains already well established; and government regulation hurdles for new entrants to overcome. The threat of substitution is a fairly strong force as competitors sell near-identical products that deliver the same value to the customer. Finally, rivalry among existing firms is strong—although relatively small in number, there are well-established competitors.

*2. What appears to be NAB's competitive strategy? Explain your answer.*

NAB promotes itself as Australia's largest business bank, so a key element to its competitive strategy is a Focus/Differentiation strategy as described in Table 3.2. That is, it aims to provide a better product/service within an industry segment (business banking). Students might also answer Industry-wide/Differentiation, as NAB no doubt also aims to deliver the best possible product/service to its personal banking customers, therefore hoping to deliver a better product/service across the industry.

*3. Explain the nature of the five primary value chain activities for NAB.*

Inbound logistics involves obtaining funds and credit from Australian and global financial markets through investment returns, buying and selling financial instruments, etc. Operations involves selling products to customers such as mortgages, car loans, savings accounts (personal customers) and lines of credit and merchant services like EFTPOS and e-commerce support (business customers). Outbound logistics involves delivery of the product to

[Return to start of document](#)

the customers, traditionally through its network of branches, but increasingly online. Service and support involves responding to customer information about their products, and in some cases, recommending higher value or additional products to existing customers (upselling). Sales and marketing involves advertising their financial products to their customer segments and convincing the customer to select a NAB product rather than those of their competitors.

*4. Review the principles of competitive advantage in Table 3.5. What information systems can NAB create to enhance its product or differentiate itself from existing and emerging competition?*

NAB can and does enhance its delivery of banking services through information systems as described in the case study. Recent improvements in their mobile banking app have met with customer satisfaction, as has moving to a 'real-time' model for internet transactions. If NAB's competitors are weaker in these areas, for example, it allows NAB to differentiate itself. In the banking sector, many of the available products are, by necessity and by government regulation, similar (e.g., mortgages, savings accounts). It is often difficult to enhance the underlying product, so banks tend to focus on differentiation through the delivery of that product to the customer (e.g., mobile banking) and through customer service provided. Therefore these are the two areas where NAB can focus on developing information systems to support competitive advantage: product delivery and customer service.

*5. What information systems can NAB develop to create barriers to entry to the competition?*

As discussed earlier, the banking sector already has very high barriers to entry, because of high establishment costs, government regulation, and the need to gain customer trust. New entrants to the market over the last 20 years have tended to be either low-cost online banking providers, or overseas banks which have created products aimed at the Australian market. In response to the rise of low-cost, online-only banking services, established bricks-and-mortar banks like NAB created (or acquired) their own low-cost, online-only banking services like NAB's UBank. Information systems are critical to companies being able to efficiently offer products and services through multiple channels or brands like this. Another way to think of it is that the same parent company uses different brands to adopt more than one of Porter's competitive strategies (one brand to compete on better product/service and a different brand to compete on lower cost). By covering more of the market, they are raising barriers to entry even higher by occupying as much of the available market space as possible to lock others out.

*6. What information systems can NAB develop to lock in customers?*

There are at least two ways that banks can try to lock in customers—one is by providing a superior customer experience that cannot be matched by competitors, and the other is to create switching costs for the customer. Information systems can play a role in both of these strategies. Continually enhancing the information systems used to deliver the products, for example, through enhanced online and mobile banking services, and staying ahead of the competition is a way to lock customers in through providing superior customer experience without necessarily increasing staff costs (e.g., without

[Return to start of document](#)

having more staff in branches).

Banks can also use information systems to create switching costs; for example, NAB could develop and give each of its small business customers access to a free accounting software package. The catch being that NAB's business accounting software only interfaces with NAB's own online banking service, so if a business customer later wanted to switch their accounts to another bank, they would also have to replace the accounting software. For business customers, providing a seamless integration between online banking, EFTPOS terminals, online accounts payables and receivables, and support for preparing business reports like Australia's Business Activity Statement (BAS) are ways to lock in business customers by offering them a superior customer experience and by creating switching costs.

#### *7. What information systems can NAB develop to establish alliances?*

Examples include:

- Mortgage brokers—providing an information system portal for mortgage brokers to get loan pre-approvals for their clients;
- Financial planners—providing financial planners with up-to-date data on NAB's investment products and historical performance trends;
- Tax accountants—providing an information system that either allows accountants to directly access tax-related data for their clients (with the client's permission), or providing services for clients to download data that they can provide to their accountant electronically;
- Superannuation companies—providing an information system that allows customers to access their superannuation balances through NAB's online banking portal.

NAB does indeed already have some of these information systems. Enhancing these systems in order to stay ahead of the competition and perhaps lock in customers is one possible competitive strategy that NAB could adopt.

[Return to start of document](#)