

Chapter 2

2.1

The resultant of each force system is 500N \uparrow .

Each resultant force has the same line of action as the the force in (a), except (f) and (h)

Therefore (b), (c), (d), (e) and (g) are equivalent to (a) \blacktriangleleft

2.2

$$R_x = \Sigma F_x : + \rightarrow R_x = 1335 \cos 70^\circ + 667 \cos 20^\circ = 1083 \text{ N}$$

$$R_y = \Sigma F_y : + \uparrow R_y = 1335 \sin 70^\circ + 667 \sin 20^\circ = 1483 \text{ N}$$

$$R = \sqrt{R_x^2 + R_y^2} = \sqrt{1083^2 + 1483^2} = 1863 \text{ N}$$

$$\theta = \tan^{-1} \left(\frac{1483}{1083} \right) = 53.9^\circ$$

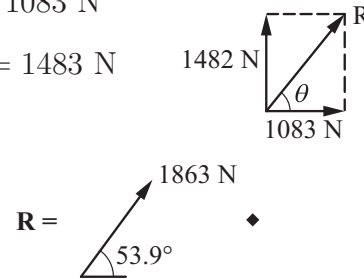

2.3

$$R_x = \Sigma F_x = -T_1 \cos 60^\circ + T_3 \cos 40^\circ$$

$$= -489 \cos 60^\circ + 667 \cos 40^\circ = 266.5 \text{ N}$$

$$R_y = \Sigma F_y = T_1 \sin 60^\circ + T_2 + T_3 \sin 40^\circ$$

$$= 489 \sin 60^\circ + 178 + 667 \sin 40^\circ = 1030 \text{ N}$$

$$R = \sqrt{266.5^2 + 1030^2} = 1064 \text{ N} \quad \blacktriangleleft$$

$$\theta = \tan^{-1} \frac{1030}{266.5} = 75.5^\circ \quad \blacktriangleleft$$

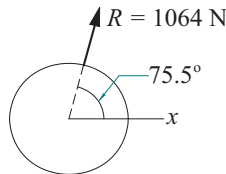

2.4

$$R_x = \Sigma F_x \quad + \rightarrow \quad R_x = 25 \cos 45^\circ + 40 \cos 60^\circ - 30$$

$$R_x = 7.68 \text{ kN}$$

$$R_y = \Sigma F_y \quad + \uparrow \quad R_y = 25 \sin 45^\circ - 40 \sin 60^\circ$$

$$R_y = -16.96 \text{ kN}$$

$$\mathbf{R} = 7.68\mathbf{i} - 16.96\mathbf{k} \text{ kN} \quad \blacktriangleleft$$

2.5

$$\mathbf{F}_1 = F_1 \boldsymbol{\lambda}_{AB} = 80 \frac{-120\mathbf{j} + 80\mathbf{k}}{\sqrt{(-120)^2 + 80^2}} = -66.56\mathbf{j} + 44.38\mathbf{k} \text{ N}$$

$$\begin{aligned} \mathbf{F}_2 &= F_2 \boldsymbol{\lambda}_{AC} = 60 \frac{-100\mathbf{i} - 120\mathbf{j} + 80\mathbf{k}}{\sqrt{(-100)^2 + (-120)^2 + 80^2}} \\ &= -34.19\mathbf{i} - 41.03\mathbf{j} + 27.35\mathbf{k} \text{ N} \end{aligned}$$

$$\mathbf{F}_3 = F_3 \boldsymbol{\lambda}_{AD} = 50 \frac{-100\mathbf{i} + 80\mathbf{k}}{\sqrt{(-100)^2 + 80^2}} = -39.04\mathbf{i} + 31.24\mathbf{k} \text{ N}$$

$$\begin{aligned} \mathbf{R} &= \Sigma \mathbf{F} = (-34.19 - 39.04)\mathbf{i} + (-66.56 - 41.03)\mathbf{j} \\ &\quad + (44.38 + 27.35 + 31.24)\mathbf{k} \\ &= -73.2\mathbf{i} - 107.6\mathbf{j} + 103.0\mathbf{k} \text{ N} \quad \blacktriangleleft \end{aligned}$$

2.6

(a) $\mathbf{P}_1 = 489\mathbf{j} \text{ N}$ $\mathbf{P}_2 = -890 \cos 25^\circ \mathbf{i} + 890 \sin 25^\circ \mathbf{j} = -807\mathbf{i} + 376\mathbf{j} \text{ N}$

$$\mathbf{P}_3 = -667 \cos 40^\circ \mathbf{i} + 667 \sin 40^\circ \mathbf{k} = -511\mathbf{i} + 429\mathbf{k} \text{ N}$$

$$\begin{aligned} \mathbf{R} &= \Sigma \mathbf{P} = (-807 - 511)\mathbf{i} + (489 + 376)\mathbf{j} + 429\mathbf{k} \text{ N} \\ &= -1318\mathbf{i} + 865\mathbf{j} + 429\mathbf{k} \text{ N} \end{aligned}$$

$$\therefore R = \sqrt{(-1318)^2 + 865^2 + 429^2} = 1634 \text{ N} \quad \blacklozenge$$

$$\frac{\overline{AB}_x}{|R_x|} = \frac{\overline{AB}_y}{|R_y|} = \frac{\overline{AB}_z}{|R_z|} \quad ; \quad \frac{0.67}{1318} = \frac{y}{865} = \frac{z}{429}$$

$$y = \frac{0.67(865)}{1318} = 0.4398 \text{ m}$$

$$z = \frac{0.67(429)}{1318} = 0.2181 \text{ m}$$

$$\therefore \mathbf{R} \text{ passes through the point } (0, 0.4398 \text{ m}, 0.2181 \text{ m}) \quad \blacklozenge$$

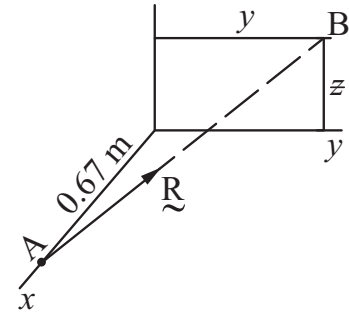

(b)

2.7

$$\begin{aligned} \mathbf{R} &= (-P_2 \cos 25^\circ - P_3 \cos 40^\circ)\mathbf{i} + (P_1 + P_2 \sin 25^\circ)\mathbf{j} + P_3 \sin 40^\circ \mathbf{k} \\ &= -3560\mathbf{i} + 3115\mathbf{j} + 2225\mathbf{k} \text{ lb} \end{aligned}$$

Equating like coefficients:

$$-P_2 \cos 25^\circ - P_3 \cos 40^\circ = -3560$$

$$P_1 + P_2 \sin 25^\circ = 3115$$

$$P_3 \sin 40^\circ = 2225$$

Solution is

$$P_1 = 2690 \text{ N} \quad \blacktriangleleft \quad P_2 = 1000 \text{ N} \quad \blacktriangleleft \quad P_3 = 3460 \text{ N} \quad \blacktriangleleft$$

2.8

$$\begin{aligned} \mathbf{T}_1 &= 90 \frac{-\mathbf{i} + 2\mathbf{j} + 6\mathbf{k}}{\sqrt{(-1)^2 + 2^2 + 6^2}} = -14.06\mathbf{i} + 28.11\mathbf{j} + 84.33\mathbf{k} \text{ kN} \\ \mathbf{T}_2 &= 60 \frac{-2\mathbf{i} - 3\mathbf{j} + 6\mathbf{k}}{\sqrt{(-2)^2 + (-3)^2 + 6^2}} = -17.14\mathbf{i} - 25.71\mathbf{j} + 51.43\mathbf{k} \text{ kN} \\ \mathbf{T}_3 &= 40 \frac{2\mathbf{i} - 3\mathbf{j} + 6\mathbf{k}}{\sqrt{2^2 + (-3)^2 + 6^2}} = 11.43\mathbf{i} - 17.14\mathbf{j} + 34.29\mathbf{k} \text{ kN} \\ \mathbf{R} &= \mathbf{T}_1 + \mathbf{T}_2 + \mathbf{T}_3 = (-14.06 - 17.14 + 11.43)\mathbf{i} \\ &\quad + (28.11 - 25.71 - 17.14)\mathbf{j} + (84.33 + 51.43 + 34.29)\mathbf{k} \\ &= -19.77\mathbf{i} - 14.74\mathbf{j} + 170.05\mathbf{k} \text{ kN} \quad \blacktriangleleft \end{aligned}$$

2.9

$$\begin{aligned} \mathbf{T}_1 &= T_1 \frac{-\mathbf{i} + 2\mathbf{j} + 6\mathbf{k}}{\sqrt{(-1)^2 + 2^2 + 6^2}} = T_1(-0.15617\mathbf{i} + 0.3123\mathbf{j} + 0.9370\mathbf{k}) \\ \mathbf{T}_2 &= T_2 \frac{-2\mathbf{i} - 3\mathbf{j} + 6\mathbf{k}}{\sqrt{(-2)^2 + (-3)^2 + 6^2}} = T_2(-0.2857\mathbf{i} - 0.4286\mathbf{j} + 0.8571\mathbf{k}) \\ \mathbf{T}_3 &= T_3 \frac{2\mathbf{i} - 3\mathbf{j} + 6\mathbf{k}}{\sqrt{2^2 + (-3)^2 + 6^2}} = T_3(0.2857\mathbf{i} - 0.4286\mathbf{j} + 0.8571\mathbf{k}) \\ \mathbf{T}_1 + \mathbf{T}_2 + \mathbf{T}_3 &= \mathbf{R} \end{aligned}$$

Equating like components, we get

$$\begin{aligned} -0.15617T_1 - 0.2857T_2 + 0.2857T_3 &= 0 \\ 0.3123T_1 - 0.4286T_2 - 0.4286T_3 &= 0 \\ 0.9370T_1 + 0.8571T_2 + 0.8571T_3 &= 210 \end{aligned}$$

Solution is

$$T_1 = 134.5 \text{ kN} \quad \blacktriangleleft \quad T_2 = 12.24 \text{ kN} \quad \blacktriangleleft \quad T_3 = 85.8 \text{ kN} \quad \blacktriangleleft$$

2.10

$$\begin{aligned} \mathbf{R}_x = \Sigma \mathbf{F}_x: \quad \pm \quad \frac{1}{\sqrt{5}} P_1 + \frac{3}{5} P_2 - 20 &= 40 \cos 30^\circ \quad (1) \\ \mathbf{R}_y = \Sigma \mathbf{F}_y: \quad +\uparrow \quad \frac{2}{\sqrt{5}} P_1 - \frac{4}{5} P_2 &= 40 \sin 30^\circ \quad (2) \end{aligned}$$

Solving (1) and (2) gives:

$$\begin{aligned} P_1 &= 62.3 \text{ kN} \quad \blacklozenge \\ P_2 &= 44.6 \text{ kN} \quad \blacklozenge \end{aligned}$$

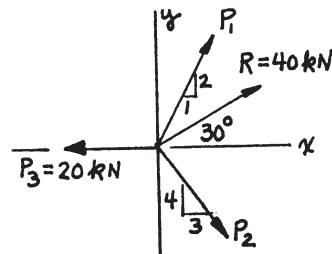

2.11

$$\begin{aligned}\mathbf{F}_1 &= -45 \cos 20^\circ \mathbf{i} - 45 \sin 20^\circ \mathbf{j} = -42.29\mathbf{i} - 15.39\mathbf{j} \text{ N} \\ \mathbf{F}_2 &= F_2(\sin 60^\circ \mathbf{i} + \cos 60^\circ \mathbf{j}) = F_2(0.8660\mathbf{i} + 0.5\mathbf{j}) \\ \mathbf{R} = \Sigma \mathbf{F} &= (-42.29 + 0.8660F_2)\mathbf{i} + (-15.39 + 0.5F_2)\mathbf{j} \\ \overrightarrow{AB} &= -102\mathbf{i} + 152\mathbf{j} \text{ mm}\end{aligned}$$

Because \mathbf{R} and \overrightarrow{AB} are parallel, their components are proportional:

$$\frac{-42.29 + 0.8660F_2}{-102} = \frac{-15.39 + 0.5F_2}{152}$$

$$F_2 = 60.3 \text{ N} \quad \blacktriangleleft$$

2.12

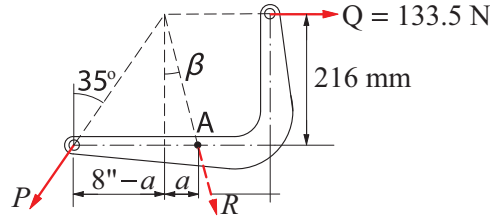

First find the direction of \mathbf{R} from geometry (the 3 forces must intersect at a common point).

$$8 - a = 8.5 \tan 35^\circ \quad \therefore a = 0.052 \text{ m}$$

$$\beta = \tan^{-1} \frac{a}{216} = \tan^{-1} \frac{0.052 \text{ m}}{216} = 13.547^\circ$$

$$\begin{aligned}R_x = \Sigma F_x \quad + \longrightarrow \quad R \sin 13.547^\circ &= -P \sin 35^\circ + 30 \\ R_y = \Sigma F_y \quad + \downarrow \quad R \cos 13.547^\circ &= P \cos 35^\circ\end{aligned}$$

Solution is

$$P = 17.6 \text{ kg} \quad \blacktriangleleft \quad R = 14.9 \text{ kg} \quad \blacktriangleleft$$

2.13

$$\mathbf{F}_{AB} = 67 \frac{305\mathbf{i} - 152\mathbf{j} + 229\mathbf{k}}{\sqrt{305^2 + (-152)^2 + 229^2}} = 49.772\mathbf{i} - 24.804\mathbf{j} + 37.37\mathbf{k} \text{ N}$$

$$\mathbf{F}_{AC} = -49.772\mathbf{i} - 24.804\mathbf{j} + 37.37\mathbf{k} \text{ N (by symmetry)}$$

$$\begin{aligned}\Sigma F_y = 0 : \quad 2(-24.804) + T &= 0 \\ T &= 49.6 \text{ N} \quad \blacktriangleleft\end{aligned}$$

2.14

$$\mathbf{P}_1 = 445 \frac{0.915\mathbf{i} + 1.22\mathbf{k}}{\sqrt{0.915^2 + 1.22^2}} = 267\mathbf{i} + 356\mathbf{k} \text{ N}$$

$$\mathbf{P}_2 = 534 \frac{0.915\mathbf{i} + 0.915\mathbf{j} + 1.22\mathbf{k}}{\sqrt{0.915^2 + 0.915^2 + 1.22^2}} = 274.8\mathbf{i} + 274.8\mathbf{j} + 366.4\mathbf{k} \text{ N}$$

$$\mathbf{P}_3 = 267\mathbf{j} \text{ N}$$

$$\mathbf{Q}_1 = Q_1\mathbf{i}$$

$$\mathbf{Q}_2 = Q_2 \frac{-0.915\mathbf{i} - 0.915\mathbf{j}}{\sqrt{0.915^2 + 0.915^2}} = Q_2(-0.7071\mathbf{i} - 0.7071\mathbf{j})$$

$$\mathbf{Q}_3 = Q_3 \frac{0.915\mathbf{j} + 1.22\mathbf{k}}{\sqrt{0.915^2 + 1.22^2}} = Q_3(0.6\mathbf{j} + 0.8\mathbf{k})$$

Equating similar components of $\Sigma\mathbf{Q} = \Sigma\mathbf{P}$:

$$Q_1 - 0.7071Q_2 = 267 + 274.8$$

$$-0.7071Q_2 + 0.6Q_3 = 274.8 + 267$$

$$0.8Q_3 = 356 + 366.4$$

Solution is

$$Q_1 = 541.8 \text{ N} \quad \blacktriangleleft \quad Q_2 = 0 \quad Q_3 = 903 \text{ N} \quad \blacktriangleleft$$

2.15

$$R_x = \Sigma F_x \quad + \rightarrow \quad 35.6 = 178 \sin 45^\circ - Q \sin 30^\circ \quad Q = 180.5 \text{ N}$$

$$R_y = \Sigma F_y \quad + \uparrow \quad 0 = 178 \cos 45^\circ - W + 180.5 \cos 30^\circ$$

$$\therefore W = 282.2 \text{ N} \quad \blacktriangleleft$$

2.16

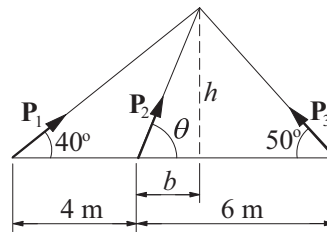

The forces must be concurrent. From geometry:

$$h = (4 + b) \tan 40^\circ = (6 - b) \tan 50^\circ \quad \therefore b = 1.8682 \text{ m} \quad \blacktriangleleft$$

$$\therefore h = (4 + 1.8682) \tan 40^\circ = 4.924 \text{ m}$$

$$\theta = \tan^{-1} \frac{h}{b} = \tan^{-1} \frac{4.924}{1.8682} = 69.22^\circ \quad \blacktriangleleft$$

$$\begin{aligned}\mathbf{R} = \Sigma \mathbf{F} &= (25 \cos 40^\circ + 60 \cos 69.22^\circ - 80 \cos 50^\circ)\mathbf{i} \\ &+ (25 \sin 40^\circ + 60 \sin 69.22^\circ + 80 \sin 50^\circ)\mathbf{j} \\ &= -10.99\mathbf{i} + 133.45\mathbf{j} \text{ kN} \quad \blacktriangleleft\end{aligned}$$

2.17

The three forces intersect at C.

$$h = 1.2 \tan 25^\circ = 0.5596 \text{ m}$$

For the 240-N force :

$$\begin{aligned}-240(\cos 25^\circ \mathbf{i} - \sin 25^\circ \mathbf{k}) &= \\ -217.5\mathbf{i} + 101.4\mathbf{k} \text{ N}\end{aligned}$$

For the 300-N force ($300 \lambda_{BC}$):

$$\begin{aligned}300 \left(\frac{-1.2\mathbf{i} - 1.2\mathbf{j} + 0.5596\mathbf{k}}{1.787} \right) &= \\ -201.5\mathbf{i} - 201.5\mathbf{j} + 93.95\mathbf{k} \text{ N}\end{aligned}$$

$\mathbf{R} = \Sigma \mathbf{F}$

$$= (-217.5 - 201.5)\mathbf{i} - 201.5\mathbf{j} + (101.4 + 93.95)\mathbf{k} = -419.0\mathbf{i} - 201.5\mathbf{j} + 195.4\mathbf{k} \text{ N} \quad \blacklozenge$$

$$\text{Since } \mathbf{R} \text{ acts along } \overline{AC}: \frac{|R_y|}{y_A} = \frac{|R_x|}{1.2} \quad \therefore y_A = \frac{|R_y|}{|R_x|} (1.2) = \frac{201.5}{419.0} (1.2) = 0.577 \text{ m} \quad \blacklozenge$$

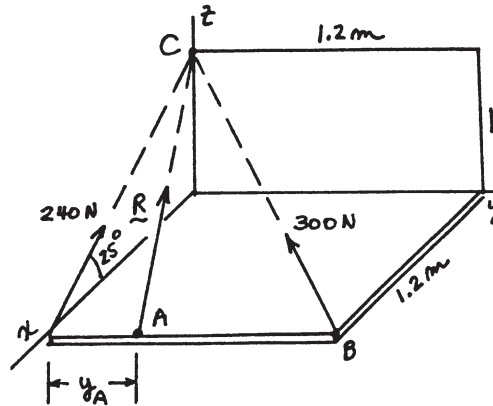

2.18

$$\mathbf{T}_1 = 800 \frac{0.915\mathbf{i} - 0.61\mathbf{j} - 1.83\mathbf{k}}{\sqrt{0.915^2 + (-0.61)^2 + (-1.83)^2}} = 343\mathbf{i} - 229\mathbf{j} - 686\mathbf{k} \text{ N}$$

$$\mathbf{T}_2 = 1112 \frac{0.915\mathbf{j} - 1.83\mathbf{k}}{\sqrt{0.915^2 + (-1.83)^2}} = 386\mathbf{j} - 771\mathbf{k} \text{ N}$$

$$\mathbf{T}_3 = 1780 \frac{-1.22\mathbf{i} - 1.83\mathbf{k}}{\sqrt{(-1.22)^2 + (-1.83)^2}} = -988\mathbf{i} - 1480\mathbf{k} \text{ N}$$

$$\begin{aligned}\mathbf{R} = \Sigma \mathbf{T} &= (343 - 988)\mathbf{i} + (-229 + 386)\mathbf{j} \\ &+ (-686 - 771 - 1480)\mathbf{k} \\ &= -645\mathbf{i} + 157\mathbf{j} - 2937\mathbf{k} \text{ N} \quad \blacktriangleleft \text{ acting through point } A.\end{aligned}$$

2.19

$$\begin{aligned}\mathbf{T}_{AB} = T_{AB} \lambda_{AB} &= 534 \frac{0.915\mathbf{i} - 3.66\mathbf{j} + 3.05\mathbf{k}}{\sqrt{0.915^2 + (-3.66)^2 + 3.05^2}} \\ &= 100.7\mathbf{i} - 402.9\mathbf{j} + 402.9\mathbf{k} \text{ N}\end{aligned}$$

$$\begin{aligned}\mathbf{T}_{AC} = T_{AC} \lambda_{AC} &= 712 \frac{-2.44\mathbf{i} - 3.66\mathbf{j} + 0.915\mathbf{k}}{\sqrt{(-2.44)^2 + (-3.66)^2 + 0.915^2}} \\ &= -386.7\mathbf{i} - 580.0\mathbf{j} + 145.0\mathbf{k} \text{ lb}\end{aligned}$$

$$\begin{aligned}
 \mathbf{R} &= \mathbf{T}_{AB} + \mathbf{T}_{AC} - W\mathbf{k} \\
 &= (100.7 - 386.7)\mathbf{i} + (-402.9 - 580.0)\mathbf{j} + (402.9 + 145.0 - 480)\mathbf{k} \\
 &= -286.0\mathbf{i} - 982.9\mathbf{j} + 67.9\mathbf{k} \text{ N} \quad \blacktriangleleft
 \end{aligned}$$

2.20

Choose the line of action of the middle force as the x -axis.

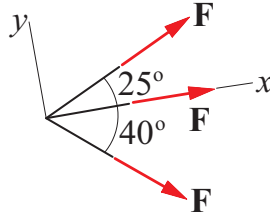

$$R_x = \Sigma F_x = F(\cos 25^\circ + 1 + \cos 40^\circ) = 2.672F$$

$$R_y = \Sigma F_y = F(\sin 25^\circ - \sin 40^\circ) = -0.2202F$$

$$R = F\sqrt{2.672^2 + (-0.2202)^2} = 2.681F$$

$$1780 = 2.681F \quad \therefore F = 664 \text{ N} \quad \blacktriangleleft$$

*2.21

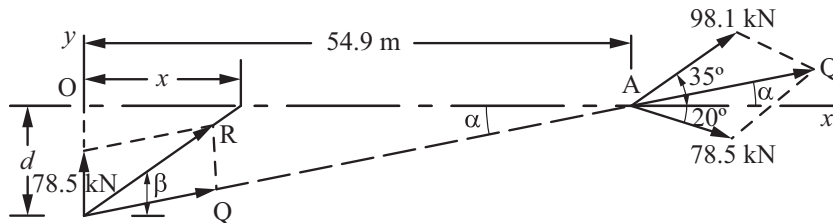

Let \mathbf{Q} be the resultant of the two forces at A.

$$+\rightarrow Q_x = \Sigma F_x = 98.1 \cos 35^\circ + 78.5 \cos 20^\circ = 154.1 \text{ kN}$$

$$+\uparrow Q_y = \Sigma F_y = 98.1 \sin 35^\circ - 78.5 \sin 20^\circ = 29.4 \text{ kN}$$

$$\therefore \tan \alpha = Q_y/Q_x = 29.4/154.1 = 0.1909$$

Let \mathbf{R} be the resultant of \mathbf{Q} and the 78.5-kN vertical force.

$$+\rightarrow R_x = \Sigma F_x = Q_x = 154.1 \text{ kN}$$

$$+\uparrow R_y = \Sigma F_y = 78.5 + Q_y = 78.5 + 29.4 = 107.9 \text{ kN}$$

$$\therefore \mathbf{R} = 154.1\mathbf{i} + 107.9\mathbf{j} \text{ kN} \quad \blacklozenge$$

(Note that $\tan \beta = R_y/R_x = 107.9/154.1 = 0.7002$)

To find x : $d = 54.9 \tan \alpha = 54.9(0.1909) = 10.48 \text{ m}$

$$x = d/\tan \beta = 10.48/0.7002 = 14.97 \text{ m} \quad \blacklozenge$$

2.22

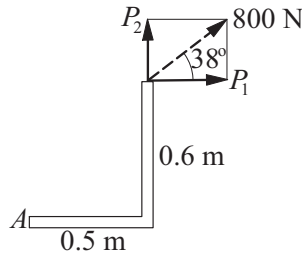

$$\begin{aligned}
 + \circlearrowleft M_A &= -0.6P_1 + 0.5P_2 \\
 &= -0.6(800 \cos 38^\circ) + 0.5(800 \sin 38^\circ) = -132.0 \text{ N} \cdot \text{m} \\
 \therefore M_A &= 132.0 \text{ N} \cdot \text{m} \circlearrowleft \blacktriangleleft
 \end{aligned}$$

2.23

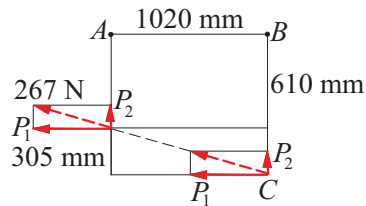

$$P_1 = 267 \frac{1020}{\sqrt{1020^2 + 305^2}} = 255.7 \text{ N}$$

With the force in the original position:

$$M_A = 0.610P_1 = 0.610(255.7) = 156 \text{ N} \cdot \text{m} \circlearrowleft \blacktriangleleft$$

With the force moved to point C:

$$M_B = 36P_1 = 0.915(255.7) = 234 \text{ N} \cdot \text{m} \circlearrowleft \blacktriangleleft$$

2.24

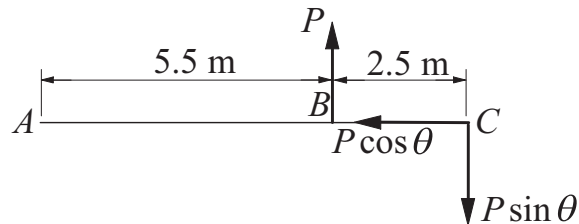

Resolve the force at C into components as shown. Adding the moments of the forces about A yields

$$\begin{aligned}
 + \circlearrowleft M_A &= 5.5P - 8P \sin \theta = 0 \\
 \sin \theta &= \frac{5.5}{8} = 0.6875 \quad \theta = 43.4^\circ \blacktriangleleft
 \end{aligned}$$

2.25

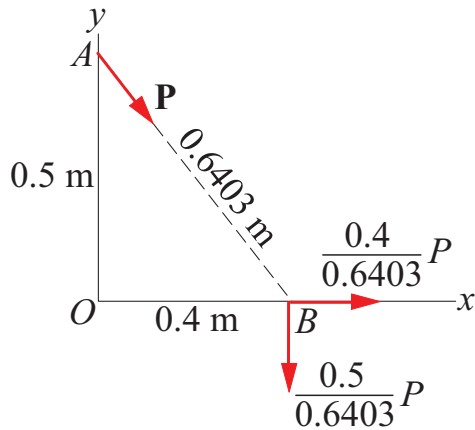

Since $M_A = M_B = 0$, the force \mathbf{P} passes through A and B , as shown.

$$+\circlearrowleft M_O = \frac{0.5}{0.6403} P(0.4) = 350 \text{ kN} \cdot \text{m} \quad P = 1120.5 \text{ N}$$

$$\mathbf{P} = \frac{0.4}{0.6403} 1120.5 \mathbf{i} - \frac{0.5}{0.6403} 1120.5 \mathbf{j} = 700 \mathbf{i} - 875 \mathbf{j} \text{ N} \quad \blacktriangleleft$$

2.26

Since $M_B = 0$, \mathbf{P} passes through B .

$$\begin{aligned} \curvearrowright M_O &= 0.4 P_y = 80 \text{ N} \cdot \text{m} \\ P_y &= 200 \text{ N} \\ \curvearrowright M_A &= 0.4(200) + 0.5 P_x = -200 \text{ N} \cdot \text{m} \\ P_x &= -280/0.5 = -560 \text{ N} \\ \therefore \mathbf{P} &= -560 \mathbf{i} + 200 \mathbf{j} \text{ N} \quad \blacklozenge \end{aligned}$$

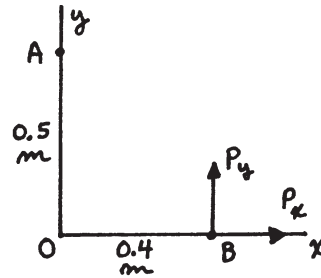

2.27

$$\mathbf{F} = 40 \mathbf{i} + 80 \mathbf{j} \text{ N}$$

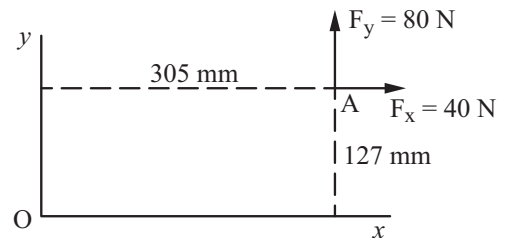

(a)

$$\begin{aligned} \mathbf{M}_O &= \mathbf{r}_{OA} \times \mathbf{F} = \begin{vmatrix} \mathbf{i} & \mathbf{j} & \mathbf{k} \\ 0.305 & 0.127 & 0 \\ 40 & 80 & 0 \end{vmatrix} \\ &= \mathbf{k} [80(0.305) - 0.127(40)] = 19.32 \mathbf{k} \text{ N} \cdot \text{m} \quad \blacklozenge \end{aligned}$$

(b) $\curvearrowright M_O = 80(0.305) - 0.127(40) = 19.32 \text{ N} \cdot \text{m} \quad \therefore M_O = 19.32 \text{ N} \cdot \text{m CCW} \blacklozenge$

(c) Unit vector perpendicular to OA is

$$\begin{aligned}\vec{\lambda} &= -\frac{127}{330} \mathbf{i} + \frac{305}{330} \mathbf{j} \\ F_1 &= \mathbf{F} \cdot \vec{\lambda} \\ &= (40\mathbf{i} + 80\mathbf{j}) \cdot \left(-\frac{127}{330} \mathbf{i} + \frac{305}{330} \mathbf{j}\right) \\ &= \frac{-5080 + 24,400}{330} = 58.55 \text{ N} \cdot \text{m}\end{aligned}$$

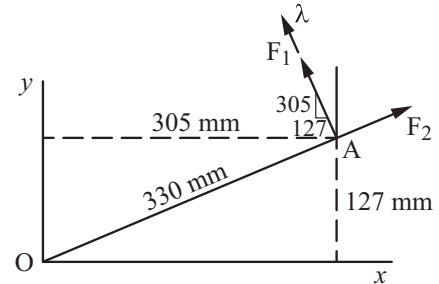

$\curvearrowright M_O = 0.330F_1 = 0.330(58.55) = 19.32 \text{ N} \cdot \text{m} \quad \therefore M_O = 19.32 \text{ N} \cdot \text{m CCW} \blacklozenge$

2.28

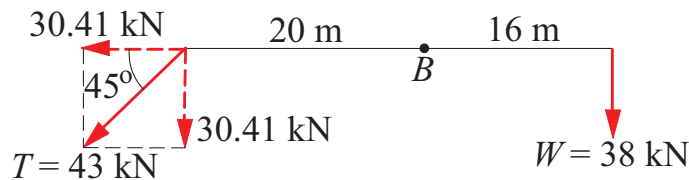

(a) Moment of \mathbf{T} :

$$+ \curvearrowright M_B = 30.41(20) = 608 \text{ kN} \cdot \text{m CCW} \blacktriangleleft$$

(b) Moment of \mathbf{W} :

$$+ \curvearrowright M_B = 38(16) = 608 \text{ kN} \cdot \text{m CW} \blacktriangleleft$$

(c) Combined moment:

$$+ \curvearrowright M_B = 608 - 608 = 0 \blacktriangleleft$$

2.29

The moment of \mathbf{F} about O is maximum when $\theta = 90^\circ \blacklozenge$

$$M_O = F(0.381) = 67.8 \text{ N} \cdot \text{m} \quad \therefore F = \frac{67.8}{0.381} = 178 \text{ N} \blacklozenge$$

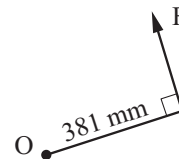

2.30

(a)

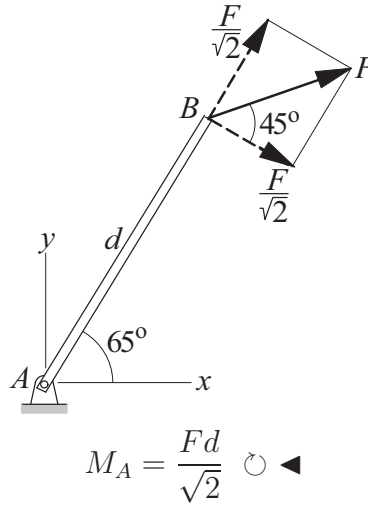

(b)

$$\mathbf{F} = F \cos 20^\circ \mathbf{i} + F \sin 20^\circ \mathbf{j}$$

$$\mathbf{r} = \overrightarrow{AB} = d \cos 65^\circ \mathbf{i} + d \sin 65^\circ \mathbf{j}$$

$$\begin{aligned} \mathbf{M}_A = \mathbf{r} \times \mathbf{F} &= \begin{vmatrix} \mathbf{i} & \mathbf{j} & \mathbf{k} \\ \cos 65^\circ & \sin 65^\circ & 0 \\ \cos 20^\circ & \sin 20^\circ & 0 \end{vmatrix} Fd \\ &= (\sin 20^\circ \cos 65^\circ - \cos 20^\circ \sin 65^\circ) Fd \mathbf{k} = -0.707 Fd \mathbf{k} \quad \blacktriangleleft \end{aligned}$$

2.31

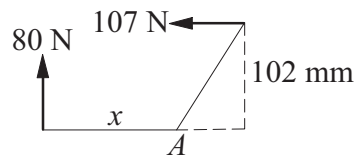

Because the resultant passes through point A, we have

$$\Sigma M_A = 0 \quad + \circlearrowleft 107(102) - 80x = 0 \quad x = 136 \text{ mm} \quad \blacktriangleleft$$

2.32

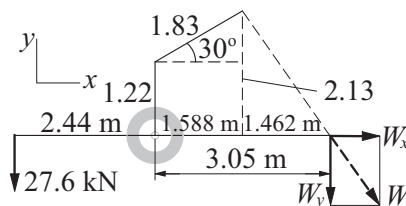

$$W_y = W \frac{2.13}{\sqrt{2.13^2 + 1.462^2}} = 0.8245W$$

Largest W occurs when the moment about the rear axle is zero.

$$+ \circlearrowleft M_{\text{axle}} = 27.6 \text{ kN}(2.44) - (0.8245W)(3.05) = 0$$

$$\therefore W = 26.8 \text{ kN} \quad \blacktriangleleft$$

2.33

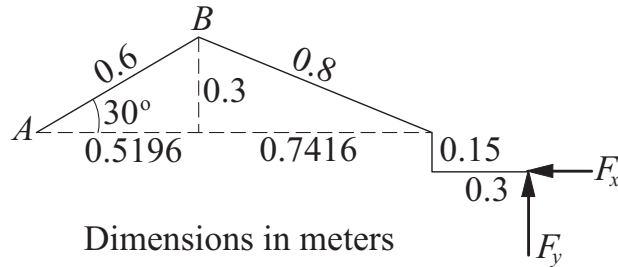

$$+ \circlearrowleft M_A = -F_x(0.15) + F_y(0.5196 + 0.7416 + 0.3)$$

$$310 = -0.15F_x + 1.5612F_y \quad (\text{a})$$

$$+ \circlearrowleft M_B = -F_x(0.3 + 0.15) + F_y(0.7416 + 0.3)$$

$$120 = -0.45F_x + 1.0416F_y \quad (\text{b})$$

$$310 = -0.15F_x + 1.5612F_y$$

$$120 = -0.45F_x + 1.0416F_y$$

Solution of Eqs. (a) and (b) is $F_x = 248.1 \text{ N}$ and $F_y = 222.4 \text{ N}$

$$\therefore F = \sqrt{248.1^2 + 222.4^2} = 333 \text{ N} \quad \blacktriangleleft$$

$$\theta = \tan^{-1} \frac{F_x}{F_y} = \tan^{-1} \frac{248.1}{222.4} = 48.1^\circ \quad \blacktriangleleft$$

2.34

$$\mathbf{P} = P \frac{-70\mathbf{i} - 100\mathbf{k}}{\sqrt{(-70)^2 + (-100)^2}} = (-0.5735\mathbf{i} - 0.8192\mathbf{k})P$$

$$\mathbf{r} = \overrightarrow{AB} = -0.07\mathbf{i} + 0.09\mathbf{j} \text{ m}$$

$$\mathbf{M}_A = \mathbf{r} \times \mathbf{P} = \begin{vmatrix} \mathbf{i} & \mathbf{j} & \mathbf{k} \\ -0.07 & 0.09 & 0 \\ -0.5735 & 0 & -0.8192 \end{vmatrix} P$$

$$= (-73.73\mathbf{i} - 57.34\mathbf{j} + 51.62\mathbf{k}) \times 10^{-3} P$$

$$M_A = \sqrt{(-73.73)^2 + (-57.34)^2 + 51.62^2} (10^{-3} P)$$

$$= 106.72 \times 10^{-3} P$$

Using $M_A = 15 \text{ N} \cdot \text{m}$, we get

$$15 = 106.72 \times 10^{-3} P \quad P = 140.6 \text{ N} \quad \blacktriangleleft$$

2.35

$$\begin{aligned} \mathbf{P} &= 160\lambda_{AB} = 160 \frac{-0.5\mathbf{i} - 0.6\mathbf{j} + 0.36\mathbf{k}}{\sqrt{(-0.5)^2 + (-0.6)^2 + 0.36^2}} \\ &= -93.02\mathbf{i} - 111.63\mathbf{j} + 66.98\mathbf{k} \text{ N} \end{aligned}$$

(a)

$$\mathbf{M}_O = \mathbf{r}_{OB} \times \mathbf{P} = \begin{vmatrix} \mathbf{i} & \mathbf{j} & \mathbf{k} \\ 0 & 0 & 0.36 \\ -93.02 & -111.63 & 66.98 \end{vmatrix} = 40.2\mathbf{i} - 33.5\mathbf{j} \text{ N} \cdot \text{m} \quad \blacktriangleleft$$

(b)

$$\mathbf{M}_C = \mathbf{r}_{CB} \times \mathbf{P} = \begin{vmatrix} \mathbf{i} & \mathbf{j} & \mathbf{k} \\ 0 & -0.6 & 0 \\ -93.02 & -111.63 & 66.98 \end{vmatrix} = -40.2\mathbf{i} - 55.8\mathbf{k} \text{ N} \cdot \text{m} \quad \blacktriangleleft$$

2.36

$$\mathbf{Q} = 250 \vec{\lambda}_{BD} = 250 \left(\frac{-0.500\mathbf{i} + 0.360\mathbf{k}}{0.6161} \right) = -202.9\mathbf{i} + 146.1\mathbf{k} \text{ N}$$

(a) $\mathbf{M}_O = \mathbf{r}_{OB} \times \mathbf{Q}$ $\mathbf{r}_{OB} = 0.360\mathbf{k} \text{ m}$ (\mathbf{r}_{OD} is also convenient)

$$\therefore \mathbf{M}_O = \begin{vmatrix} \mathbf{i} & \mathbf{j} & \mathbf{k} \\ 0 & 0 & 0.360 \\ -202.9 & 0 & 146.1 \end{vmatrix} = -73.0\mathbf{j} \text{ N} \cdot \text{m} \quad \blacklozenge$$

(b) $\mathbf{M}_C = \mathbf{r}_{CB} \times \mathbf{Q}$ $\mathbf{r}_{CB} = -0.600\mathbf{j} \text{ m}$ (\mathbf{r}_{CD} is also convenient)

$$\therefore \mathbf{M}_C = \begin{vmatrix} \mathbf{i} & \mathbf{j} & \mathbf{k} \\ 0 & -0.600 & 0 \\ -202.9 & 0 & 146.1 \end{vmatrix} = -87.7\mathbf{i} - 121.7\mathbf{k} \text{ N} \cdot \text{m} \quad \blacklozenge$$

2.37

$$\mathbf{r}_{OC} = 2\mathbf{i} + 4\mathbf{j} - 3\mathbf{k} \text{ m} \quad \mathbf{P} = P(-\cos 25^\circ \mathbf{i} + \sin 25^\circ \mathbf{k})$$

$$\mathbf{M}_O = P \begin{vmatrix} \mathbf{i} & \mathbf{j} & \mathbf{k} \\ 2 & 4 & -3 \\ -\cos 25^\circ & 0 & \sin 25^\circ \end{vmatrix} = P(1.6905\mathbf{i} + 1.8737\mathbf{j} + 3.6252\mathbf{k})$$

$$M_0 = P\sqrt{1.6905^2 + 1.8737^2 + 3.6252^2} = 4.417P = 350 \text{ kN} \cdot \text{m}$$

$$P = 79.2 \text{ kN} \quad \blacktriangleleft$$

2.38

$$\mathbf{P} = 50(-\cos 25^\circ \mathbf{i} + \sin 25^\circ \mathbf{k}) = -45.32 \mathbf{i} + 21.13 \mathbf{k} \text{ kN}$$

$$\text{(a) } \mathbf{M}_A = \mathbf{r}_{AC} \times \mathbf{P} \quad \mathbf{r}_{AC} = 4\mathbf{j} - 3\mathbf{k} \text{ m}$$

$$\therefore \mathbf{M}_A = \begin{vmatrix} \mathbf{i} & \mathbf{j} & \mathbf{k} \\ 0 & 4 & -3 \\ -45.32 & 0 & 21.13 \end{vmatrix} = 84.52 \mathbf{i} + 135.96 \mathbf{j} + 181.28 \mathbf{k} \text{ kN}\cdot\text{m}$$

$$\text{(b) } \mathbf{M}_B = \mathbf{r}_{BC} \times \mathbf{P} \quad \mathbf{r}_{BC} = 4\mathbf{j} \text{ m}$$

$$\therefore \mathbf{M}_B = \begin{vmatrix} \mathbf{i} & \mathbf{j} & \mathbf{k} \\ 0 & 4 & 0 \\ -45.32 & 0 & 21.13 \end{vmatrix} = 84.52 \mathbf{i} + 181.28 \mathbf{k} \text{ kN}\cdot\text{m}$$

2.39

$$\mathbf{P} = P\lambda_{BA} = 20 \frac{-2\mathbf{j} + 4\mathbf{k}}{\sqrt{(-2)^2 + 4^2}} = -8.944\mathbf{j} + 17.889\mathbf{k} \text{ kN}$$

$$\mathbf{Q} = Q\lambda_{AC} = 20 \frac{-2\mathbf{i} + 2\mathbf{j} - \mathbf{k}}{\sqrt{(-2)^2 + 2^2 + (-1)^2}} = -13.333\mathbf{i} + 13.333\mathbf{j} - 6.667\mathbf{k} \text{ kN}$$

$$\mathbf{r} = \overrightarrow{OA} = 2\mathbf{i} + 4\mathbf{k} \text{ m}$$

$$\begin{aligned} \mathbf{P} + \mathbf{Q} &= -13.333\mathbf{i} + (-8.944 + 13.333)\mathbf{j} + (17.889 - 6.667)\mathbf{k} \\ &= -13.333\mathbf{i} + 4.389\mathbf{j} + 11.222\mathbf{k} \text{ kN} \end{aligned}$$

$$\begin{aligned} \mathbf{M}_O = \mathbf{r} \times (\mathbf{P} + \mathbf{Q}) &= \begin{vmatrix} \mathbf{i} & \mathbf{j} & \mathbf{k} \\ 2 & 0 & 4 \\ -13.333 & 4.389 & 11.222 \end{vmatrix} \\ &= -17.56\mathbf{i} - 75.78\mathbf{j} + 8.78\mathbf{k} \text{ kN}\cdot\text{m} \quad \blacktriangleleft \end{aligned}$$

2.40

Noting that both \mathbf{P} and \mathbf{Q} pass through A , we have

$$\mathbf{M}_O = \mathbf{r}_{OA} \times (\mathbf{P} + \mathbf{Q}) \quad \mathbf{r}_{OA} = 0.61\mathbf{k} \text{ m}$$

$$\mathbf{P} = 267 \frac{-1.28\mathbf{i} - 0.61\mathbf{j} + 0.61\mathbf{k}}{\sqrt{(-1.28)^2 + (-0.61)^2 + 0.61^2}} = -221.3\mathbf{i} - 105.5\mathbf{j} + 105.5\mathbf{k} \text{ N}$$

$$\mathbf{Q} = 356 \frac{-0.61\mathbf{i} - 0.915\mathbf{j} + 0.61\mathbf{k}}{\sqrt{(-0.61)^2 + (-0.915)^2 + 0.61^2}} = -172.6\mathbf{i} - 258.9\mathbf{j} + 172.6\mathbf{k} \text{ N}$$

$$\mathbf{P} + \mathbf{Q} = -393.9\mathbf{i} - 364.4\mathbf{j} + 278.1\mathbf{k} \text{ N}$$

$$\therefore \mathbf{M}_O = \begin{vmatrix} \mathbf{i} & \mathbf{j} & \mathbf{k} \\ 0 & 0 & 0.61 \\ -393.9 & -364.4 & 278.1 \end{vmatrix} = 222.3\mathbf{i} - 240.3\mathbf{j} \text{ N}\cdot\text{m} \quad \blacktriangleleft$$

2.41

$$\mathbf{M}_O = \mathbf{r} \times \mathbf{F} \quad \mathbf{r} = -0.203\mathbf{i} + 0.305\mathbf{j} \text{ m} \quad \mathbf{F} = -534\mathbf{k} \text{ N}$$

$$\therefore \mathbf{M}_O = \begin{vmatrix} \mathbf{i} & \mathbf{j} & \mathbf{k} \\ -0.203 & 0.305 & 0 \\ 0 & 0 & -534 \end{vmatrix} = -192.9\mathbf{i} - 108.4\mathbf{j} \text{ N} \cdot \text{m} \blacklozenge$$

2.42

$$\mathbf{P} = -71 \cos 40^\circ \mathbf{i} + 71 \sin 40^\circ \mathbf{k} = -54.389\mathbf{i} + 45.638\mathbf{k} \text{ N} \quad \mathbf{Q} = -98.000\mathbf{j} \text{ N}$$

$$\therefore \mathbf{P} + \mathbf{Q} = -54.389\mathbf{i} - 98.000\mathbf{j} + 45.638\mathbf{k} \text{ N}$$

$$\mathbf{M}_O = \mathbf{r}_{OA} \times (\mathbf{P} + \mathbf{Q}) \quad \mathbf{r}_{OA} = -(0.076 + 0.203 \cos 40^\circ)\mathbf{i} + (0.203 \sin 40^\circ)\mathbf{k}$$

$$= -0.232\mathbf{i} + 0.130\mathbf{k} \text{ m}$$

$$\mathbf{M}_O = \begin{vmatrix} \mathbf{i} & \mathbf{j} & \mathbf{k} \\ -0.232 & 0 & 0.130 \\ -54.389 & -98.000 & 45.638 \end{vmatrix} = 12.788\mathbf{i} + 3.517\mathbf{j} + 22.736\mathbf{k} \text{ N} \cdot \text{m}$$

$$M_O = \sqrt{12.788^2 + 3.517^2 + 22.736^2} = 26.322 \text{ N} \cdot \text{m} \blacklozenge$$

$$\cos \theta_x = \frac{12.788}{26.322} = 0.4858; \quad \cos \theta_y = \frac{3.517}{26.322} = 0.1336; \quad \cos \theta_z = \frac{22.736}{26.322} = 0.8638 \blacklozenge$$

2.43

$$\mathbf{M}_O = \mathbf{r} \times \mathbf{F} = \begin{vmatrix} \mathbf{i} & \mathbf{j} & \mathbf{k} \\ x & 0 & z \\ 222 & -445 & -311 \end{vmatrix} = 445z\mathbf{i} + (311x + 222z)\mathbf{j} - 445x\mathbf{k}$$

Equating the x - and z -components of \mathbf{M}_O to the given values yields

$$445z = 542 \quad \therefore z = 1.22 \text{ m} \blacktriangleleft$$

$$-445x = -407 \quad \therefore x = 0.915 \text{ m} \blacktriangleleft$$

Check y -component:

$$311x + 222z = 311(0.915) + 222(1.22) = 555 \text{ N} \cdot \text{m} \text{ O.K.}$$

2.44

$$\mathbf{F} = 150 \cos 60^\circ \mathbf{j} + 150 \sin 60^\circ \mathbf{k} = 75\mathbf{j} + 129.90\mathbf{k} \text{ N}$$

$$\mathbf{r} = \overrightarrow{OB} = -50\mathbf{i} - 60\mathbf{j} \text{ mm}$$

$$\mathbf{M}_O = \mathbf{r} \times \mathbf{F} = \begin{vmatrix} \mathbf{i} & \mathbf{j} & \mathbf{k} \\ -50 & -60 & 0 \\ 0 & 75 & 129.90 \end{vmatrix} = -7794\mathbf{i} + 6495\mathbf{j} - 3750\mathbf{k} \text{ N} \cdot \text{mm}$$

$$M_O = \sqrt{(-7794)^2 + 6495^2 + (-3750)^2} = 10\,816 \text{ N} \cdot \text{mm} = 10.82 \text{ N} \cdot \text{m} \blacktriangleleft$$

$$d = \frac{M_O}{F} = \frac{10\,816}{150} = 72.1 \text{ mm} \blacktriangleleft$$

2.45

$$\mathbf{P}_1 = \frac{P}{\sqrt{2}}(\mathbf{j} - \mathbf{k}) \quad \mathbf{r}_1 = -d\mathbf{i} \quad \mathbf{P}_2 = \frac{P}{\sqrt{3}}(\mathbf{i} + \mathbf{j} - \mathbf{k}) \quad \mathbf{r}_2 = (a - d)\mathbf{i}$$

$$\mathbf{M}_A = \mathbf{r}_1 \times \mathbf{P}_1 + \mathbf{r}_2 \times \mathbf{P}_2 = \frac{P}{\sqrt{2}} \begin{vmatrix} \mathbf{i} & \mathbf{j} & \mathbf{k} \\ -d & 0 & 0 \\ 0 & 1 & -1 \end{vmatrix} + \frac{P}{\sqrt{3}} \begin{vmatrix} \mathbf{i} & \mathbf{j} & \mathbf{k} \\ (a-d) & 0 & 0 \\ 1 & 1 & -1 \end{vmatrix} = \mathbf{0}$$

Canceling P and expanding the determinants gives: $\frac{d}{\sqrt{2}}(-\mathbf{j} - \mathbf{k}) + \frac{a-d}{\sqrt{3}}(\mathbf{j} + \mathbf{k}) = \mathbf{0}$

Equating either the \mathbf{j} -components or the \mathbf{k} -components yields: $\frac{d}{\sqrt{2}} = \frac{a-d}{\sqrt{3}}$

from which we find: $d = \frac{a\sqrt{2}}{\sqrt{2} + \sqrt{3}} = 0.449a \quad \blacklozenge$

2.46

$$\mathbf{F} = 8.9\mathbf{i} - 53.4\mathbf{j} + 22.2\mathbf{k} \text{ lb}$$

$$\mathbf{r} = \overrightarrow{BA} = (-x + 0.61)\mathbf{i} + 0.915\mathbf{j} - z\mathbf{k}$$

$$\begin{aligned} \mathbf{M}_B = \mathbf{r} \times \mathbf{F} &= \begin{vmatrix} \mathbf{i} & \mathbf{j} & \mathbf{k} \\ -x + 0.61 & 0.915 & -z \\ 8.9 & -53.4 & 22.2 \end{vmatrix} \\ &= (-53.4z + 20.3)\mathbf{i} + (22.2x - 8.9z - 13.5)\mathbf{j} + (53.4x - 40.7)\mathbf{k} \end{aligned}$$

Setting \mathbf{i} and \mathbf{k} components to zero:

$$-53.4z + 20.3 = 0 \quad z = 0.380 \text{ m} \quad \blacktriangleleft$$

$$53.4x - 40.7 = 0 \quad x = 0.762 \text{ m} \quad \blacktriangleleft$$

Check \mathbf{j} component:

$$22.2x - 8.9z - 13.5 = 22.2(0.762) - 8.9(0.380) - 13.5 = 0 \text{ Checks!}$$

2.47

(a)

$$M_x = -75(0.85) = -63.75 \text{ kN} \cdot \text{m} \quad \blacktriangleleft$$

$$M_y = 75(0.5) = 37.5 \text{ kN} \cdot \text{m} \quad \blacktriangleleft$$

$$M_z = 160(0.5) = -90(0.85) = 3.5 \text{ kN} \cdot \text{m} \quad \blacktriangleleft$$

(b)

$$\mathbf{M}_O = \mathbf{r}_{OA} \times \mathbf{F} = \begin{vmatrix} \mathbf{i} & \mathbf{j} & \mathbf{k} \\ 0.5 & 0.85 & 0 \\ 90 & 160 & -75 \end{vmatrix} = -63.75\mathbf{i} + 37.5\mathbf{j} + 3.5\mathbf{k} \text{ kN} \cdot \text{m}$$

The components of \mathbf{M}_O agree with those computed in part (a).

2.48

(a)

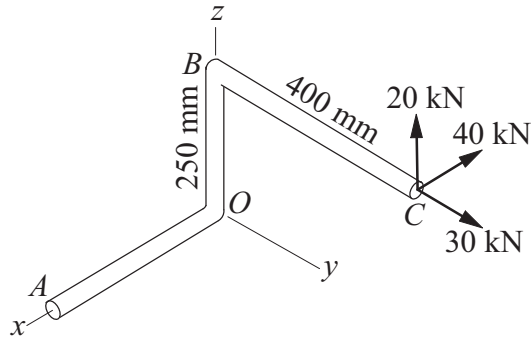

$$M_{OA} = 20(400) - 30(250) = 500 \text{ kN} \cdot \text{mm} = 500 \text{ N} \cdot \text{m} \quad \blacktriangleleft$$

(b)

$$\mathbf{F} = -40\mathbf{i} + 30\mathbf{j} + 20\mathbf{k} \text{ kN}$$

$$\mathbf{r} = \overrightarrow{OC} = 400\mathbf{j} + 250\mathbf{k} \text{ mm}$$

$$M_{OA} = \mathbf{r} \times \mathbf{F} \cdot \mathbf{i} = \begin{vmatrix} 0 & 400 & 250 \\ -40 & 30 & 20 \\ 1 & 0 & 0 \end{vmatrix} = 500 \text{ kN} \cdot \text{mm}$$

$$= 500 \text{ N} \cdot \text{m} \quad \blacktriangleleft$$

2.49

$$\overline{FG} = \sqrt{2.74^2 + 2.29^2} = 3.571 \text{ m}$$

$$P_x = 1780 \left(\frac{2.74}{3.571} \right) = 1366 \text{ N}$$

$$P_z = 1780 \left(\frac{2.29}{3.571} \right) = 1141 \text{ N}$$

(a)

$$\mathbf{M}_{AB} = P_z(\overline{AE})\mathbf{i} = 1141(1.22)\mathbf{i}$$

$$= 1392 \text{ N} \cdot \text{m}$$

(b)

$$\mathbf{M}_{CD} = P_z(\overline{CG})\mathbf{i} = 1141(1.22)\mathbf{i}$$

$$= 1392 \text{ N} \cdot \text{m}$$

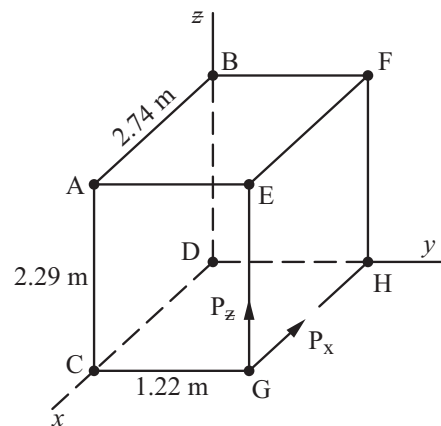

(c) $\mathbf{M}_{BF} = 0$ (because the force passes through F) \blacklozenge

(d) $\mathbf{M}_{DH} = -P_z(\overline{GH})\mathbf{j} = -1141(2.74)\mathbf{j} = -3126 \text{ N} \cdot \text{m} \quad \blacklozenge$

(e) $\mathbf{M}_{BD} = -P_x(\overline{DH})\mathbf{k} = 1366(1.22)\mathbf{k} = 1630 \text{ N} \cdot \text{m} \quad \blacklozenge$

2.50

(a)

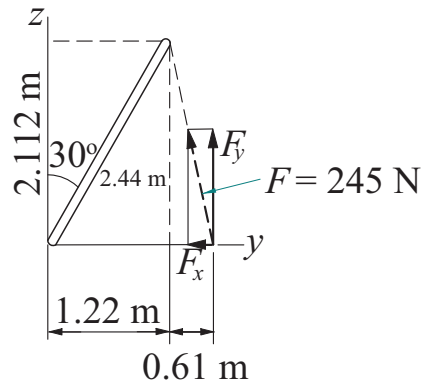

Only F_y has a moment about x -axis (since F_x intersects x -axis, it has no moment about that axis).

$$F_y = 245 \frac{2.112}{\sqrt{2.112^2 + 0.61^2}} = 235.4 \text{ N}$$

$$+ \circlearrowleft M_x = 1.83F_y = 1.83(235.4) = 431 \text{ N} \cdot \text{m} \quad \blacktriangleleft$$

(b)

$$\mathbf{F} = 245 \frac{-0.61\mathbf{j} + 2.112\mathbf{k}}{\sqrt{2.112^2 + 0.61^2}} = -68.0\mathbf{j} + 235.4\mathbf{k} \text{ N} \quad \mathbf{r} = 1.83\mathbf{j} \text{ m}$$

$$M_x = \mathbf{r} \times \mathbf{F} \cdot \boldsymbol{\lambda} = \begin{vmatrix} 0 & 1.83 & 0 \\ 0 & -68.0 & 235.4 \\ 1 & 0 & 0 \end{vmatrix} = 431 \text{ N} \cdot \text{m} \quad \blacktriangleleft$$

2.51

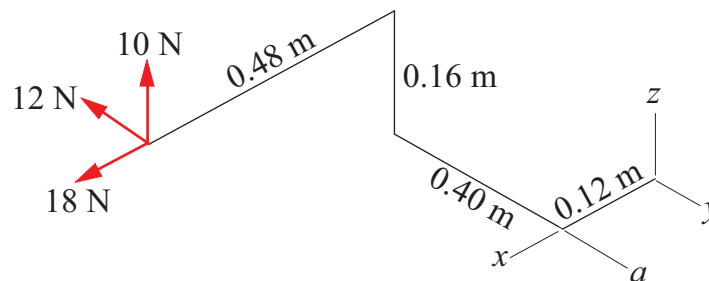

(a)

$$\mathbf{M}_a = [-10(0.48) + 18(0.16)]\mathbf{j} = -1.920\mathbf{j} \text{ N} \cdot \text{m} \quad \blacktriangleleft$$

(b)

$$\mathbf{M}_z = [-12(0.48 + 0.12) + 18(0.4)]\mathbf{k} = \mathbf{0} \quad \blacktriangleleft$$

2.52

(a)

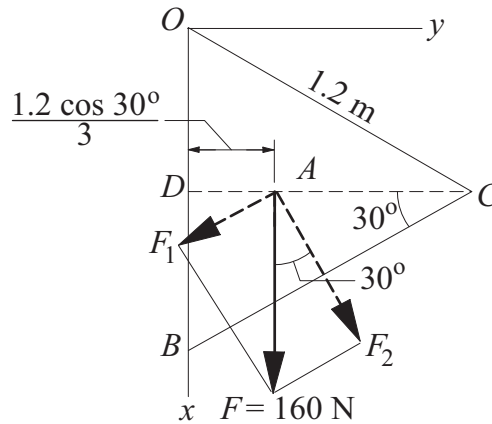

We resolve \mathbf{F} into components F_1 and F_2 , which are parallel and perpendicular to BC , respectively. Only F_2 contributes to M_{BC} :

$$M_{BC} = 1.8F_2 = 1.8(160 \cos 30^\circ) = 249 \text{ N} \cdot \text{m} \quad \blacktriangleleft$$

(b)

$$\mathbf{F} = 160\mathbf{i} \text{ N}$$

$$\mathbf{r} = \overrightarrow{BA} = -0.6\mathbf{i} + \frac{1.2 \cos 30^\circ}{3}\mathbf{j} + 1.8\mathbf{k} = -0.6\mathbf{i} + 0.3464\mathbf{j} + 1.8\mathbf{k} \text{ m}$$

$$\boldsymbol{\lambda}_{BC} = -\sin 30^\circ\mathbf{i} + \cos 30^\circ\mathbf{j} = -0.5\mathbf{i} + 0.8660\mathbf{j}$$

$$M_{BC} = \mathbf{r} \times \mathbf{F} \cdot \boldsymbol{\lambda}_{BC} = \begin{vmatrix} -0.6 & 0.3464 & 1.8 \\ 160 & 0 & 0 \\ -0.5 & 0.8660 & 0 \end{vmatrix} = 249 \text{ N} \cdot \text{m} \quad \blacktriangleleft$$

2.53

$$\mathbf{F} = -40\mathbf{i} - 8\mathbf{j} + 5\mathbf{k} \text{ N}$$

$$\mathbf{r} = 350 \sin 20^\circ\mathbf{i} - 350 \cos 20^\circ\mathbf{k} = 119.7\mathbf{i} - 328.9\mathbf{k} \text{ mm}$$

$$M_y = \mathbf{r} \times \mathbf{F} \cdot \mathbf{j} = \begin{vmatrix} 119.7 & 0 & -328.9 \\ -40 & -8 & 5 \\ 0 & 1 & 0 \end{vmatrix} = 12\,560 \text{ N} \cdot \text{mm}$$

$$= 12.56 \text{ N} \cdot \text{m} \quad \blacktriangleleft$$

2.54

$$M_y = (F + 18)(0.5) - (30 + 20)(0.5) = 0$$

$$\therefore F = \frac{25 - 9}{0.5} = 32.0 \text{ N} \quad \blacklozenge$$

$$M_x = (20 + 18)(0.6) - 30(0.6) - F(0.6 - d) = 0$$

Substituting $F = 32.0 \text{ N}$, and solving for d gives:

$$\therefore d = \frac{-22.8 + 18 + 32.0(0.6)}{32.0} = 0.450 \text{ m} \quad \blacklozenge$$

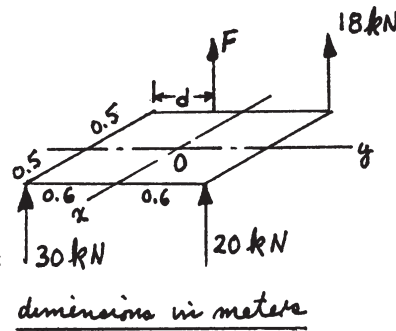

2.55

$$\begin{aligned} M_{aa} &= 133.5(1.22 - y_0) + 89(1.83 - y_0) - 178y_0 = 0 \quad \text{Solving gives: } y_0 = 0.813 \text{ m } \blacklozenge \\ M_{bb} &= (89 + 178)x_0 - 133.5(1.83 - x_0) = 0 \quad \text{Solving gives: } x_0 = 1.83 \text{ m } \blacklozenge \end{aligned}$$

2.56

With T acting at A , only the component T_z has a moment about the y -axis:
 $M_y = -1.22T_z$.

$$\begin{aligned} T_z &= T \frac{\overline{AB}_z}{AB} = 267 \frac{0.915}{\sqrt{1.22^2 + 1.22^2 + 0.915^2}} = 125.1 \text{ N} \\ \therefore M_y &= -1.22(125.1) = -152.6 \text{ N} \cdot \text{m } \blacktriangleleft \end{aligned}$$

2.57

Only the x -component of each force has a moment about the z -axis.

$$\begin{aligned} \therefore M_z &= (P \cos 30^\circ + Q \cos 25^\circ)0.381 \\ &= (142 \cos 30^\circ + 160 \cos 25^\circ)0.381 = 102.1 \text{ N} \cdot \text{m } \blacktriangleleft \end{aligned}$$

2.58

$$\begin{aligned} \mathbf{P} &= 360 \frac{-0.42\mathbf{i} - 0.81\mathbf{j} + 0.54\mathbf{k}}{\sqrt{(-0.42)^2 + (-0.81)^2 + 0.54^2}} = -142.6\mathbf{i} - 275.0\mathbf{j} + 183.4\mathbf{k} \text{ N} \\ \mathbf{r}_{CA} &= 0.42\mathbf{i} \text{ m} \quad \boldsymbol{\lambda}_{CD} = \frac{0.42\mathbf{i} + 0.54\mathbf{k}}{\sqrt{0.42^2 + 0.54^2}} = 0.6139\mathbf{i} + 0.7894\mathbf{k} \end{aligned}$$

$$M_{CD} = \mathbf{r}_{CA} \times \mathbf{P} \cdot \boldsymbol{\lambda}_{CD} = \begin{vmatrix} 0.42 & 0 & 0 \\ -142.6 & -275.0 & 183.4 \\ 0.6139 & 0 & 0.7894 \end{vmatrix} = -91.18 \text{ N} \cdot \text{m}$$

$$\begin{aligned} \mathbf{M}_{CD} &= M_{CD}\boldsymbol{\lambda}_{CD} = -91.18(0.6139\mathbf{i} + 0.7894\mathbf{k}) \\ &= -56.0\mathbf{i} - 72.0\mathbf{k} \text{ N} \cdot \text{m } \blacktriangleleft \end{aligned}$$

2.59

Let the 89-N force be \mathbf{Q} :

$$\mathbf{Q} = 89\vec{\lambda}_{ED} = 89 \left(\frac{-0.305\mathbf{j} - 0.101\mathbf{k}}{0.321} \right) = -84.6\mathbf{j} - 28.0\mathbf{k} \text{ N}$$

$$\mathbf{P} = P\vec{\lambda}_{AF} = P \left(\frac{-0.101\mathbf{i} + 0.101\mathbf{k}}{4\sqrt{2}} \right) = P(-0.707\mathbf{i} + 0.707\mathbf{k}) \text{ N}$$

$$M_{GB} = \mathbf{r}_{BE} \times \mathbf{Q} \cdot \vec{\lambda}_{GB} + \mathbf{r}_{BA} \times \mathbf{P} \cdot \vec{\lambda}_{GB} = 0$$

$$\mathbf{r}_{BE} = 0.101\mathbf{i} + 0.101\mathbf{k} \text{ m} \quad \mathbf{r}_{BA} = 0.101\mathbf{i} \text{ m} \quad \vec{\lambda}_{GB} = \left(\frac{0.305\mathbf{j} - 0.101\mathbf{k}}{0.321} \right)$$

$$M_{GB} = \frac{1}{0.321} \begin{vmatrix} 0.101 & 0 & 0.101 \\ 0 & -84.6 & -28.0 \\ 0 & 0.305 & -0.101 \end{vmatrix} + \frac{P}{0.321} \begin{vmatrix} 0.101 & 0 & 0 \\ -0.707 & 0 & 0.707 \\ 0 & 0.305 & -0.101 \end{vmatrix} = 0$$

$$\text{Expanding the determinants gives : } \frac{1.726}{0.321} + \frac{P}{0.321}(-0.022) = 0 \quad \therefore P = 78.46 \text{ N } \blacklozenge$$

2.60

$$M_{BC} = \mathbf{r}_{BA} \times \mathbf{F} \cdot \boldsymbol{\lambda}_{BC}$$

$$\mathbf{r}_{BA} = 1.52\mathbf{i} \quad \mathbf{F} = F \frac{-0.915\mathbf{i} + 0.915\mathbf{j} - 0.915\mathbf{k}}{\sqrt{(-0.915)^2 + 0.915^2 + (-0.915)^2}} = 0.5774F(-\mathbf{i} + \mathbf{j} - \mathbf{k})$$

$$\boldsymbol{\lambda}_{BC} = \frac{1.22\mathbf{j} - 0.610\mathbf{k}}{\sqrt{1.22^2 + (-0.610)^2}} = 0.8944\mathbf{j} - 0.4472\mathbf{k}$$

$$M_{BC} = \mathbf{r}_{BA} \times \mathbf{F} \cdot \boldsymbol{\lambda}_{BC} = 0.5774F \begin{vmatrix} 1.52 & 0 & 0 \\ -1 & 1 & -1 \\ 0 & 0.8944 & -0.4472 \end{vmatrix} = 0.315F$$

$$M_{BC} = 203 \text{ N} \cdot \text{m} \quad 0.315F = 203 \text{ N} \cdot \text{m} \quad F = 644 \text{ N} \quad \blacktriangleleft$$

2.61

The unit vector perpendicular to plane ABC is

$$\boldsymbol{\lambda} = \frac{\overrightarrow{AB} \times \overrightarrow{AC}}{|\overrightarrow{AB} \times \overrightarrow{AC}|}$$

$$\overrightarrow{AB} = (0.3\mathbf{i} - 0.5\mathbf{k}) \quad \overrightarrow{AC} = (0.4\mathbf{j} - 0.5\mathbf{k}) \text{ m}$$

$$\overrightarrow{AB} \times \overrightarrow{AC} = \begin{vmatrix} \mathbf{i} & \mathbf{j} & \mathbf{k} \\ 0.3 & 0 & -0.5 \\ 0 & 0.4 & -0.5 \end{vmatrix} = 0.2\mathbf{i} + 0.15\mathbf{j} + 0.12\mathbf{k}$$

$$\mathbf{F} = F\boldsymbol{\lambda} = 200 \frac{0.2\mathbf{i} + 0.15\mathbf{j} + 0.12\mathbf{k}}{\sqrt{0.2^2 + 0.15^2 + 0.12^2}}$$

$$= 144.24\mathbf{i} + 108.18\mathbf{j} + 86.55\mathbf{k} \text{ N} \cdot \text{m}$$

$$M_x = \overrightarrow{OA} \times \mathbf{F} \cdot \mathbf{i} = \begin{vmatrix} 0 & 0 & 0.5 \\ 144.24 & 108.18 & 86.55 \\ 1 & 0 & 0 \end{vmatrix} = -54.1 \text{ N} \cdot \text{m}$$

$$|M_x| = 54.1 \text{ N} \cdot \text{m} \quad \blacktriangleleft$$

2.62

$$\mathbf{P} = 1000\vec{\lambda}_{CE} = 1000 \left(\frac{-0.915\mathbf{i} + 0.61\mathbf{j} - 2.13\mathbf{k}}{\sqrt{5.746}} \right) \text{ N} \quad \vec{\lambda}_{AD} = \frac{-0.915\mathbf{i} + 1.83\mathbf{j} + 2.13\mathbf{k}}{\sqrt{8.732}}$$

(a) $\mathbf{r} = \mathbf{r}_{AC} = 1.83\mathbf{j} + 2.13\mathbf{k} \text{ m}$

$$M_{AD} = \mathbf{r}_{AC} \times \mathbf{P} \cdot \vec{\lambda}_{AD} = \frac{1000}{\sqrt{5.746}\sqrt{8.732}} \begin{vmatrix} 0 & 1.83 & 2.13 \\ -0.915 & 0.61 & -2.13 \\ -0.915 & 1.83 & 2.13 \end{vmatrix}$$

$$= \frac{1000}{\sqrt{5.746}\sqrt{8.732}} (4.755) = 672 \text{ N} \cdot \text{m} \quad \blacklozenge$$

(b) $\mathbf{r} = \mathbf{r}_{DC} = 0.915\mathbf{i} \text{ m}$

$$M_{AD} = \mathbf{r}_{DC} \times \mathbf{P} \cdot \vec{\lambda}_{AD} = \frac{1000}{\sqrt{5.746}\sqrt{8.732}} \begin{vmatrix} 0.915 & 0 & 0 \\ -0.915 & 0.61 & -2.13 \\ -0.915 & 1.83 & 2.13 \end{vmatrix}$$

$$= \frac{1000}{\sqrt{5.746}\sqrt{8.732}}(4.755) = 672 \text{ N} \cdot \text{m} \blacklozenge$$

2.63

Equating moments about the x - and y - axis:

$$2670(0.46) + 1780(0.61) + 890(1.22) = 5340y \quad y = 0.637 \text{ m} \blacktriangleleft$$

$$-2670(0.915) - 890(0.915) = -5340x \quad x = 0.61 \text{ m} \blacktriangleleft$$

2.64

$$\mathbf{M}_{BC} = \mathbf{M}_B \cdot \vec{\lambda}_{BC} = \mathbf{r}_{BD} \times \mathbf{F} \cdot \vec{\lambda}_{BC} = 0 \quad \mathbf{r}_{BD} = -1.6\mathbf{j} - (1.2 - z_D)\mathbf{k} \text{ m}$$

$$\mathbf{F} = F(0.6\mathbf{i} + 0.8\mathbf{j}) \quad \vec{\lambda}_{BC} = \frac{\vec{BC}}{|\vec{BC}|} = \frac{1.2\mathbf{i} - 0.6\mathbf{j} - 1.2\mathbf{k}}{1.8}$$

$$\therefore \mathbf{M}_{BC} = \frac{F}{1.8} \begin{vmatrix} 0 & -1.6 & -(1.2 - z_D) \\ 0.6 & 0.8 & 0 \\ 1.2 & -0.6 & -1.2 \end{vmatrix} = 0$$

Expanding the determinant: $1.6(0.6)(-1.2) - (1.2 - z_D)(-0.36 - 0.96) = 0$

which gives: $z_D = 0.327 \text{ m} \blacklozenge$

2.65

$$\vec{\lambda}_{AB} = \frac{-3\mathbf{i} + 4\mathbf{j}}{5} = -0.600\mathbf{i} + 0.800\mathbf{j}$$

For the pulley at A:

$$\mathbf{M}_A = \mathbf{M}_x = 20(0.5) - 60(0.5) = -20 \text{ kN}\cdot\text{m} \quad \therefore \mathbf{M}_A = -20\mathbf{i} \text{ kN}\cdot\text{m}$$

For the pulley at B:

$$\mathbf{M}_B = \mathbf{M}_y = 40(0.8) - 20(0.8) = 16 \text{ kN}\cdot\text{m} \quad \therefore \mathbf{M}_B = 16\mathbf{j} \text{ kN}\cdot\text{m}$$

For both pulleys combined:

$$\mathbf{M}_{AB} = (\mathbf{M}_A + \mathbf{M}_B) \cdot \vec{\lambda}_{AB} = (-20\mathbf{i} + 16\mathbf{j}) \cdot (-0.600\mathbf{i} + 0.800\mathbf{j})$$

$$= 12 + 12.8 = 24.8 \text{ kN}\cdot\text{m} \blacklozenge$$

2.66

From the figure at the right:

$$\begin{aligned}
 x_C &= 762 \sin 30^\circ = 381 \text{ mm} \\
 y_C &= 762 \cos 30^\circ - 610 = 50 \text{ mm} \\
 x_D &= 458 \sin 30^\circ = 229 \text{ mm} \\
 y_D &= 610 - 458 \cos 30^\circ = 213 \text{ mm} \\
 (M_B)_x &= \mathbf{r}_{BC} \times \mathbf{P}_C \cdot \mathbf{i} + \mathbf{r}_{BD} \times \mathbf{P}_D \cdot \mathbf{i} \\
 \mathbf{P}_C &= 88.9\mathbf{k} \text{ N} \quad \mathbf{P}_D = -88.9\mathbf{k} \text{ N} \\
 \mathbf{r}_{BC} &= x_C\mathbf{i} - y_C\mathbf{j} = 381\mathbf{i} - 50\mathbf{j} \text{ mm} \\
 \mathbf{r}_{BD} &= x_D\mathbf{i} + y_D\mathbf{j} = 229\mathbf{i} + 213\mathbf{j} \text{ mm}
 \end{aligned}$$

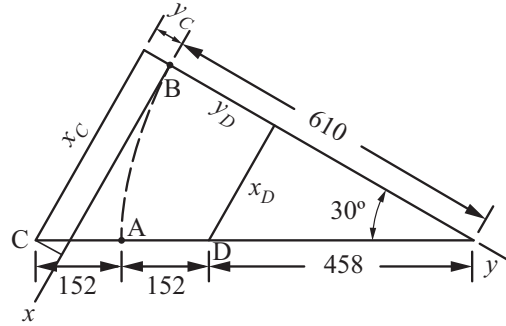

$$\therefore (M_B)_x = \begin{vmatrix} 381 & -50 & 0 \\ 0 & 0 & 88.9 \\ 1 & 0 & 0 \end{vmatrix} + \begin{vmatrix} 229 & 213 & 0 \\ 0 & 0 & -88.9 \\ 1 & 0 & 0 \end{vmatrix} = -4.445 - 18.94 = -23.38 \text{ N}\cdot\text{m}$$

Written in vector form: $(M_B)_x = (M_B)_x\mathbf{i} = -23.38\mathbf{i} \text{ N}\cdot\text{m} \blacklozenge$

2.67

(a)

$$\begin{aligned}
 \mathbf{F} &= 800 \frac{1.22\mathbf{i} + 2.44\mathbf{j} + 3.05\mathbf{k}}{\sqrt{1.22^2 + 2.44^2 + 3.05^2}} = 239\mathbf{i} + 477\mathbf{j} + 596\mathbf{k} \text{ N} \\
 \mathbf{r}_{BO} &= -1.83\mathbf{k} \text{ m} \quad \boldsymbol{\lambda}_{AB} = \frac{(-1.83 \cot 40^\circ)\mathbf{i} + 1.83\mathbf{k}}{\sqrt{(-1.83 \cot 40^\circ)^2 + 1.83^2}} = -0.7660\mathbf{i} + 0.6428\mathbf{k}
 \end{aligned}$$

$$M_{AB} = \mathbf{r}_{BO} \times \mathbf{F} \cdot \boldsymbol{\lambda}_{AB} = \begin{vmatrix} 0 & 0 & -1.83 \\ 239 & 477 & 596 \\ -0.7660 & 0 & 0.6428 \end{vmatrix} = -669 \text{ N}\cdot\text{m} \blacktriangleleft$$

(b)

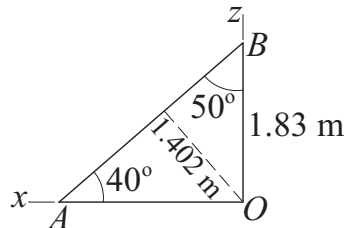

Note that only $F_y = 477 \text{ N}$ has a moment about AB . From trigonometry, the moment arm is $d = 1.83 \sin 50^\circ = 1.402 \text{ m}$.

$$\therefore M_{AB} = -F_y d = -477(1.402) = -669 \text{ N} \cdot \text{m} \quad \blacktriangleleft$$

2.68

Assume counterclockwise couples are positive.

(a) $C = -10(0.6) = -6 \text{ N} \cdot \text{m}$

(f) $C = -5(0.6) - 7.5(0.4) = -6 \text{ N} \cdot \text{m}$

(b) $C = -6 \text{ N} \cdot \text{m}$

(g) $C = -22.5(0.4) + 5(0.6) = -6 \text{ N} \cdot \text{m}$

(c) $C = -15(0.4) = -6 \text{ N} \cdot \text{m}$

(h) $C = -5 + 5(0.3) = -3.5 \text{ N} \cdot \text{m}$

(d) $C = -6 \text{ N} \cdot \text{m}$

(i) $C = 3 - 4 - 6 + 3 = -4 \text{ N} \cdot \text{m}$

(e) $C = 9 - 3 = 6 \text{ N} \cdot \text{m}$

2.69

(a) $C = -267(1.67)\mathbf{k} = -446\mathbf{k} \text{ N} \cdot \text{m}$

(b) $C = -334(1.33)\mathbf{k} = -444\mathbf{k} \text{ N} \cdot \text{m}$

(c) $C_1 = 334(1.67)\vec{\lambda}_1 = 558 \left(-\frac{1}{1.67} \mathbf{j} - \frac{1.33}{1.67} \mathbf{k} \right) = -334\mathbf{j} - 444\mathbf{k} \text{ N} \cdot \text{m}$

(d) $C = 445(1)\mathbf{i} = 445\mathbf{i} \text{ N} \cdot \text{m}$

(e) 334-N forces: $C_1 = 334\mathbf{j} - 444\mathbf{k} \text{ N} \cdot \text{m}$
[as in (c)]

200-N forces: $C_2 = 200(1.67)\mathbf{j} = 334\mathbf{j} \text{ N} \cdot \text{m}$

$$C_1 + C_2 = -444\mathbf{k} \text{ N} \cdot \text{m}$$

(f) 200-N forces: $C_3 = 200(1.33)\mathbf{i} = 266\mathbf{i} \text{ N} \cdot \text{m}$

222-N forces: $C_4 = 222(\sqrt{3.79})\vec{\lambda}_4$
 $= 222(\sqrt{3.79}) \left(\frac{-1\mathbf{i} - 1.67\mathbf{k}}{\sqrt{3.79}} \right)$
 $= -222\mathbf{i} - 370\mathbf{k} \text{ N} \cdot \text{m}$

$$C_3 + C_4 = 44\mathbf{i} - 370\mathbf{k} \text{ N} \cdot \text{m}$$

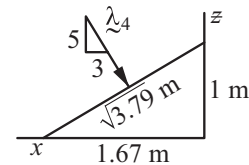
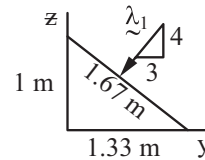
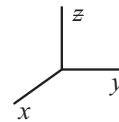

Because of metrication, (b) and (e) are no longer identical to (a). The differences (2 newtons) are not large, but the equality is no longer strictly true. \blacklozenge

2.70

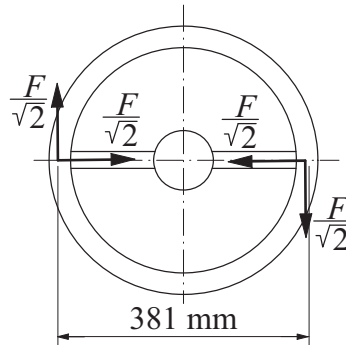

$$C = 0.381 \frac{F}{\sqrt{2}}$$

$$F = \frac{\sqrt{2}}{0.381} C = \frac{\sqrt{2}}{0.381} (13.56) = 50.3 \text{ N} \quad \blacktriangleleft$$

2.71

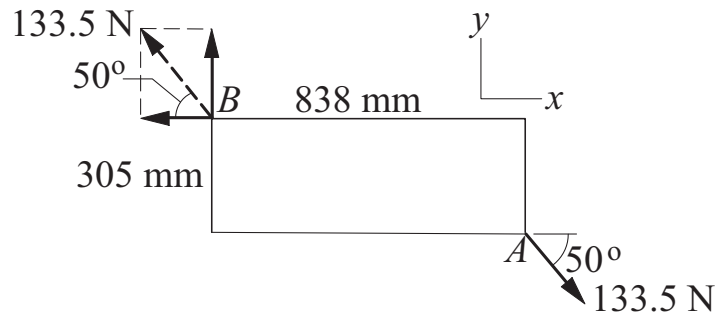

Choosing A as the moment center, we get

$$+\circlearrowleft \quad C = M_A = (133.5 \sin 50^\circ)(0.838) - (133.5 \cos 50^\circ)(0.305) \\ = 59.5 \text{ N} \cdot \text{m} \quad \blacktriangleleft$$

2.72

Choosing A as the moment center, we get

$$\mathbf{C} = \mathbf{M}_A = 267(0.915)\mathbf{i} + 267(0.61)\mathbf{j} - 133.5(0.61)\mathbf{j} - 133.5(0.915)\mathbf{k} \\ = 244\mathbf{i} + 81.4\mathbf{j} - 122\mathbf{k} \text{ N} \cdot \text{m} \quad \blacktriangleleft$$

2.73

$$\mathbf{C} = 60\boldsymbol{\lambda}_{DB} = 60 \frac{0.4\mathbf{i} - 0.3\mathbf{j} + 0.4\mathbf{k}}{\sqrt{0.4^2 + (-0.3)^2 + 0.4^2}} = 37.48\mathbf{i} - 28.11\mathbf{j} + 37.48\mathbf{k} \text{ N} \cdot \text{m}$$

$$\mathbf{P} = -300\mathbf{k} \text{ N} \quad \mathbf{r}_{AD} = -0.4\mathbf{i} \text{ m} \quad \boldsymbol{\lambda}_{AB} = \frac{-0.3\mathbf{i} + 0.4\mathbf{k}}{0.5} = -0.6\mathbf{j} + 0.8\mathbf{k}$$

Moment of the couple:

$$(M_{AB})_C = \mathbf{C} \cdot \boldsymbol{\lambda}_{AB} = -28.11(-0.6) + 37.48(0.8) = 46.85 \text{ N} \cdot \text{m}$$

Moment of the force:

$$(M_{AB})_P = \mathbf{r}_{AD} \times \mathbf{P} \cdot \boldsymbol{\lambda}_{AB} = \begin{vmatrix} -0.4 & 0 & 0 \\ 0 & 0 & -300 \\ 0 & -0.6 & 0.8 \end{vmatrix} = 72.0 \text{ N} \cdot \text{m}$$

Combined moment:

$$M_{AB} = (M_{AB})_C + (M_{AB})_P = 46.85 + 72.0 = 118.9 \text{ N} \cdot \text{m} \quad \blacktriangleleft$$

***2.74**

$$\mathbf{C}_1 = -22.6 \text{ N} \cdot \text{m} \quad \mathbf{C}_2 = 15.8 \text{ N} \cdot \text{m}$$

Identify the three points at the corners of the triangle:

$$\begin{aligned} &A(229 \text{ mm}, 76.2 \text{ mm}, 152.5 \text{ mm}); B(76.2 \text{ mm}, 178 \text{ mm}, 152.5 \text{ mm}); \\ &C(229 \text{ mm}, 178 \text{ mm}, 50.8 \text{ mm}) \end{aligned}$$

$\mathbf{C}_3 = 24.8\vec{\lambda} \text{ N} \cdot \text{m}$ where $\vec{\lambda}$ is the unit vector that is perpendicular to triangle ABC, with its sense consistent with the sense of \mathbf{C}_3 .

$$\vec{\lambda} = \frac{\overrightarrow{AC} \times \overrightarrow{AB}}{|\overrightarrow{AC} \times \overrightarrow{AB}|} \text{ where } \overrightarrow{AC} = 102\mathbf{j} - 102\mathbf{k} \text{ mm and } \overrightarrow{AB} = -153\mathbf{i} + 102\mathbf{j} \text{ mm}$$

$$\overrightarrow{AC} \times \overrightarrow{AB} = \begin{vmatrix} \mathbf{i} & \mathbf{j} & \mathbf{k} \\ 0 & 102 & -102 \\ -153 & 102 & 0 \end{vmatrix} = 10,404\mathbf{i} + 15,606\mathbf{j} + 15,606\mathbf{k} \text{ mm}^2$$

$$\therefore \vec{\lambda} = \frac{10,404\mathbf{i} + 15,606\mathbf{j} + 15,606\mathbf{k}}{24,400} = 0.426\mathbf{i} + 0.640\mathbf{j} + 0.640\mathbf{k}$$

$$\mathbf{C}_3 = 24.8(0.426\mathbf{i} + 0.640\mathbf{j} + 0.640\mathbf{k}) = 10.56\mathbf{i} + 15.87\mathbf{j} + 15.87\mathbf{k} \text{ N} \cdot \text{m}$$

$$\begin{aligned} \therefore \mathbf{C}^R &= \mathbf{C}_1 + \mathbf{C}_2 + \mathbf{C}_3 = -22.6\mathbf{i} + 15.8\mathbf{k} + (10.56\mathbf{i} + 15.87\mathbf{j} + 15.87\mathbf{k}) \text{ N} \cdot \text{m} \\ &= -12.04\mathbf{i} + 15.87\mathbf{j} + 31.67\mathbf{k} \text{ N} \cdot \text{m} \quad \blacklozenge \end{aligned}$$

2.75

Moment of a couple is the same about any point. Choosing B as the moment center, we have

$$\begin{aligned} \mathbf{F} &= -30\mathbf{i} \text{ kN} & \mathbf{r}_{BA} &= -1.8\mathbf{j} - 1.2\mathbf{k} \text{ m} \\ \mathbf{C} = \mathbf{M}_B &= \mathbf{r}_{BA} \times \mathbf{F} = \begin{vmatrix} \mathbf{i} & \mathbf{j} & \mathbf{k} \\ 0 & -1.8 & -1.2 \\ -30 & 0 & 0 \end{vmatrix} = 36.0\mathbf{j} - 54.0\mathbf{k} \text{ kN} \cdot \text{m} \quad \blacktriangleleft \end{aligned}$$

2.76

Moment of a couple is the same about any point. Choosing B as the moment center, we have

$$\mathbf{r}_{BA} = 180\mathbf{i} - b\mathbf{j} \text{ mm}$$

$$C_z = (M_B)_z = \mathbf{r}_{BA} \times \mathbf{F} \cdot \mathbf{k} = \begin{vmatrix} 180 & -b & 0 \\ 150 & -90 & 60 \\ 0 & 0 & 1 \end{vmatrix} = 150b - 16\,200 \text{ kN} \cdot \text{mm}$$

$$\therefore 150b - 16\,200 = 0 \quad b = 108.0 \text{ mm} \quad \blacktriangleleft$$

2.77

$$\begin{aligned} \mathbf{C} &= \mathbf{M}_A = 89(0.610)\mathbf{i} - 356(0.406)\mathbf{j} + 222(0.610)\mathbf{k} \\ &= 54.3\mathbf{i} - 145\mathbf{j} + 135\mathbf{k} \text{ N} \cdot \text{m} \quad \blacktriangleleft \end{aligned}$$

2.78

$$\mathbf{C} = -488 \cos 30^\circ \mathbf{i} - 488 \sin 30^\circ \mathbf{j} = -422.6\mathbf{i} - 244.0\mathbf{j} \text{ N} \cdot \text{m}$$

$$\vec{\lambda}_{CD} = -\cos 30^\circ \mathbf{i} - \sin 30^\circ \cos 40^\circ \mathbf{j} + \sin 30^\circ \sin 40^\circ \mathbf{k} = -0.8660\mathbf{i} - 0.3830\mathbf{j} + 0.3214\mathbf{k}$$

$$\therefore M_{CD} = \mathbf{C} \cdot \vec{\lambda}_{CD} = (-422.6)(-0.8660) + (-244.0)(-0.3830) = 459 \text{ N} \cdot \text{m} \quad \blacklozenge$$

2.79

$$\vec{\lambda}_{DC} = \sin 30^\circ \sin 40^\circ \mathbf{i} - \sin 30^\circ \cos 40^\circ \mathbf{j} + \cos 30^\circ \mathbf{k} = 0.3214\mathbf{i} - 0.3830\mathbf{j} + 0.8660\mathbf{k}$$

$$(a) \quad \mathbf{C} = 70.5 \vec{\lambda}_{DC} = 22.66\mathbf{i} - 27.00\mathbf{j} + 61.05\mathbf{k} \text{ N} \cdot \text{m} \quad \blacklozenge$$

$$(b) \quad \mathbf{M}_z = \mathbf{C}_z = 61.05\mathbf{k} \text{ N} \cdot \text{m} \quad \blacklozenge$$

2.80

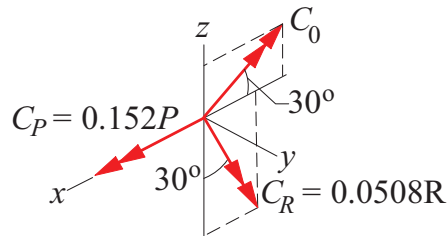

$$\mathbf{C}_P = 0.152P\mathbf{i} = 0.152(3335)\mathbf{i} = 507\mathbf{i} \text{ N} \cdot \text{m}$$

$$\mathbf{C}_0 = C_0(-\cos 30^\circ \mathbf{i} + \sin 30^\circ \mathbf{k}) = C_0(-0.8660\mathbf{i} + 0.50\mathbf{k})$$

$$\mathbf{C}_R = 0.0508R(-\sin 30^\circ \mathbf{i} - \cos 30^\circ \mathbf{k}) = -R(0.0254\mathbf{i} + 0.0440\mathbf{k})$$

$$\Sigma \mathbf{C} = (507 - 0.8660C_0 - 0.0254R)\mathbf{i} + (0.5C_0 - 0.0440R)\mathbf{k} = 0$$

Equating like components:

$$507 - 0.8660C_0 - 0.0254R = 0$$

$$0.5C_0 - 0.0440R = 0$$

The solution is:

$$R = 4990 \text{ N} \quad \leftarrow \quad C_0 = 439.1 \text{ N} \cdot \text{m} \quad \leftarrow$$

2.81

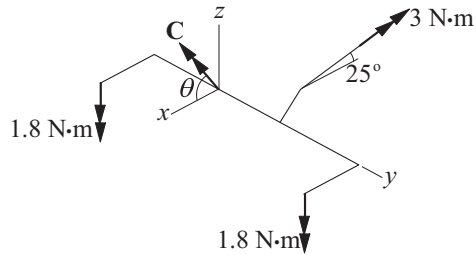

The system consists of the four couples shown, where

$$\mathbf{C} = 0.36F(\mathbf{i} \cos \theta + \mathbf{k} \sin \theta) \text{ N} \cdot \text{m}$$

$$\Sigma \mathbf{C} = -2(1.8)\mathbf{k} + 3(-\mathbf{i} \cos 25^\circ + \mathbf{k} \sin 25^\circ) + 0.36F(\mathbf{i} \cos \theta + \mathbf{k} \sin \theta) = \mathbf{0}$$

Equating like components:

$$-3 \cos 25^\circ + 0.36F \cos \theta = 0$$

$$-3.6 + 3 \sin 25^\circ + 0.36F \sin \theta = 0$$

$$F \cos \theta = \frac{3 \cos 25^\circ}{0.36} = 7.553$$

$$F \sin \theta = \frac{3.6 - 3 \sin 25^\circ}{0.36} = 6.478$$

$$\tan \theta = \frac{6.478}{7.553} = 0.8577 \quad \theta = 40.6^\circ \quad \leftarrow$$

$$F = \sqrt{7.553^2 + 6.478^2} = 9.95 \text{ N} \quad \leftarrow$$

2.82

Represent each of the systems by an equivalent force-couple system with the force acting at the upper left corner of the figure.

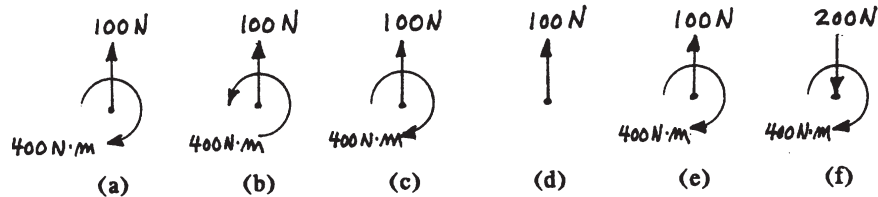

By inspection, the systems in (c) and (e) are equivalent to the system in (a). \blacklozenge

2.83

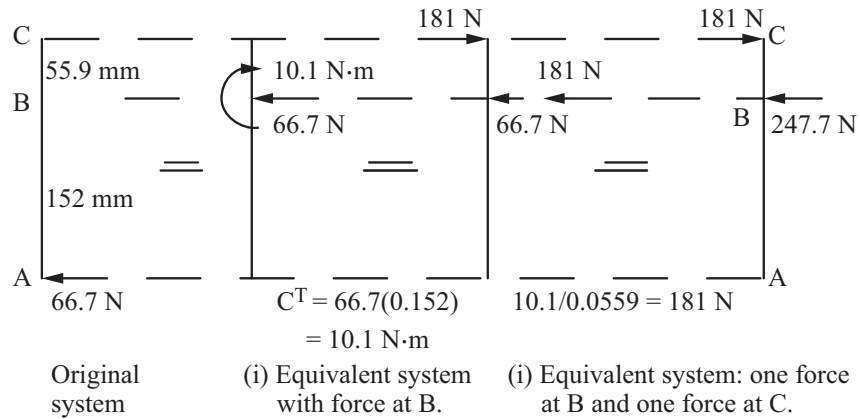

(a) Fig. (i): A 66.7-N force acting to the left at B, and a 10.1 N·m clockwise couple. ♦

(b) Fig. (ii): A 247.7-N force acting to the left at B, and a 181-N force acting to the right at C. ♦

2.84

(a)

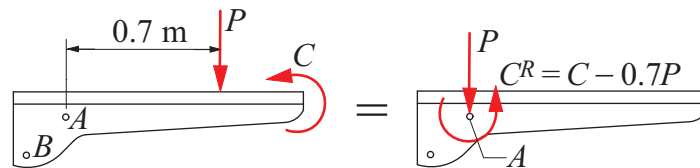

$$+ \downarrow R = P = 140 \text{ N down} \blacktriangleleft$$

$$+ \circlearrowleft C^R = \Sigma M_A = C - 0.7P = 180 - 0.7(140) = 82.0 \text{ N}\cdot\text{m CCW} \blacktriangleleft$$

(b)

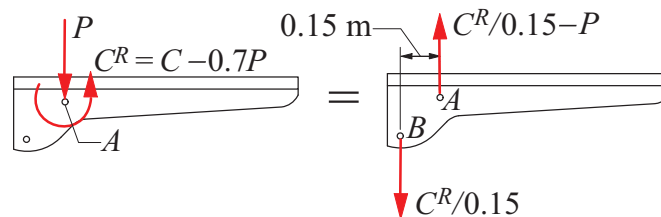

$$F_A = \frac{C^R}{0.15} - P = \frac{82}{0.15} - 140 = 407 \text{ N up} \blacktriangleleft$$

$$F_B = \frac{C^R}{0.15} = \frac{82}{0.15} = 547 \text{ N down} \blacktriangleleft$$

2.85

$$\begin{aligned} \downarrow R &= \Sigma F = 15 - 20 + 20 = 15 \text{ kN} \quad \blacktriangleleft \\ + \circlearrowleft C^R &= \Sigma M_A = 15(3) - 20(6) + 20(8) = 85 \text{ kN} \cdot \text{m} \quad \blacktriangleleft \end{aligned}$$

2.86

$$\begin{aligned} \mathbf{R} &= -400\mathbf{j} + 222(\mathbf{i} \sin 30^\circ - \mathbf{j} \cos 30^\circ) = 111\mathbf{i} - 592\mathbf{j} \text{ lb} \quad \blacktriangleleft \\ + \circlearrowleft C^R &= 400(0.229) - 222(0.305) = 83.8 \text{ N} \cdot \text{m} \quad \mathbf{C}^R = 83.8\mathbf{k} \text{ N} \cdot \text{m} \quad \blacktriangleleft \end{aligned}$$

2.87

The resultant force R equals V .

$$\therefore V = R = 6320 \text{ N} \quad \blacktriangleleft$$

$$\begin{aligned} C^R = \Sigma M_D = 0 : \quad 0.508V - 0.254H - C &= 0 \\ 0.508(6320) - 0.254H - 1020 &= 0 \quad H = 8620 \text{ N} \quad \blacktriangleleft \end{aligned}$$

2.88

$$\begin{aligned} \mathbf{R} &= -250\mathbf{k} \text{ N} \quad \blacktriangleleft \\ \mathbf{C}^R &= \mathbf{M}_O = -250(1.2)\mathbf{i} + 250(0.8)\mathbf{j} \\ &= -300\mathbf{i} + 200\mathbf{j} \text{ N} \cdot \text{m} \quad \blacktriangleleft \\ C^R &= \sqrt{(-300)^2 + 200^2} = 361 \text{ N} \cdot \text{m} \end{aligned}$$

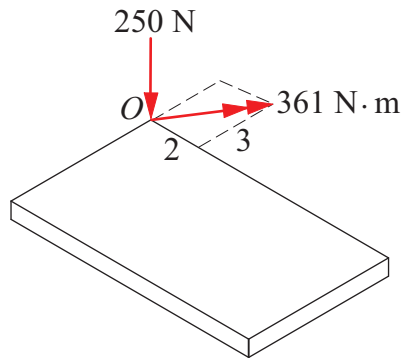

2.89

$$\begin{aligned} \mathbf{F} &= 270\lambda_{AB} = 270 \frac{-2.2\mathbf{i} + 2.0\mathbf{j} - 2.0\mathbf{k}}{\sqrt{(-2.2)^2 + 2.0^2 + (-2.0)^2}} \\ &= -165.8\mathbf{i} + 150.7\mathbf{j} - 150.7\mathbf{k} \text{ kN} \quad \blacktriangleleft \\ \mathbf{C}^R &= \mathbf{r}_{OB} \times \mathbf{F} = \begin{vmatrix} \mathbf{i} & \mathbf{j} & \mathbf{k} \\ 0 & 2 & 0 \\ -165.8 & 150.7 & -150.7 \end{vmatrix} = -301\mathbf{i} + 332\mathbf{k} \text{ kN} \cdot \text{m} \quad \blacktriangleleft \end{aligned}$$

2.90

$$178\text{-N force: } \mathbf{P} = 178 \frac{-0.915\mathbf{i} - 0.61\mathbf{k}}{\sqrt{(-0.915)^2 + (-0.61)^2}} = -148\mathbf{i} - 98.7\mathbf{k} \text{ N}$$

$$122 \text{ N} \cdot \text{m couple: } \mathbf{C} = 122 \frac{-0.915\mathbf{i} - 1.52\mathbf{j}}{\sqrt{(-0.915)^2 + (-1.52)^2}} = -62.9\mathbf{i} - 105\mathbf{j} \text{ N} \cdot \text{m}$$

$$\mathbf{r}_{OA} = 0.915\mathbf{i} + 1.52\mathbf{j} \text{ m}$$

$$\mathbf{R} = \mathbf{P} = -148.1\mathbf{i} - 98.7\mathbf{k} \text{ N} \quad \blacktriangleleft$$

$$\mathbf{C}^R = \mathbf{C} + \mathbf{r}_{OA} \times \mathbf{P} = -62.9\mathbf{i} - 105\mathbf{j} + \begin{vmatrix} \mathbf{i} & \mathbf{j} & \mathbf{k} \\ 0.915 & 1.52 & 0 \\ -148 & 0 & -98.7 \end{vmatrix}$$

$$= -87.1\mathbf{i} - 195\mathbf{j} + 225\mathbf{k} \text{ N} \cdot \text{m} \quad \blacktriangleleft$$

*2.91

(a)

$$\mathbf{R} = \mathbf{F} = -12\,500\mathbf{i} + 7120\mathbf{j} + 13\,340\mathbf{k} \text{ N} \quad \blacktriangleleft$$

$$\mathbf{r}_{OA} = 0.225\mathbf{i} + 0.152\mathbf{j} - 0.102\mathbf{k} \text{ m}$$

$$\mathbf{C}^R = \mathbf{r}_{OA} \times \mathbf{F} = \begin{vmatrix} \mathbf{i} & \mathbf{j} & \mathbf{k} \\ 0.225 & 0.152 & -0.102 \\ -12\,500 & 7120 & 13\,340 \end{vmatrix}$$

$$= 3928\mathbf{i} - 1725\mathbf{j} + 3500\mathbf{k} \text{ N} \cdot \text{m} \quad \blacktriangleleft$$

(b)

$$\text{Normal component of } \mathbf{R}: P = |R_y| = 7120 \text{ N} \quad \blacktriangleleft$$

$$\text{Shear component of } \mathbf{R}: V = \sqrt{R_x^2 + R_z^2} = \sqrt{(-12\,500)^2 + 13\,340^2}$$

$$= 18\,280 \text{ N} \quad \blacktriangleleft$$

(c)

$$\text{Torque: } T = |C_y^R| = 1725 \text{ N} \cdot \text{m} \quad \blacktriangleleft$$

$$\text{Bending moment: } M = \sqrt{(C_x^R)^2 + (C_z^R)^2} = \sqrt{3928^2 + 3500^2}$$

$$= 5260 \text{ N} \cdot \text{m} \quad \blacktriangleleft$$

2.92

$$\vec{\lambda}_{DC} = \sin 30^\circ \sin 40^\circ \mathbf{i} - \sin 30^\circ \cos 40^\circ \mathbf{j} + \cos 30^\circ \mathbf{k}$$

$$= 0.3214\mathbf{i} - 0.3830\mathbf{j} + 0.8660\mathbf{k}$$

The force at O equals the original force:

$$\mathbf{F} = 45\vec{\lambda}_{DC} = 45(0.3214\mathbf{i} - 0.3830\mathbf{j} + 0.8660\mathbf{k}) = 14.46\mathbf{i} - 17.24\mathbf{j} + 38.97\mathbf{k} \text{ N}$$

The given couple is:

$$\mathbf{C} = 70.5\vec{\lambda}_{DC} = 70.5(0.3214\mathbf{i} - 0.3830\mathbf{j} + 0.8660\mathbf{k}) = 22.66\mathbf{i} - 27.00\mathbf{j} + 61.05\mathbf{k} \text{ N} \cdot \text{m}$$

Moving the force to O, and letting \mathbf{C}^R be the resultant couple, we have: $\mathbf{C}^R = \mathbf{C} + \mathbf{M}_O$

$$\begin{aligned} \mathbf{M}_O = \mathbf{r}_{OD} \times \mathbf{F} \quad \mathbf{r}_{OD} &= -1.28 \sin 40^\circ \mathbf{i} + 1.28 \cos 40^\circ \mathbf{j} + 0.850\mathbf{k} \\ &= -0.823\mathbf{i} + 0.981\mathbf{j} + 0.850\mathbf{k} \text{ m} \end{aligned}$$

$$\mathbf{M}_O = \begin{vmatrix} \mathbf{i} & \mathbf{j} & \mathbf{k} \\ -0.823 & 0.981 & 0.850 \\ 14.46 & -17.24 & 38.97 \end{vmatrix} = 52.88\mathbf{i} + 44.36\mathbf{j} \text{ N} \cdot \text{m}$$

$$\begin{aligned} \therefore \mathbf{C}^R &= \mathbf{C} + \mathbf{M}_O = (22.66\mathbf{i} - 27.00\mathbf{j} + 61.05\mathbf{k}) + (52.88\mathbf{i} + 44.36\mathbf{j}) \\ &= 75.54\mathbf{i} + 17.36\mathbf{j} + 61.05\mathbf{k} \text{ N} \cdot \text{m} \end{aligned}$$

The equivalent force-couple system with the force acting at O is:

$$\text{Force : } 14.46\mathbf{i} - 17.24\mathbf{j} + 38.97\mathbf{k} \text{ N; Couple : } 75.54\mathbf{i} + 17.36\mathbf{j} + 61.05\mathbf{k} \text{ N} \cdot \text{m} \blacktriangleleft$$

2.93

$$\mathbf{F} = 600 \frac{-1.2\mathbf{i} + 0.8\mathbf{k}}{\sqrt{(-1.2)^2 + 0.8^2}} = -499.2\mathbf{i} + 332.8\mathbf{k} \text{ N}$$

$$\mathbf{C} = 1200 \frac{-1.2\mathbf{i} + 1.8\mathbf{j}}{\sqrt{(1.2)^2 + 1.8^2}} = -665.6\mathbf{i} + 998.5\mathbf{k} \text{ N} \cdot \text{m}$$

$$\mathbf{r}_{BA} = 1.2\mathbf{i} - 1.8\mathbf{j} \text{ m}$$

$$\mathbf{R} = \mathbf{F} = -499.2\mathbf{i} + 332.8\mathbf{k} \text{ N} \blacktriangleleft$$

$$\begin{aligned} \mathbf{C}^R &= \mathbf{r}_{BA} \times \mathbf{F} + \mathbf{C} = \begin{vmatrix} \mathbf{i} & \mathbf{j} & \mathbf{k} \\ 1.2 & -1.8 & 0 \\ -499.2 & 0 & 332.8 \end{vmatrix} + \mathbf{C} \\ &= (-599.0\mathbf{i} - 399.4\mathbf{j} - 898.6\mathbf{k}) + (-665.6\mathbf{i} + 998.5\mathbf{k}) \\ &= -1265\mathbf{i} - 399\mathbf{j} + 100\mathbf{k} \text{ N} \cdot \text{m} \blacktriangleleft \end{aligned}$$

2.94

$$M_{AB} = \mathbf{r}_{AO} \times \mathbf{P} \cdot \boldsymbol{\lambda}_{AB} = 1150 \text{ N} \cdot \text{m} \quad \mathbf{r}_{AO} = -2.44\mathbf{j} \text{ m}$$

$$\mathbf{P} = P(\cos 20^\circ \mathbf{i} + \sin 20^\circ \mathbf{k}) \quad \boldsymbol{\lambda}_{AB} = -\cos 30^\circ \mathbf{i} + \sin 30^\circ \mathbf{k}$$

$$M_{AB} = P \begin{vmatrix} 0 & -2.44 & 0 \\ \cos 20^\circ & 0 & \sin 20^\circ \\ -\cos 30^\circ & 0 & \sin 30^\circ \end{vmatrix} = 1.869P$$

$$1.869P = 1150 \text{ N} \cdot \text{m} \quad P = 615 \text{ N} \blacktriangleleft$$

2.95

Given force and couple:

$$\mathbf{F} = 32 \frac{-3\mathbf{i} - 4\mathbf{j} + 6\mathbf{k}}{\sqrt{(-3)^2 + (-4)^2 + 6^2}} = -12.292\mathbf{i} - 16.389\mathbf{j} + 24.58\mathbf{k} \text{ kN}$$

$$\mathbf{C} = 180 \frac{3\mathbf{i} - 4\mathbf{j}}{\sqrt{3^2 + (-4)^2}} = 108.0\mathbf{i} - 144.0\mathbf{j} \text{ kN} \cdot \text{m}$$

Equivalent force-couple system at A :

$$\begin{aligned} \mathbf{R} &= \mathbf{F} = -12.29\mathbf{i} - 16.39\mathbf{j} + 24.6\mathbf{k} \text{ kN} \quad \blacktriangleleft \\ \mathbf{C}^R &= \mathbf{C} + \mathbf{r}_{AB} \times \mathbf{F} = 108.0\mathbf{i} - 144.0\mathbf{j} + \begin{vmatrix} \mathbf{i} & \mathbf{j} & \mathbf{k} \\ -3 & 4 & 0 \\ -12.292 & -16.389 & 24.58 \end{vmatrix} \\ &= 206\mathbf{i} - 70.3\mathbf{j} + 98.3\mathbf{k} \text{ kN} \cdot \text{m} \quad \blacktriangleleft \end{aligned}$$

2.96

$$\mathbf{T}_1 = 60 \frac{-3\mathbf{i} - 7\mathbf{j}}{\sqrt{(-3)^2 + (-7)^2}} = -23.64\mathbf{i} - 55.15\mathbf{j} \text{ kN}$$

$$\mathbf{T}_2 = 60 \frac{6\mathbf{i} - 7\mathbf{j}}{\sqrt{6^2 + (-7)^2}} = 39.05\mathbf{i} - 45.56\mathbf{j} \text{ kN}$$

$$\mathbf{T}_3 = 60 \frac{-3\mathbf{i} - 2\mathbf{j}}{\sqrt{(-3)^2 + (-2)^2}} = -49.92\mathbf{i} - 33.28\mathbf{j} \text{ kN}$$

$$\begin{aligned} \mathbf{R} &= \Sigma \mathbf{T} = (-23.64 + 39.05 - 49.92)\mathbf{i} + (-55.15 - 45.56 - 33.28)\mathbf{j} \\ &= -34.51\mathbf{i} - 133.99\mathbf{j} \text{ kN} \quad \blacktriangleleft \end{aligned}$$

Noting that only the x -components of the tensions contribute to the moment about O :

$$\mathbf{C}^R = \Sigma \mathbf{M}_O = [7(23.64) - 7(39.05) + 2(49.92)] \mathbf{k} = -8.03\mathbf{k} \text{ kN} \cdot \text{m} \quad \blacktriangleleft$$

2.97

$$\begin{aligned} \mathbf{M}_O &= \mathbf{r}_{OA} \times \mathbf{F} = \begin{vmatrix} \mathbf{i} & \mathbf{j} & \mathbf{k} \\ b & 0.25 & 0.3 \\ 10 & 20 & -5 \end{vmatrix} \\ &= -7.25\mathbf{i} + (3 + 5b)\mathbf{j} + (-2.5 + 20b)\mathbf{k} \text{ kN} \cdot \text{m} \\ M_y &= 3 + 5b = 8 \quad \therefore b = 1.0 \text{ m} \quad \blacktriangleleft \\ \mathbf{M}_O &= -7.25\mathbf{i} + 8\mathbf{j} + 17.5\mathbf{k} \text{ kN} \cdot \text{m} \quad \blacktriangleleft \end{aligned}$$

2.98

$$\mathbf{M}_{CD} = \mathbf{r}_{CA} \times \mathbf{P} \bullet \vec{\lambda}_{CD} = 5.65 \text{ N} \cdot \text{m}$$

$$\mathbf{r}_{CA} = 0.1524\mathbf{i} - 0.0508\mathbf{j} \text{ m} \quad \mathbf{P} = P\vec{\lambda}_{AB} = P \left(\frac{-0.0762\mathbf{i} - 0.0508\mathbf{j} + 0.1270\mathbf{k}}{\sqrt{0.025}} \right) \text{ N}$$

$$\vec{\lambda}_{CD} = \frac{-0.1016\mathbf{j} + 0.1270\mathbf{k}}{\sqrt{0.026}}$$

Using the determinant form of the scalar triple product:

$$\begin{aligned} \mathbf{M}_{CD} &= \frac{P}{\sqrt{0.025}\sqrt{0.026}} \begin{vmatrix} 0.1524 & -0.0508 & 0 \\ -0.0762 & -0.0508 & 0.1270 \\ 0 & -0.1016 & 0.1270 \end{vmatrix} \\ &= \frac{P}{\sqrt{0.025}\sqrt{0.026}} [0.1524(-0.00645 + 0.0129) + 0.0508(0.00968)] = 5.65 \text{ N} \cdot \text{m} \end{aligned}$$

$$\text{Solving for } P \text{ gives: } P = \frac{5.65\sqrt{0.025}\sqrt{0.026}}{0.000492} = 294 \text{ N} \blacklozenge$$

2.99

$$\mathbf{F} = -160\mathbf{i} - 120\mathbf{j} + 90\mathbf{k} \text{ N}$$

$$\mathbf{r} = \vec{BA} = -0.36\mathbf{i} + 0.52\mathbf{j} - 0.48 \text{ k m}$$

$$\begin{aligned} \mathbf{C} = \mathbf{M}_B = \mathbf{r} \times \mathbf{F} &= \begin{vmatrix} \mathbf{i} & \mathbf{j} & \mathbf{k} \\ -0.36 & 0.52 & -0.48 \\ -160 & -120 & 90 \end{vmatrix} \\ &= -10.80\mathbf{i} + 109.2\mathbf{j} + 126.4\mathbf{k} \text{ N} \cdot \text{m} \blacktriangleleft \end{aligned}$$

2.100

(a)

$$\mathbf{M}_O = \mathbf{r}_{OA} \times \mathbf{P} + \mathbf{C} \quad \mathbf{r}_{OA} = 1.22\mathbf{k} \text{ m}$$

$$\mathbf{P} = 3600 \frac{0.915\mathbf{i} - 1.22\mathbf{k}}{1.525} = 2160\mathbf{i} - 2880\mathbf{k} \text{ N} \quad \mathbf{C} = 2000\mathbf{k} \text{ N} \cdot \text{m}$$

$$\mathbf{M}_O = \begin{vmatrix} \mathbf{i} & \mathbf{j} & \mathbf{k} \\ 0 & 0 & 1.22 \\ 2160 & 0 & -2880 \end{vmatrix} + 2000\mathbf{k} = 2635\mathbf{j} + 2000\mathbf{k} \text{ N} \cdot \text{m} \blacktriangleleft$$

(b)

$$\begin{aligned} M_{OF} &= \mathbf{M}_O \cdot \boldsymbol{\lambda}_{OF} = (2635\mathbf{j} + 2000\mathbf{k}) \cdot \frac{0.915\mathbf{i} + 3.66\mathbf{j} + 1.22\mathbf{k}}{3.965} \\ &= \frac{2635(3.66) + 2000(1.22)}{3.965} = 3050 \text{ N} \cdot \text{m} \blacktriangleleft \end{aligned}$$

2.101

$$R_x = \Sigma F_x = T_1 \sin 45^\circ - T_3 \sin 30^\circ = 0$$

$$R_y = \Sigma F_y = T_1 \cos 45^\circ + T_3 \cos 30^\circ + 1110 = 3330$$

The solution is

$$T_1 = 1150 \text{ N} \quad \blacktriangleleft \quad T_3 = 1625 \text{ N} \quad \blacktriangleleft$$

2.102

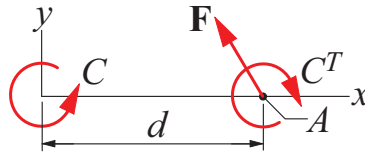

Transferring \mathbf{F} to point A introduces the couple of transfer C^T which is equal to the moment of the original \mathbf{F} about point A :

$$C^T = F_y d = 1335d$$

The couples C and C^T cancel out if

$$C = C^T \quad 815 = 1335d \quad d = 1.64 \text{ m} \quad \blacktriangleleft$$

2.103

$$\mathbf{R} = \Sigma \mathbf{F} = 40\mathbf{i} + 30\mathbf{k} \text{ kN} \quad \blacktriangleleft$$

$$\mathbf{r}_{OA} = 0.8\mathbf{i} + 1.2\mathbf{j} \text{ m}$$

$$\mathbf{C}^R = \Sigma \mathbf{M}_O = \mathbf{r}_{OA} \times \mathbf{R} = \begin{vmatrix} \mathbf{i} & \mathbf{j} & \mathbf{k} \\ 0.8 & 1.2 & 0 \\ 40 & 0 & 30 \end{vmatrix} = 36\mathbf{i} - 24\mathbf{j} - 48\mathbf{k} \text{ kN} \cdot \text{m} \quad \blacktriangleleft$$

2.104

$$\rightarrow \mathbf{R}_x = \Sigma \mathbf{F}_x = \mathbf{P} - \mathbf{P} = 0$$

$$+\uparrow \mathbf{R}_y = \Sigma \mathbf{F}_y = \mathbf{P}$$

Therefore, the force acting at A is $\mathbf{R} = \mathbf{P}$ (acting upward) \blacklozenge

Because \mathbf{R} passes through point A , the moment of the three forces about A is zero.

$$\curvearrowright \Sigma \mathbf{M}_A = \mathbf{P}(L-x) - \mathbf{P}(L/2) = 0 \quad \text{which gives } x = L/2 \quad \blacklozenge$$

2.105

Because the resultant force passes through O and there is no resultant couple, the combined moment of the two forces about O is zero.

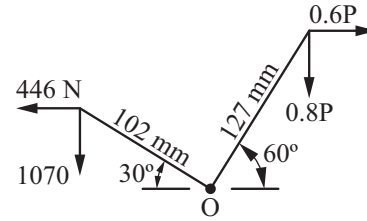

$$\begin{aligned} \sum M_O &= 1070(0.102 \cos 30^\circ) + 446(0.102 \sin 30^\circ) - 0.8P(0.127 \cos 60^\circ) \\ &\quad - 0.6P(0.127 \sin 60^\circ) = 0 \end{aligned}$$

Solving for P gives: $P = 1004 \text{ N}$ ♦

2.106

$$\vec{BA} = -0.91\mathbf{i} - 0.915 \cos 20^\circ\mathbf{j} + (1.22 - 0.915 \sin 20^\circ)\mathbf{k} = 0.91\mathbf{i} - 0.860\mathbf{j} + 0.907\mathbf{k} \text{ N}$$

$$\vec{CA} = -0.61\mathbf{i} - 0.860\mathbf{j} + 0.907\mathbf{k} \text{ N}$$

$$\mathbf{T}_1 = 133\vec{\lambda}_{BA} = 133 \left(\frac{0.91\mathbf{i} - 0.860\mathbf{j} + 0.907\mathbf{k}}{1.546} \right) = -78.3\mathbf{i} - 74.0\mathbf{j} + 78.0\mathbf{k} \text{ N}$$

$$\mathbf{T}_2 = 400\vec{\lambda}_{CA} = 400 \left(\frac{-0.61\mathbf{i} - 0.860\mathbf{j} + 0.907\mathbf{k}}{1.391} \right) = 175\mathbf{i} - 247\mathbf{j} + 261\mathbf{k} \text{ N}$$

$$\mathbf{R} = \mathbf{T}_1 + \mathbf{T}_2 = 96.7\mathbf{i} - 321\mathbf{j} + 339\mathbf{k} \text{ N}$$

$$\therefore R = \sqrt{0.150^2 + (-1.174)^2 + 1.239^2} = 477 \text{ N} \text{ ♦}$$

2.107

$$\mathbf{F} = -1780\mathbf{i} + 1335\mathbf{j} + 1110\mathbf{k} \text{ N}$$

$$\mathbf{C} = C \frac{-0.915\mathbf{j} + 1.22\mathbf{k}}{1.525} = C(-0.6\mathbf{j} + 0.8\mathbf{k})$$

$$\mathbf{r}_{DA} = 0.915\mathbf{j} \text{ ft} \quad \boldsymbol{\lambda}_{DE} = -0.6\mathbf{i} + 0.8\mathbf{k}$$

$$(M_{DE})_P = \mathbf{r}_{DA} \times \mathbf{F} \cdot \boldsymbol{\lambda}_{DE} = \begin{vmatrix} 0 & 0.915 & 0 \\ -1780 & 1335 & 1110 \\ -0.6 & 0 & 0.8 \end{vmatrix} = 694 \text{ N} \cdot \text{m}$$

$$(M_{DE})_C = \mathbf{C} \cdot \boldsymbol{\lambda}_{DE} = C(-0.6\mathbf{j} + 0.8\mathbf{k}) \cdot (-0.6\mathbf{i} + 0.8\mathbf{k}) = 0.64C$$

$$M_{DE} = (M_{DE})_P + (M_{DE})_C = 1625 \text{ N} \cdot \text{m}$$

$$694 + 0.64C = 1625 \quad C = 1455 \text{ N} \cdot \text{m} \blacktriangleleft$$

2.108

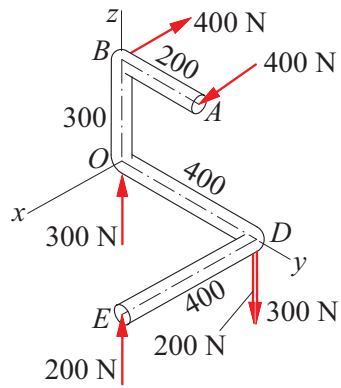

Split the 500-N force at D into the 200-N and 300-N forces as shown. We now see that the force system consists of three couples.

$$\begin{aligned} \mathbf{C}^R &= \Sigma \mathbf{C} = -300(0.4)\mathbf{i} - 200(0.4)\mathbf{j} - 400(0.2)\mathbf{k} \\ &= -120\mathbf{i} - 80\mathbf{j} - 80\mathbf{k} \text{ N} \cdot \text{m} \quad \blacktriangleleft \end{aligned}$$

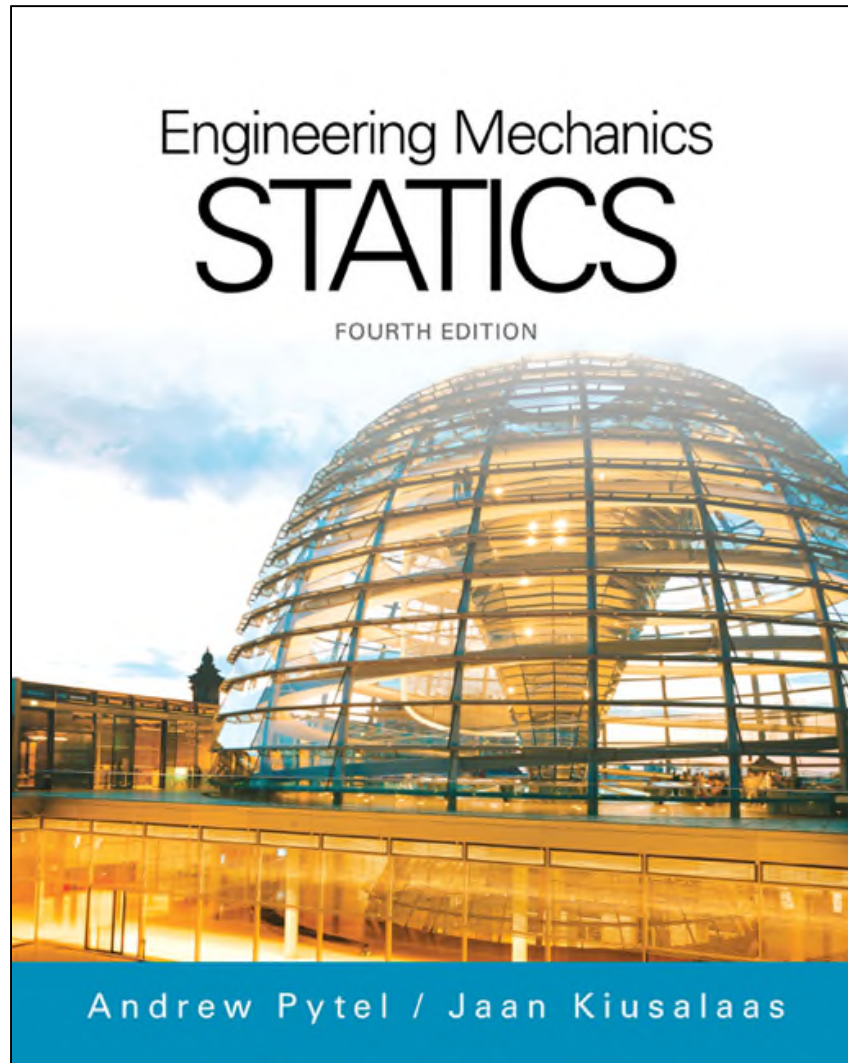

Chapter 2

Basic Operations with Force Systems

Introduction

- In this chapter we will study the effects of forces on particles and rigid bodies.
- We will learn to use vector algebra to reduce a system of force to a simpler, equivalent system.
- If all forces are concurrent (all forces intersect at the same point), we show the equivalent system is a single force.
- The reduction of a nonconcurrent force system requires two additional vector concepts: the moment of a force and the couple.

Equivalence of Vectors

- All vectors are quantities that have magnitude and direction, and combine according to the parallelogram law for addition.
- Two vectors that have the same magnitude and direction are equal.
- In mechanics, the term equivalence implies interchangeability; two vectors are equivalent if they are interchangeable without a change outcome.
- Equality does not result in equivalence.

Ex. A force applied to a certain body does not have the same effect on the body as an equal force acting at a different point.

Equivalence of Vectors

From the viewpoint of equivalence, vectors representing physical quantities are classified into the following three types:

- **Fixed vectors:** Equivalent vectors that have the same magnitude, direction, and point of application.
- **Sliding vectors:** Equivalent vectors that have the same magnitude, direction, and line of action.
- **Free vectors:** Equivalent vectors that have the same magnitude and direction.

Force

- Force is a mechanical interaction between bodies.
- Force can affect both the motion and the deformation of a body on which it acts.
- The area of contact force can be approximated to a point and is said to be concentrated at the point of contact.
- The line of action of a concentrated force is the line that passes through the point of application and is parallel to the force.

Force

- Force is a fixed vector because one of its characteristics is its point of application.
- For proof consider the following:

If forces are applied as shown in the figure below, the bar is under tension, and its deformation is an elongation.



Force

By interchanging the forces, the bar is placed in compression, resulting in shortening.

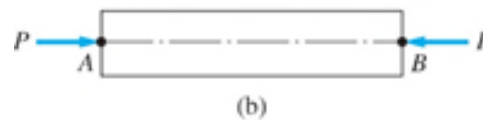

The loading in the figure below, where both forces are acting at point A , produces no deformation.

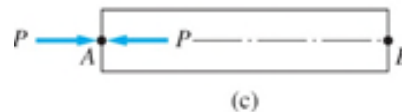

Force

- If the bar is rigid, there will be no observable difference in the behavior of the three previous bars, i.e. the external effects of the three loadings are identical.
- If we are interested in only the external effects, a force can be treated as a sliding vector and is summarized by the principles of transmissibility:

A force may be moved anywhere along its line of action without changing its external effects on a rigid body.

Reduction of Concurrent Force Systems

Method for replacing a system of concurrent forces with a single equivalent force:

Consider forces \mathbf{F}_1 , \mathbf{F}_2 , \mathbf{F}_3 , . . . Acting on the rigid body in the figure below

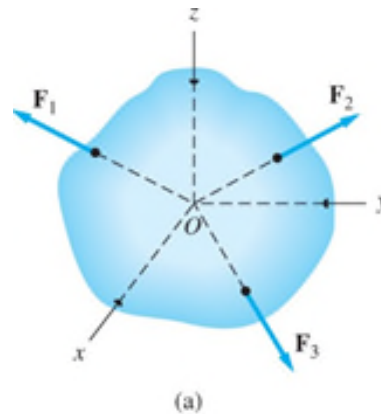

All the forces are concurrent at point O .

Reduction of Concurrent Force Systems

Those forces can be reduced to a single equivalent force by the following steps:

1. Move the forces along their lines of action to the point of concurrency O , as shown in the figure below.

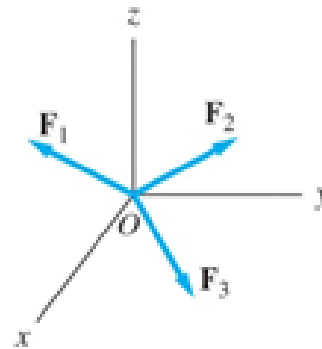

Reduction of Concurrent Force Systems

2. With the forces now at the common point O , compute their resultant \mathbf{R} from the vector sum

$$\mathbf{R} = \sum \mathbf{F} = \mathbf{F}_1 + \mathbf{F}_2 + \mathbf{F}_3 + \dots$$

This resultant, which is also equivalent to the original force system is shown below.

Note that the line of action \mathbf{R} must pass through the point of concurrency O in order for the equivalency to be valid.

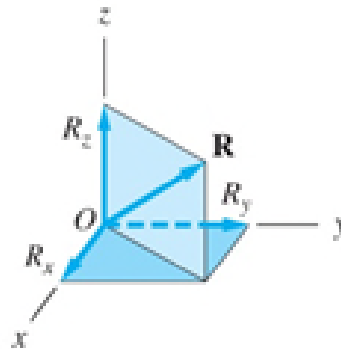

Moment of a Force about a Point

- A body tends to move in the direction of the force, and the magnitude of the force is proportional to its ability to translate the body.
- The tendency of a force to rotate a body is known as the moment of a force about a point.
- The rotational effect depends on the magnitude of the force and the distance between the point and the line of action of the force.

Moment of a Force about a Point

- Let \mathbf{F} be a force and O a point that is not on the line of action of \mathbf{F} , shown in the figure below.
- Let A be any point on the line of action of \mathbf{F} and define \mathbf{r} to be the vector from point O to point A .

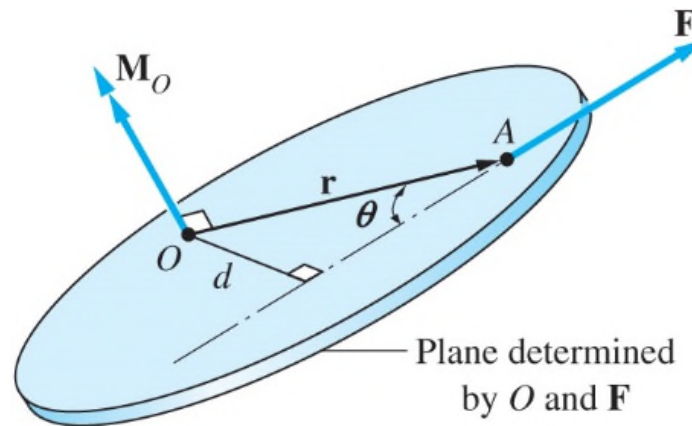

Figure 2.4

Moment of a Force about a Point

- The moment of the force about point O, called the moment center is defined as $\mathbf{M}_O = \mathbf{r} \times \mathbf{F}$
- The moment of \mathbf{F} about point O is a vector.
- From the properties of the cross product of two vectors, \mathbf{M}_O is perpendicular to both \mathbf{r} and \mathbf{F} .

Moment of a Force about a Point

Geometric Interpretation

- Scalar computation of the magnitude of the moment can be obtained from the geometric interpretation of $\mathbf{M}_o = \mathbf{r} \times \mathbf{F}$

Observe that the magnitude of \mathbf{M}_o is given by

$$M_o = |\mathbf{M}_o| = |\mathbf{r} \times \mathbf{F}| = rF \sin \theta$$

in which θ is the angle between \mathbf{r} and \mathbf{F} in the figure below.

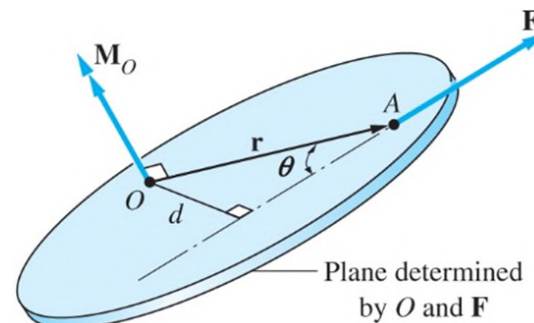

Figure 2.4

Moment of a Force about a Point

- From the previous figure we see that $r \sin \theta = d$ where d is the perpendicular distance from the moment center to the line of action of the force \mathbf{F} , called the moment arm of the force.
- The magnitude of \mathbf{M}_o is $M_o = Fd$
- Magnitude of \mathbf{M}_o depends only on the magnitude of the force and the perpendicular distance d , thus a force may be moved anywhere along its line of action without changing its moment about a point.
- In this application, a force may be treated as a sliding vector.

Moment of a Force about a Point

Principles of moments

- When determining the moment of a force about a point, it is convenient to use the principle of moments, i.e. the Varignon's theorem:

The moment of a force about a point is equal to the sum of the components about that point.

Moment of a Force about a Point

Proof of the Varignon's theorem

Consider three forces \mathbf{F}_1 , \mathbf{F}_2 , and \mathbf{F}_3 concurrent at point A , where \mathbf{r} is the vector from point O to point A as shown below.

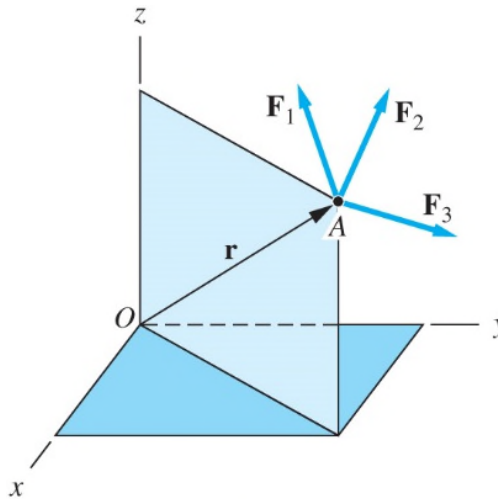

Figure 2.6

Moment of a Force about a Point

The sum of the moments about point O for the three forces is

$$\mathbf{M}_o = \sum(\mathbf{r} \times \mathbf{F}) = (\mathbf{r} \times F_1) + (\mathbf{r} \times F_2) + (\mathbf{r} \times F_3)$$

Using the properties of the cross product we can write

$$\mathbf{M}_o = \mathbf{r} \times (F_1 + F_2 + F_3) = \mathbf{r} \times \mathbf{R}$$

Where $\mathbf{R} = \mathbf{F}_1 + \mathbf{F}_2 + \mathbf{F}_3$ is the resultant force for the three original forces.

Moment of a Force about a Point

Vector and Scalar Methods

The vector method uses $\mathbf{M}_O = \mathbf{r} \times \mathbf{F}$, where \mathbf{r} is a vector from point O to any point on the line of action of \mathbf{F} .

The most efficient technique for using the vector method is the following:

1. Write \mathbf{F} in the vector form.
2. Choose an \mathbf{r} and write it in vector form.

Moment of a Force about a Point

3. Use the determinant form of $\mathbf{r} \times \mathbf{F}$ to evaluate \mathbf{M}_o :

$$\mathbf{M}_o = \mathbf{r} \times \mathbf{F} = \begin{vmatrix} \mathbf{i} & \mathbf{j} & \mathbf{k} \\ x & y & z \\ F_x & F_y & F_z \end{vmatrix}$$

where the second and third lines in the determinant are the determinant are the rectangular components of \mathbf{r} and \mathbf{F} .

Expansion of the determinant in the above equation yields:

$$\mathbf{M}_o = (yF_z - zF_y)\mathbf{i} + (zF_x - xF_z)\mathbf{j} + (xF_y - yF_x)\mathbf{k}$$

Moment of a Force about a Point

- In the scalar method, the magnitude of the moment of the force \mathbf{F} about the point O is found from $M_o = Fd$, with d as the moment arm of the force.
- For this method, the sense of the moment must be determined by inspection.
- The scalar method is convenient only when the moment arm d can be easily determined.

Moment of a Force about an Axis

- The moment of a force about an axis, called the moment axis, is defined in terms of the moment of the force about a point on the axis.

The figure below shows the force \mathbf{F} and its moment $\mathbf{M}_O = \mathbf{r} \times \mathbf{F}$ about point O , where O is any point on the axis AB

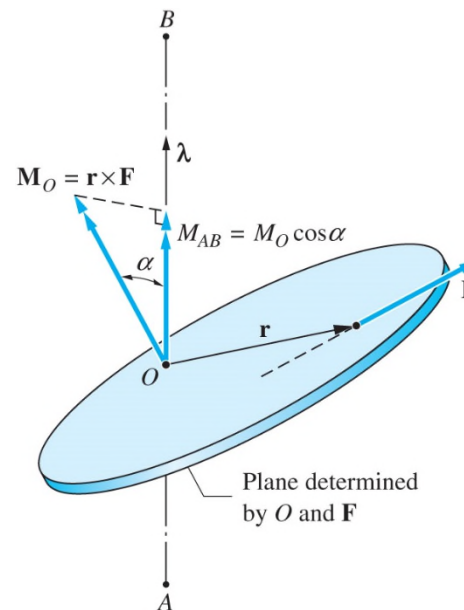

Figure 2.8

Moment of a Force about an Axis

We define the moment about an axis as:

The moment of \mathbf{F} about the axis AB is the orthogonal of \mathbf{M}_O along the axis AB, where O is any point on AB.

Letting λ be a unit vector directed from A toward B, this definition gives for the moment of \mathbf{F} about the axis AB:

$$M_{AB} = M_o \cos \alpha$$

where α is the angle between \mathbf{M}_O and λ shown in the previous figure.

$M_o \cos \alpha = \mathbf{M}_O \cdot \lambda$ can also be expressed in the form:

$$M_{AB} = \mathbf{M}_O \cdot \lambda = \mathbf{r} \times \mathbf{F} \cdot \lambda$$

Moment of a Force about an Axis

- Sometimes we express the moment of \mathbf{F} about the axis AB as a vector.
- This can be done by multiplying M_{AB} by the unit vector λ that specifies the direction of the moment axis, yielding

$$\mathbf{M}_{AB} = M_{AB} \lambda = (\mathbf{r} \times \mathbf{F} \cdot \lambda) \lambda$$

Moment of a Force about an Axis

For rectangular components of \mathbf{M}_O let M_x , M_y , and M_z be the moments of a force \mathbf{F} about O , where O is the origin of the xyz -coordinate system shown in the figure below.

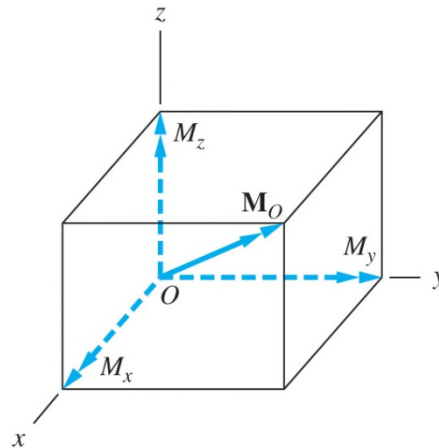

Figure 2.10

Moment of a Force about an Axis

The moments of \mathbf{F} about the three coordinate axes can be obtained from the equation:

$$M_{AB} = \mathbf{M}_0 \cdot \boldsymbol{\lambda} = \mathbf{r} \times \mathbf{F} \cdot \boldsymbol{\lambda}$$

The results are

$$M_x = \mathbf{M}_0 \cdot \mathbf{i} \quad M_y = \mathbf{M}_0 \cdot \mathbf{j} \quad M_z = \mathbf{M}_0 \cdot \mathbf{k}$$

Moment of a Force about an Axis

We can now draw the conclusion:

- The rectangular components of the moment of a force about the origin O are equal to the moments of the force about the coordinate axis.

i.e. $\mathbf{M}_o = M_x \mathbf{i} + M_y \mathbf{j} + M_z \mathbf{k}$

- M_x , M_y , and M_z shown in the previous figure are equal to the moments of the force about the coordinate axes.

Moment of a Force about an Axis

For the moment axis perpendicular to \mathbf{F} consider the case where the moment axis is perpendicular to the plane containing the force \mathbf{F} and the point O , as shown in the figure below.

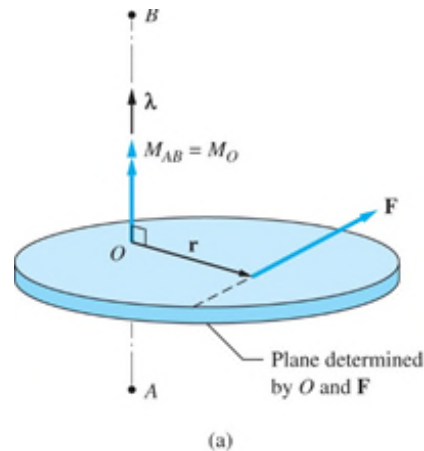

Because the directions of \mathbf{M}_O and \mathbf{M}_{AB} now coincide, λ in the equation $M_{AB} = \mathbf{M}_O \cdot \lambda = \mathbf{r} \times \mathbf{F} \cdot \lambda$ is in the direction \mathbf{M}_O .

Thus we now have: $M_O = M_{AB}$

Moment of a Force about an Axis

Geometric Interpretation

Examine the geometric interpretation of the equation $M_{AB} = \mathbf{r} \times \mathbf{F} \cdot \boldsymbol{\lambda}$

Suppose we are given in the arbitrary force \mathbf{F} and an arbitrary axis AB , as shown in the figure below.

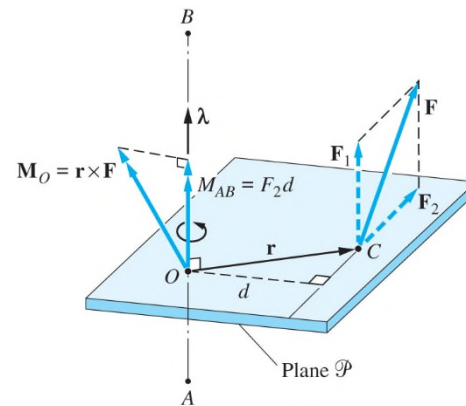

Figure 2.12

Moment of a Force about an Axis

We construct a plane P that is perpendicular to the AB axis and let O and C be the points where the axis and the line of action of the force intersects P .

The vector from O to C is denoted by \mathbf{r} , and λ is the unit vector along the axis AB .

We then resolve \mathbf{F} into two components: \mathbf{F}_1 and \mathbf{F}_2 , which are parallel and perpendicular to the axis AB .

Moment of a Force about an Axis

In terms of these components, the moment of \mathbf{F} about the axis AB is

$$\begin{aligned} M_{AB} &= \mathbf{r} \times \mathbf{F} \cdot \boldsymbol{\lambda} = \mathbf{r} \times (\mathbf{F}_1 + \mathbf{F}_2) \cdot \boldsymbol{\lambda} \\ &= \mathbf{r} \times \mathbf{F}_1 \cdot \boldsymbol{\lambda} + \mathbf{r} \times \mathbf{F}_2 \cdot \boldsymbol{\lambda} \end{aligned}$$

Because $\mathbf{r} \times \mathbf{F}_1$ is perpendicular to $\boldsymbol{\lambda}$, $\mathbf{r} \times \mathbf{F}_1 \cdot \boldsymbol{\lambda} = 0$, and we get:

$$M_{AB} = \mathbf{r} \times \mathbf{F}_2 \cdot \boldsymbol{\lambda}$$

Moment of a Force about an Axis

Substitution of $\mathbf{r} \times \mathbf{F}_2 \cdot \boldsymbol{\lambda} = F_2 d$ where d is the perpendicular distance from O to the line of action of \mathbf{F}_2 , yields:

$$M_{AB} = F_2 d$$

We see that the moment of \mathbf{F} about the axis AB equals the product of the component of \mathbf{F} that is perpendicular to AB and the perpendicular distance of this component from AB .

Moment of a Force about an Axis

The moment of a force about an axis possesses the following physical characteristics:

- A force that is parallel to the moment axis has no moment about that axis.
- If the line of action of a force intersects the moment axis, the force has no moment about that axis.
- The moment of a force is proportional to its component that is perpendicular to the moment axis, and the moment arm of that component.
- The sense of the moment is consistent with the direction in which the force would tend to rotate a body.

Moment of a Force about an Axis

Vector and Scalar Methods

- For the vector method the moment of \mathbf{F} about AB is obtained from the triple scalar product $M_{AB} = \mathbf{r} \times \mathbf{F} \cdot \boldsymbol{\lambda}$.
- \mathbf{r} is a vector drawn from any point on the moment axis AB to any point on the line of action of \mathbf{F} and $\boldsymbol{\lambda}$ represents a unit vector directed from A toward B.
- A convenient means of evaluating the scalar triple product is its determinant form

$$M_{AB} = \begin{vmatrix} x & y & z \\ F_x & F_y & F_z \\ \lambda_x & \lambda_y & \lambda_z \end{vmatrix}$$

where $x, y,$ and z are the rectangular components of \mathbf{r} .

Moment of a Force about an Axis

- For the scalar method the moment of \mathbf{F} about AB is obtained from the scalar expression $M_{AB} = F_2 d$.
- The sense of the moment must be determined by inspection.
- The method is convenient if AB is parallel to one of the coordinate axes.

Couples

- A force has two effects on a rigid body: translation due to the force itself and rotation due to the moment of the force.
- A couple is a purely rotational effect; it has a moment but no resultant force.
- Couples play an important role in the analysis of a force system.

Couples

Two parallel, noncollinear forces that are equal in magnitude and opposite in direction are known as a couple.

A typical couple is shown in the figure below.

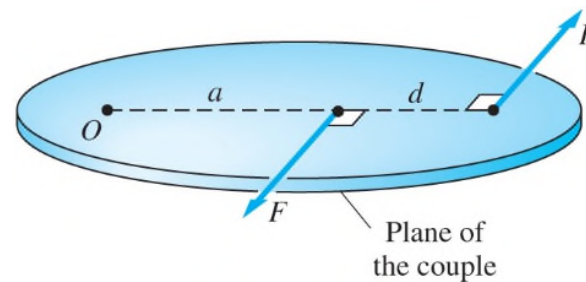

Figure 2.14

Couples

- The two forces of equal magnitude F are oppositely directed along the lines of action that are separated by the perpendicular distance d .
- The lines of action of the two forces determine a plane that we call the plane of the couple.
- The two forces that form a couple have some interesting properties, which will become apparent when we calculate their combined moment about a point.

Couples

Moment of a Couple about a Point

- The moment of a couple about a point is the sum of the moments of the two forces that form the couple.
- When calculating the moment of a couple about a point, either the scalar method or the vector method may be used.

Couples

For scalar calculation let us calculate the moment of the couple shown in the figure below about point O.

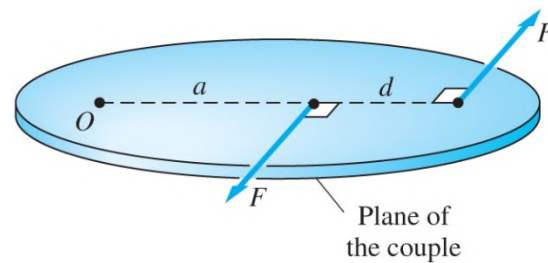

Figure 2.14

The sum of the moments about point O for the two forces is:

$$M_0 = F(a + d) - F(a) = Fd$$

Observe that the moment of the couple about point O is independent of the location of O, because the result is independent of the distance a.

Couples

When two forces from the couple are expressed as vectors, they can be denoted by \mathbf{F} and $-\mathbf{F}$, as shown in the figure below.

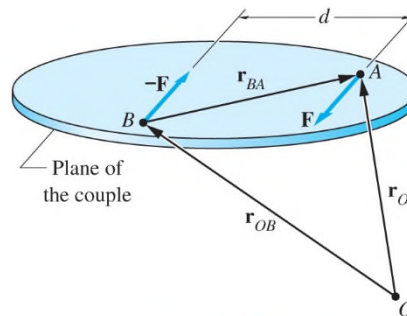

Figure 2.15

The points labeled in the figure are A, any point on the line of action of \mathbf{F} ; B, any point on the line of action of $-\mathbf{F}$; and O, an arbitrary point in space.

The vectors \mathbf{r}_{OA} and \mathbf{r}_{OB} are drawn from the point O to points A and B.

The vector \mathbf{r}_{BA} connects point B and A.

Couples

Using the cross product to evaluate the moment of the couple about point O, we get:

$$\mathbf{M}_o = \left[\mathbf{r}_{OA} \times \mathbf{F} \right] + \left[\mathbf{r}_{OB} \times (-\mathbf{F}) \right] = (\mathbf{r}_{OA} - \mathbf{r}_{OB}) \times \mathbf{F}$$

Couples

Since $\mathbf{r}_{OA} - \mathbf{r}_{OB} = \mathbf{r}_{BA}$, the moment of the couple about point O reduces to:

$$\mathbf{M}_O = \mathbf{r}_{BA} \times \mathbf{F}$$

this confirms that the moment of the couple about point O is independent of the location of O.

Although the choice of point O determines \mathbf{r}_{OA} and \mathbf{r}_{OB} , neither of these vectors appear in the both equation.

We conclude the moment of a couple is the same about every point.
i.e. The moment of a vector is a couple.

Couples

Equivalent couples

- Because a couple has no resultant force, its only effect on a rigid body is its moment.
- Because of this, two couples that have the same moment are equivalent.

Couples

The figure below illustrates the four operations that may be performed on a couple without change its moment.

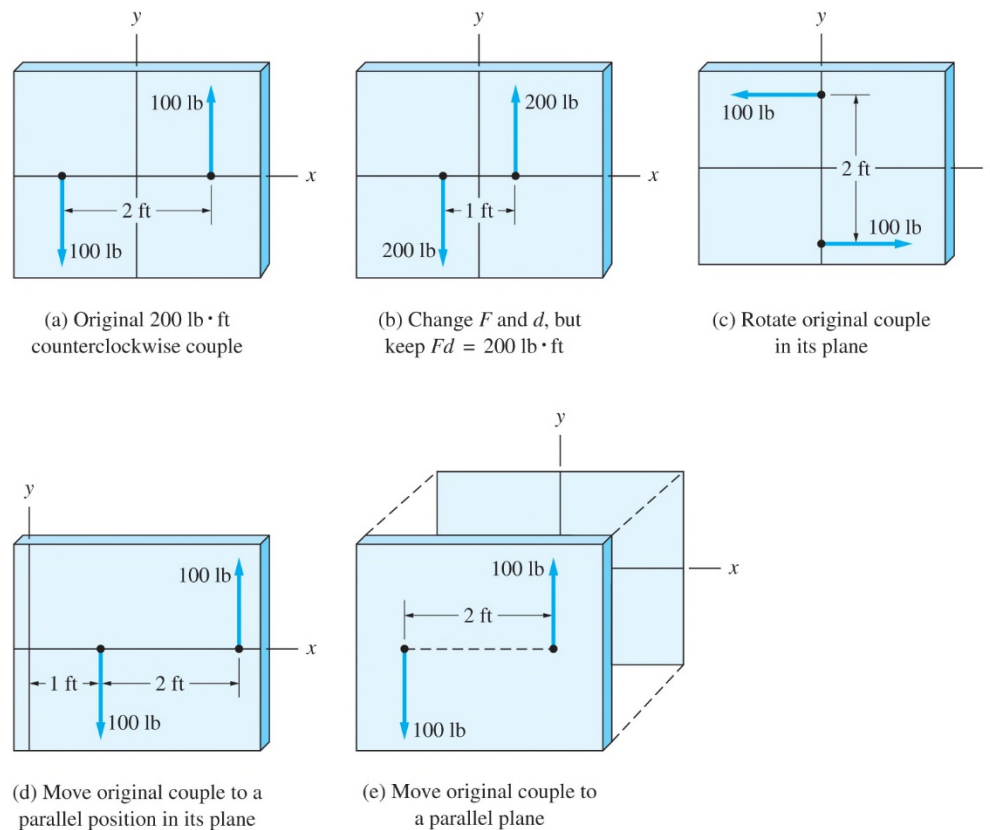
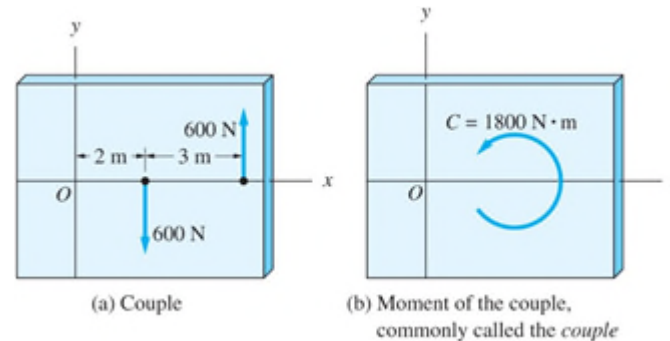

Figure 2.16

Couples

Notation and Terminology

Consider the couple and the moment shown in the figure below and has a magnitude of $C = 1800 \text{ N}\cdot\text{m}$ and is directed counterclockwise in the xy -plane.



Because the only rigid-body effect of a couple is its moment, the representations in the figures are equivalent.

Due to the equivalence we can replace a couple that acts on a rigid body by its moment without changing the external effect on the body.

Couples

The figure below shows the same couple as a vector, which we call the couple vector.

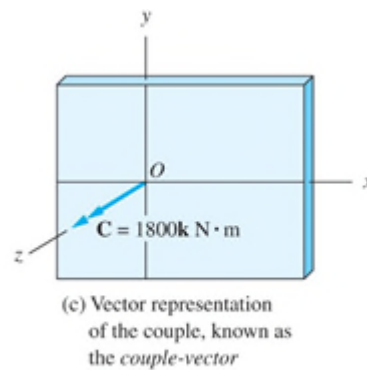

The couple-vector is perpendicular to the plane of the couple, and its direction is determined by the right-hand rule.

The choice of point O for the location of the couple vector was arbitrary.

Couples

The Addition and Resolution of Couples

- Because couples are vectors, they may be added by the usual rules of vector addition.
- Being free vectors, the requirement that the couples to be added must have a common point of application does not apply.
- Moments of forces can be added only if the moments are taken about the same point.

Couples

- The resolution of couples is no different than the resolution of moments of force.
- For example, the moment of a couple \mathbf{C} about an axis AB can be computed as

$$M_{AB} = \mathbf{C} \cdot \boldsymbol{\lambda}$$

where $\boldsymbol{\lambda}$ is the unit vector in the direction of the axis.

- As with moments of forces, M_{AB} is equal to the rectangular component of \mathbf{C} in the direction of \mathbf{AB} , and is a measure of the tendency of \mathbf{C} to rotate a body about the axis AB.

Changing the Line of Action of a Force

Referring to the figure below, consider the problem of moving the force of magnitude F from point B to point A .

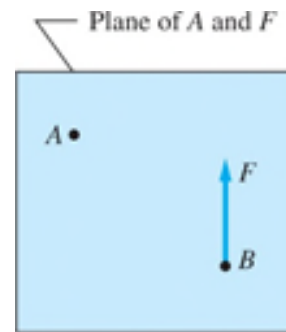

(a) Original force

We cannot simply move the force to A , because this would change its line of action, and alter the rotational effect of the force.

We can counteract the change by introducing a couple that restores the rotational effect to its original state.

Changing the Line of Action of a Force

The construction for determining this couple is illustrated below.

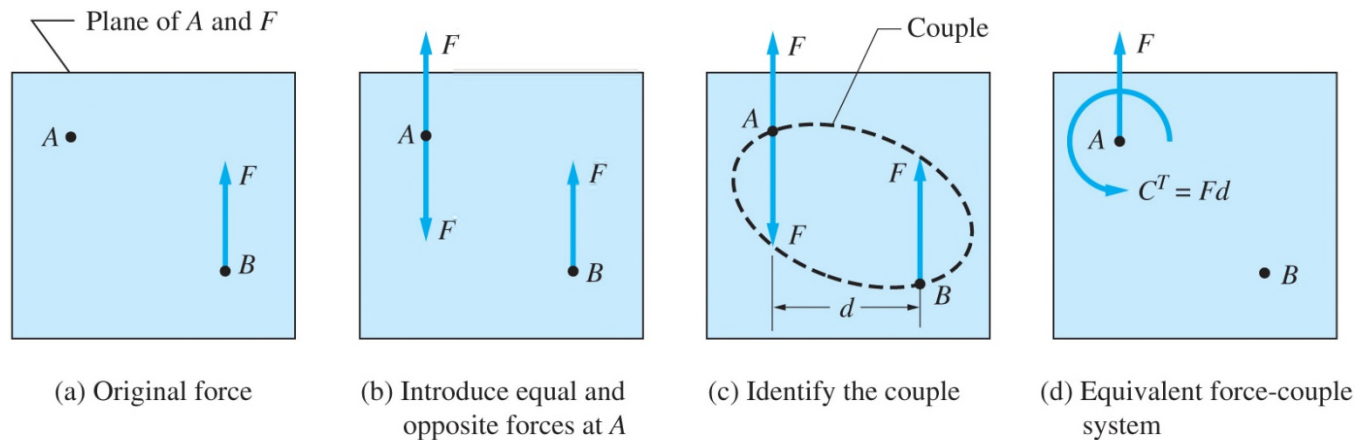

Figure P2.18

Changing the Line of Action of a Force

Our work consists of the following two steps:

1. Introduce two equal and opposite forces of magnitude F at point A, as shown in figure b.
 - These forces are parallel to the original force at B.
 - Because the forces at A have no net external effect on a rigid body, the force systems in figure a and b are equivalent.
2. Identify the two forces that form a couple, as has been done in figure c.
 - The magnitude of this couple $C^T = Fd$, where d is the distance between the line of action of the forces at A and B.
 - The third force and C^T thus constitute the force-couple system shown in figure d, which is equivalent to the original force shown in figure a.

Changing the Line of Action of a Force

- We refer to the couple C^T as the couple of transfer because it is the couple that must be introduced when a force is transferred from one line of action to another.
- From the previous figure we can conclude: The couple of transfer is equal to the moment of the original (acting at B) about the transfer point A.

Changing the Line of Action of a Force

- In vector terminology, the line of action of a force \mathbf{F} can be changed to a parallel line, provided that we introduce the couple of transfer

$$\mathbf{C}^T = \mathbf{r} \times \mathbf{F}$$

where \mathbf{r} is the vector drawn from the transfer point A to the point of application B of the original force in the figure shown.

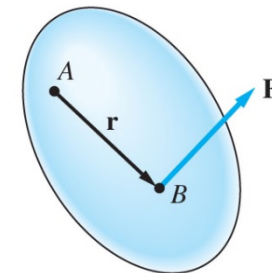

(a) Original force

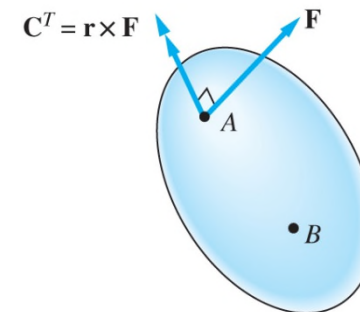

(b) Equivalent force-couple system

Figure 2.19

Changing the Line of Action of a Force

- According to the properties in the previous equation, the couple vector \mathbf{C}^T is perpendicular to \mathbf{F} .
- A force at a given point can always be replaced by a force at a different point and a couple-vector that is perpendicular to the force.
- The converse is also true: A force and a couple-vector that are mutually perpendicular can always be reduced to a single equivalent force by reversing the construction outline in the previous figure.