

MULTIPLE CHOICE. Choose the one alternative that best completes the statement or answers the question.

1) For this circuit, determine the load-line intersection with the two axis.

1) _____

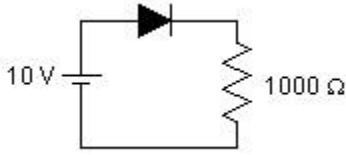

A) $V_D = 10\text{ V}$ and $I_D = 1\text{ mA}$

B) $V_D = 1\text{ V}$ and $I_D = 1\text{ mA}$

C) $V_D = 10\text{ V}$ and $I_D = 10\text{ mA}$

D) $V_D = 1\text{ V}$ and $I_D = 10\text{ mA}$

2) If one silicon diode and one germanium diode are connected in series, the voltage drop across the combination of the two diodes will be equal to _____.

2) _____

A) the forward drop equal to that of the silicon diode

B) the forward drop equal to that of the difference of the voltage drops across the two diodes

C) the forward drop equal to that of the sum of the voltage drops across the two diodes

D) the forward drop equal to that of the germanium diode

3) Name the logic gate that is formed by this circuit.

3) _____

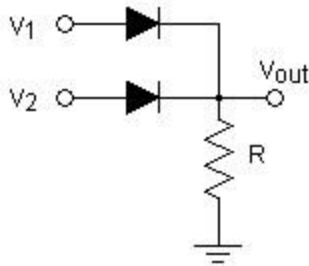

A) positive logic AND gate

B) negative logic AND gate

C) negative logic OR gate

D) positive logic OR gate

4) Name the logic gate that is formed by this circuit.

4) _____

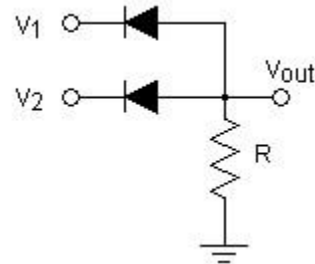

A) positive logic AND gate

B) negative logic OR gate

C) positive logic OR gate

D) negative logic AND gate

5) The current flows through the load resistor in this circuit during the _____.

5) _____

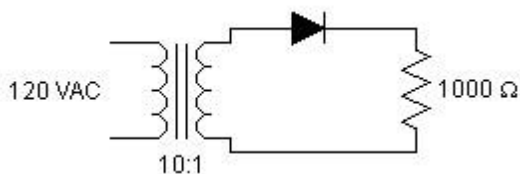

A) The diode will block all current and there will be no current flowing through the load.

B) positive half cycle of the input waveform

- C) negative half cycle of the input waveform
- D) entire input waveform

6) Calculate the peak current that will flow through this circuit, assuming an ideal diode. 6) _____

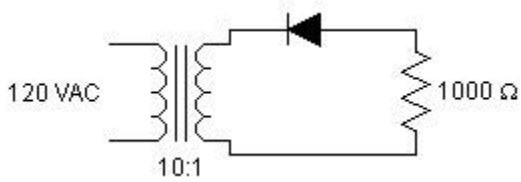

- A) 16.97 mA during the positive half cycle
- B) 16.97 mA during the negative half cycle
- C) 12 mA during the negative half cycle
- D) 12 mA during the positive half cycle

7) For this clipping circuit, what will be the maximum output voltage when the diode is conducting? 7) _____

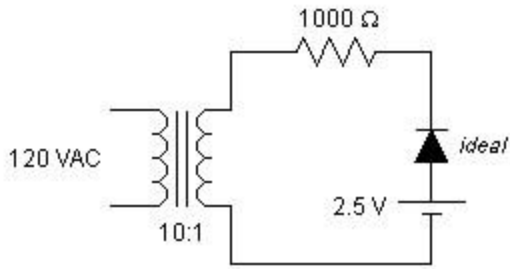

- A) + 19.47 Volts
- B) - 16.97 Volts
- C) + 2.5 Volts
- D) + 16.97 Volts

8) For this clipping circuit, what is the maximum output voltage when the diode is not conducting? 8) _____

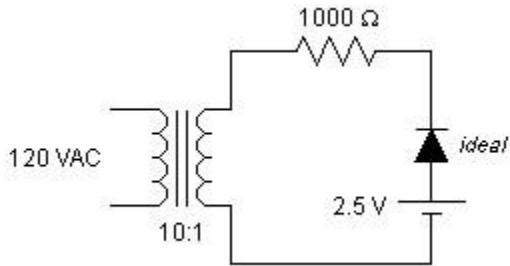

- A) + 16.97 V
- B) - 16.97 V
- C) + 19.47 V
- D) + 2.5 V

9) For this clipping circuit, what is the minimum output voltage when the diode is conducting? 9) _____

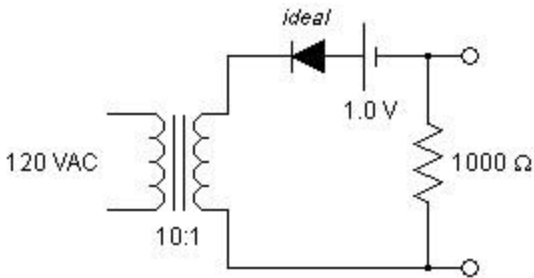

- A) - 17.97 V
- B) + 16.97 V
- C) - 16.97 V
- D) - 1.0 V

10) What is the minimum output voltage for this clipping circuit when the diode is not conducting?

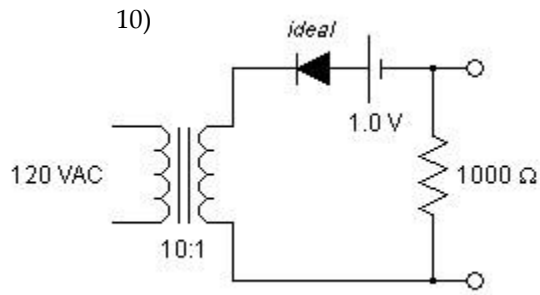

—
—

- A) - 17.97 V B) - 16.97 V C) 0 V D) + 16.97 V

11) What is the maximum output voltage for this clamping circuit?

11) _____

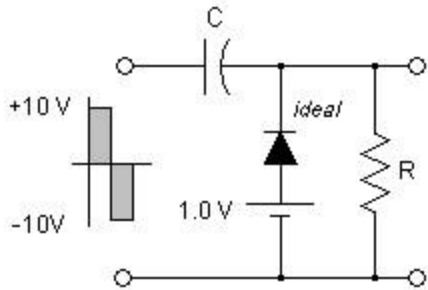

- A) + 21 Volts B) + 11 Volts C) - 11 Volts D) - 21 Volts

12) What is the minimum output voltage for this clamping circuit?

12) _____

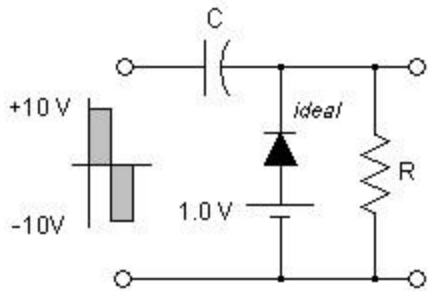

- A) + 1 V B) - 11 V C) - 1 V D) + 21 V

13) What are the minimum and maximum values of current flowing in the variable load resistor while the diode is operating in the Zener region? The zener voltage is 10 V.

13) _____

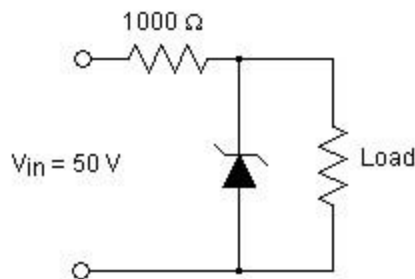

- A) 8 mA and 35 mA
 B) 12.5 mA and 40 mA
 C) Need to know the load resistance to determine the values.
 D) 8 mA and 40 mA

14) The point of intersection between the characteristic curve of the diode and the resistors loadline is known

as the 14) _____

- A) quiescent point
- B) Q-point
- C) point of operation
- D) All of the above

15) Given a series silicon diode circuit with the resistor $R = 2 \text{ k}\Omega$ ohms and an applied voltage of 10 V, what is I_{DQ} ? 15) _____

- A) 4.65 mA
- B) 0.5 mA
- C) 1.0 mA
- D) 10 mA

16) A series silicon diode circuit has a $2 \text{ k}\Omega$ resistor and a 10 V source. Determine V_{DQ} if I_{DQ} is 4.5 mA. 16) _____

- A) 0.7 V
- B) 2 V
- C) 1 V
- D) 11.5 V

17) For this series diode configuration, use the diode characteristic to estimate the value of V_R . 17) _____

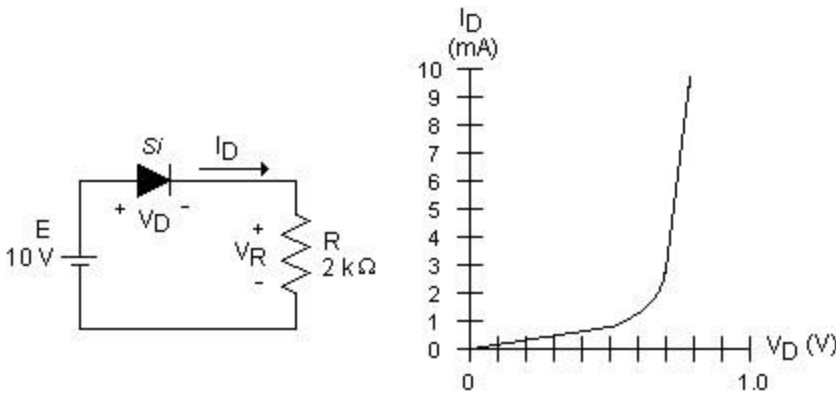

- A) 10 V
- B) 92 mV
- C) 0.92 V
- D) 9.2 V

18) Generally a silicon diode is in the _____ state if the current established by the applied voltage source is in the direction of the diode symbol's arrow and V_D is greater than or equal to 0.7 V. 18) _____

- A) saturated
- B) on
- C) off
- D) reverse-biased

19) Generally a germanium diode is in the _____ state when the current established by the applied voltage source is in the direction of the diode symbol's arrow and V_D is greater than or equal to 0.3 V. 19) _____

- A) on
- B) reverse-biased
- C) saturated
- D) off

20) The practical value of the current I_R in this circuit is _____. 20) _____

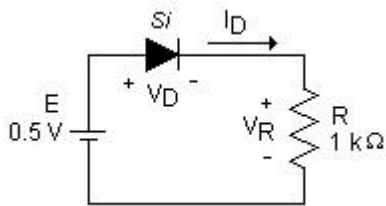

- A) 0 A
- B) 0.5 mA
- C) 5 mA
- D) 0.5 A

21) The resistor voltage and resistor current in this circuit are _____.

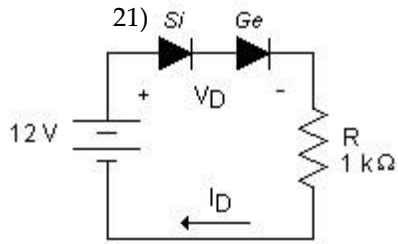

- A) 10 V, 5 mA B) 2 V, 11 mA C) 11 V, 2 mA D) 11 V, 11 mA

22) What is the value of the voltage dropped across forward-biased silicon diodes that are connected in parallel with each other? 22) _____

- A) 11.3 V B) 1.4 V C) 0.35 V D) 0.7 V

23) The value of V_D in this circuit is _____. 23) _____

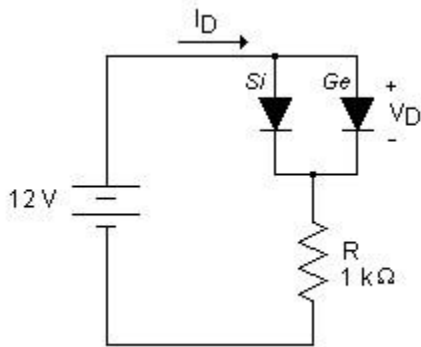

- A) 11.3 V B) 0.3 V C) 0.7 V D) 10.6 V

24) When the diode in a half-wave rectifier points toward the load, the output from the rectifier is _____. 24) _____

- A) either positive or negative, depending on the polarity of the transformer secondary voltage
 B) positive
 C) negative
 D) full-wave

25) A half-wave rectifier with the diode arrow pointing away from the load has a DC output voltage of _____ for an AC input voltage of 20 V maximum. 25) _____

- A) -6.14 V B) 12.49 V C) 19.3 V D) -13.65 V

26) Why are bridge rectifiers preferred over full-wave center-tapped rectifiers? 26) _____

- A) They provide higher dc output voltages.
 B) They require a lower PIV rating.
 C) They do not require the use of a center-tapped transformer.
 D) All the above

27) A bridge rectifier has values of $V_m = 177$ V, turns ratio = 5 : 1, and $R_L = 500 \Omega$. What is the dc output voltage? 27) _____

- A) 3.75 V B) 6.88 V C) 21.62 V D) 9.91 V

28) A positive full-wave center-tapped rectifier has a secondary voltage of 20 V_m . The peak load voltage for the circuit is _____ if the diode drop is included. 28) _____

- A) 10 V_P B) 19.3 V_P C) 20 V_P D) 9.3 V_P

29) A full-wave center-tapped rectifier has a secondary maximum voltage of $20 V_m$ and a $4.7 k\Omega$ load resistance. What is the dc load current for the circuit? 29) _____
 A) 2.61 mA B) 629.8 mA C) 1.26 mA D) 1.4 mA

30) Which of the following circuits is used to eliminate a portion of a signal? 30) _____
 A) Voltage multiplier B) Clipper
 C) Voltage divider D) Damper

31) The two general categories of clippers are _____. 31) _____
 A) half-wave and full-wave B) series and parallel
 C) dc restorer and dc eliminator D) regenerator and eliminator

32) The circuit shown here is a _____. 32) _____

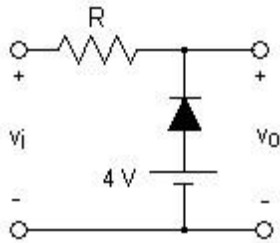

A) series clamper B) shunt clamper C) shunt clipper D) series clipper

33) A(n) _____ is commonly used to provide transient protection. 33) _____
 A) eliminator B) clipper C) clamper D) multiplier

34) Which of the following circuits is used to change the dc reference of a signal without changing the shape of the signal? 34) _____
 A) a clamper B) a voltage multiplier
 C) a voltage divider D) a clipper

35) A clamper must have a(n) _____ that is large enough to maintain the capacitor's charge during diode conduction. 35) _____
 A) dc restorer B) applied voltage
 C) diode voltage D) RC time constant

36) This circuit uses a _____. 36) _____

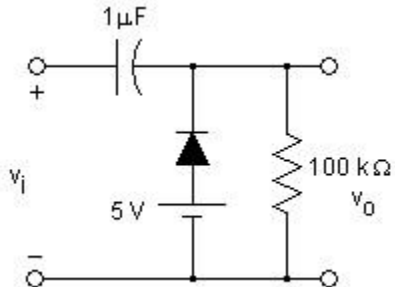

A) negative clipper B) positive clamper
 C) positive clipper D) negative clamper

37) Assuming this circuit uses a silicon diode, the output voltage is clamped to _____.

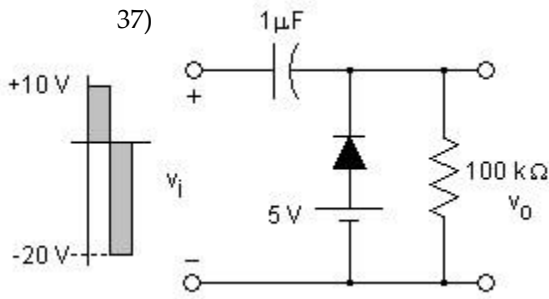

- A) 4.3 V B) 5.3 V C) 5.7 V D) 10.7 V

38) The biased clamper has a dc reference voltage that is _____. 38) _____

- A) approximately equal to zero volts
 B) dependent on the peak-to-peak value of the ac input
 C) equal to the dc average of the circuits output signal
 D) approximately equal to the dc voltage that is applied to the diode

39) Given that a 1000 Hz signal is applied to a clamper with a resistor value of 10 kΩ. What is the minimum value of capacitor needed to maintain safe clamping action? 39) _____

- A) 0.25 pF B) 250 pF C) 5 pF D) 10 pF

40) When the output signal to a clamper circuit is clamped to zero, the total swing of the output is equal to _____. 40) _____

- A) the total diode voltage drop B) half the total voltage drop
 C) half the total input voltage swing D) the total input voltage swing

41) The Zener diode is on if the applied voltage, V , is _____. 41) _____

- A) $V < V_Z / 2$ B) $V \geq V_Z$ C) $V > 2V_Z$ D) $V < V_Z$

42) When in its "on" state, the voltage across an ideal Zener diode, V_Z _____. 42) _____

- A) increases sharply with a decrease in applied voltage
 B) gets smaller with an increase in applied voltage
 C) gets larger with an increase in applied voltage
 D) None of these

43) The Zener diode must be operated such that _____. 43) _____

- A) the applied voltage is greater than V_Z B) $I_Z \times V_Z = P_Z$
 C) P_Z is less than the specified P_{Zmax} D) All of these

44) The most frequent application for a _____ is in regulator networks and as a reference voltage. 44) _____

- A) Zener diode B) half-wave rectifier
 C) ideal diode D) full-wave rectifier

45) A typical Zener diode regulator circuit uses a _____. 45) _____

- A) resistor in parallel with the load
 B) Zener diode in parallel with the series resistor
 C) dropping resistor in series with the load
 D) Zener diode in series with the load

46) When the Zener regulator is used to stabilize the output voltage, given a fixed input voltage and a variable load, the output voltage is _____.

e load 46)
resistanc
e, a load
resistanc
e that is
too small
results in

—
—

- A) V_L being greater than V_Z B) V_Z being equal to V_{in}
C) V_L being equal to V_Z D) V_L being less than V_Z

- 47) When a Zener diode circuit is used to stabilize the output voltage given a fixed load resistor and a variable input voltage, the input voltage must be _____. 47) _____
A) small enough to turn off the Zener diode B) large enough to turn on the Zener diode
C) small enough to turn on the Zener diode D) large enough to turn off the Zener diode
- 48) Two Zener diodes connected _____ can be used as an ac regulator. 48) _____
A) in series with the load B) in series with the input voltage
C) in parallel with each other D) back-to-back
- 49) A Zener diode is designed to operate in the _____ region of its characteristic curve. 49) _____
A) reverse breakdown B) reverse bias
C) zero voltage D) forward operating
- 50) When analyzing a diode circuit with both a dc and ac source _____. 50) _____
A) first determine the bulk resistance of the diode
B) only the dc source is considered
C) use superposition
D) Thevenize the circuit

- 1) C
- 2) C
- 3) D
- 4) C
- 5) B
- 6) B
- 7) C
- 8) A
- 9) D
- 10) C
- 11) A
- 12) C
- 13) D
- 14) D
- 15) A
- 16) C
- 17) D
- 18) B
- 19) A
- 20) A
- 21) D
- 22) D
- 23) B
- 24) B
- 25) A
- 26) D
- 27) C
- 28) D
- 29) C
- 30) B
- 31) B
- 32) C
- 33) B
- 34) A
- 35) D
- 36) D
- 37) A
- 38) D
- 39) B
- 40) D
- 41) B
- 42) D
- 43) D
- 44) A
- 45) C
- 46) D
- 47) B
- 48) D
- 49) A
- 50) C