

MULTIPLE CHOICE. Choose the one alternative that best completes the statement or answers the question.

Find the average velocity of the function over the given interval.

1) $y = x^2 + 3x$, $[1, 8]$ 1) _____
 A) $\frac{88}{7}$ B) $\frac{21}{2}$ C) 11 D) 12

2) $y = 9x^3 + 5x^2 - 8$, $[-2, 8]$ 2) _____
 A) 492 B) $\frac{1245}{2}$ C) 615 D) 498

3) $y = \sqrt{2x}$, $[2, 8]$ 3) _____
 A) 2 B) $\frac{1}{3}$ C) 7 D) $-\frac{3}{10}$

4) $y = \frac{3}{x-2}$, $[4, 7]$ 4) _____
 A) $-\frac{3}{10}$ B) 7 C) $\frac{1}{3}$ D) 2

5) $y = 4x^2$, $\left[0, \frac{7}{4}\right]$ 5) _____
 A) $\frac{1}{3}$ B) 2 C) $-\frac{3}{10}$ D) 7

6) $y = -3x^2 - x$, $[5, 6]$ 6) _____
 A) $\frac{1}{2}$ B) -2 C) $-\frac{1}{6}$ D) -34

7) $h(t) = \sin(3t)$, $\left[0, \frac{\pi}{6}\right]$ 7) _____
 A) $-\frac{6}{\pi}$ B) $\frac{\pi}{6}$ C) $\frac{3}{\pi}$ D) $\frac{6}{\pi}$

8) $g(t) = 4 + \tan t$, $\left[-\frac{\pi}{4}, \frac{\pi}{4}\right]$ 8) _____
 A) $-\frac{3}{2}$ B) $-\frac{4}{\pi}$ C) $\frac{4}{\pi}$ D) 0

Use the table to find the instantaneous velocity of y at the specified value of x .

9) $x = 1$.

9) _____

x	y
0	0
0.2	0.02
0.4	0.08
0.6	0.18
0.8	0.32
1.0	0.5
1.2	0.72
1.4	0.98

A) 0.5

B) 2

C) 1

D) 1.5

10) $x = 1$.

10) _____

x	y
0	0
0.2	0.01
0.4	0.04
0.6	0.09
0.8	0.16
1.0	0.25
1.2	0.36
1.4	0.49

A) 1.5

B) 2

C) 1

D) 0.5

11) $x = 1$.

11) _____

x	y
0	0
0.2	0.12
0.4	0.48
0.6	1.08
0.8	1.92
1.0	3
1.2	4.32
1.4	5.88

A) 8

B) 6

C) 2

D) 4

12) $x = 2$.

12) _____

x	y
0	10
0.5	38
1.0	58
1.5	70
2.0	74
2.5	70
3.0	58
3.5	38
4.0	10

A) 0

B) 4

C) 8

D) -8

13) $x = 1$.

13) _____

x	y
0.900	-0.05263
0.990	-0.00503
0.999	-0.0005
1.000	0.0000
1.001	0.0005
1.010	0.00498
1.100	0.04762

A) 0.5

B) -0.5

C) 0

D) 1

Find the slope of the curve for the given value of x.

14) $y = x^2 + 5x, x = 4$

14) _____

A) slope is $\frac{1}{20}$

B) slope is -39

C) slope is $-\frac{4}{25}$

D) slope is 13

15) $y = x^2 + 11x - 15, x = 1$

15) _____

A) slope is $\frac{1}{20}$

B) slope is -39

C) slope is $-\frac{4}{25}$

D) slope is 13

16) $y = x^3 - 5x, x = 1$

16) _____

A) slope is -3

B) slope is 1

C) slope is -2

D) slope is 3

17) $y = x^3 - 2x^2 + 4, x = 3$

17) _____

A) slope is 1

B) slope is -15

C) slope is 15

D) slope is 0

18) $y = 2 - x^3, x = -1$

18) _____

A) slope is 0

B) slope is 3

C) slope is -3

D) slope is -1

Solve the problem.

19) Given $\lim_{x \rightarrow 0^-} f(x) = L_L$, $\lim_{x \rightarrow 0^+} f(x) = L_R$, and $L_L \neq L_R$, which of the following statements is true? 19) _____

- I. $\lim_{x \rightarrow 0} f(x) = L_L$
- II. $\lim_{x \rightarrow 0} f(x) = L_R$
- III. $\lim_{x \rightarrow 0} f(x)$ does not exist.

A) none B) I C) III D) II

20) Given $\lim_{x \rightarrow 0^-} f(x) = L_L$, $\lim_{x \rightarrow 0^+} f(x) = L_R$, and $L_L = L_R$, which of the following statements is false? 20) _____

- I. $\lim_{x \rightarrow 0} f(x) = L_L$
- II. $\lim_{x \rightarrow 0} f(x) = L_R$
- III. $\lim_{x \rightarrow 0} f(x)$ does not exist.

A) I B) III C) II D) none

21) If $\lim_{x \rightarrow 0} f(x) = L$, which of the following expressions are true? 21) _____

- I. $\lim_{x \rightarrow 0^-} f(x)$ does not exist.
- II. $\lim_{x \rightarrow 0^+} f(x)$ does not exist.
- III. $\lim_{x \rightarrow 0^-} f(x) = L$
- IV. $\lim_{x \rightarrow 0^+} f(x) = L$

A) I and II only B) I and IV only C) III and IV only D) II and III only

22) What conditions, when present, are sufficient to conclude that a function $f(x)$ has a limit as x approaches some value of a ? 22) _____

- A) Either the limit of $f(x)$ as $x \rightarrow a$ from the left exists or the limit of $f(x)$ as $x \rightarrow a$ from the right exists
- B) $f(a)$ exists, the limit of $f(x)$ as $x \rightarrow a$ from the left exists, and the limit of $f(x)$ as $x \rightarrow a$ from the right exists.
- C) The limit of $f(x)$ as $x \rightarrow a$ from the left exists, the limit of $f(x)$ as $x \rightarrow a$ from the right exists, and at least one of these limits is the same as $f(a)$.
- D) The limit of $f(x)$ as $x \rightarrow a$ from the left exists, the limit of $f(x)$ as $x \rightarrow a$ from the right exists, and these two limits are the same.

Use the graph to evaluate the limit.

23) $\lim_{x \rightarrow -1} f(x)$

23) _____

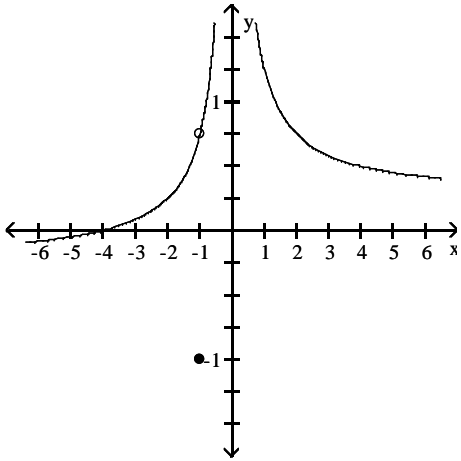

A) $\frac{3}{4}$

B) ∞

C) -1

D) $-\frac{3}{4}$

24) $\lim_{x \rightarrow 0} f(x)$

24) _____

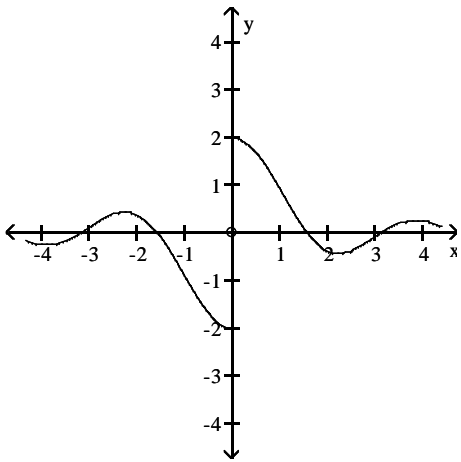

A) -2

B) 2

C) 0

D) does not exist

25) $\lim_{x \rightarrow 0} f(x)$

25) _____

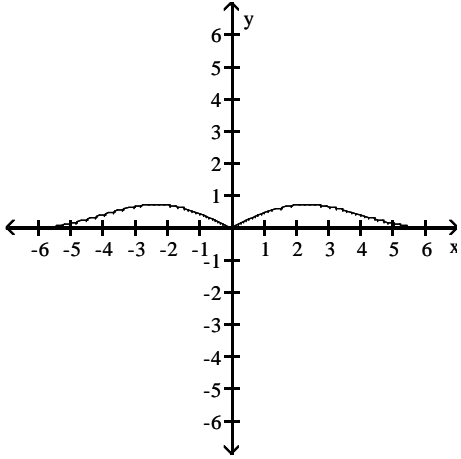

A) 0

B) does not exist

C) -1

D) 1

26) $\lim_{x \rightarrow 0} f(x)$

26) _____

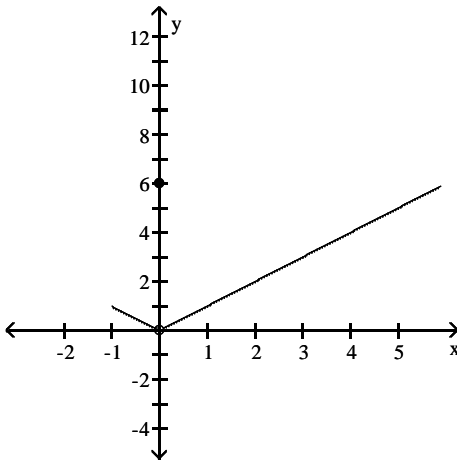

A) -1

B) 6

C) 0

D) does not exist

27) $\lim_{x \rightarrow 0} f(x)$

27) _____

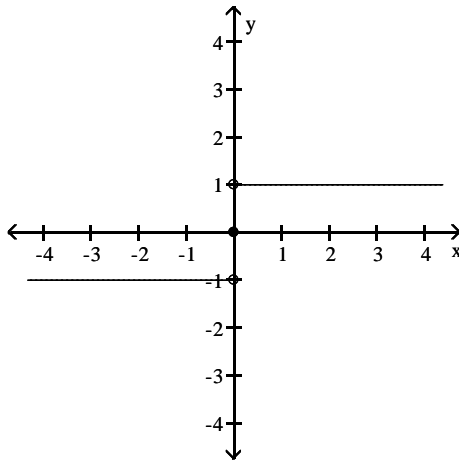

A) -1

B) does not exist

C) 1

D) ∞

28) $\lim_{x \rightarrow 0} f(x)$

28) _____

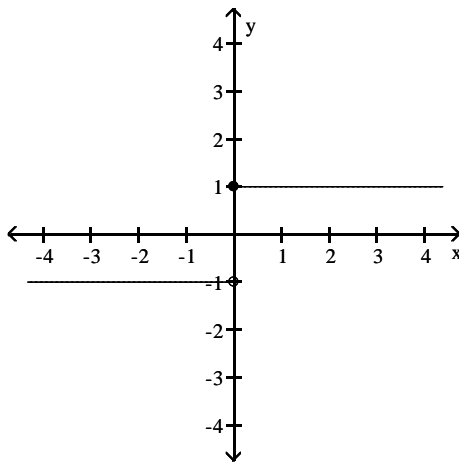

A) ∞

B) does not exist

C) -1

D) 1

29) $\lim_{x \rightarrow 0} f(x)$

29) _____

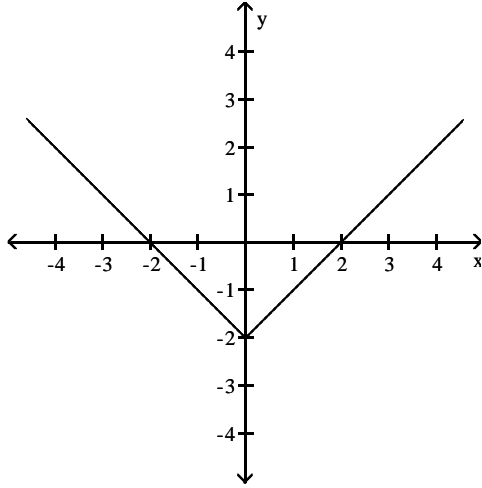

- A) 2 B) does not exist C) 0 D) -2

30) $\lim_{x \rightarrow 0} f(x)$

30) _____

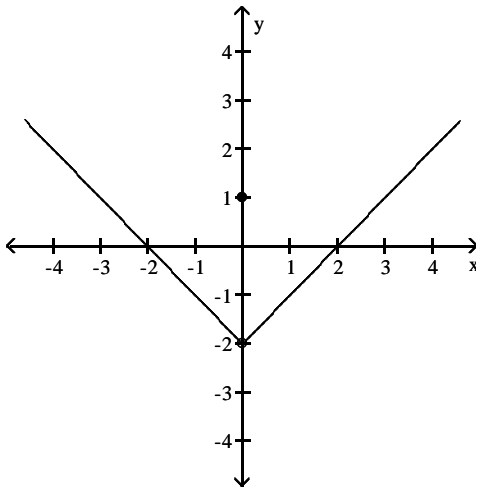

- A) does not exist B) 0 C) -2 D) 1

31) $\lim_{x \rightarrow 0} f(x)$

31) _____

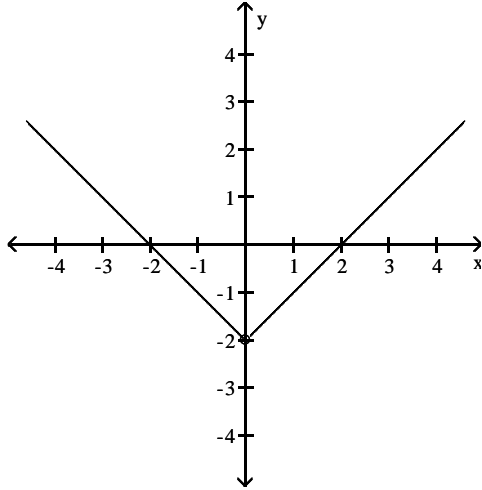

A) 2

B) -1

C) does not exist

D) -2

32) Find $\lim_{x \rightarrow (-1)^-} f(x)$ and $\lim_{x \rightarrow (-1)^+} f(x)$

32) _____

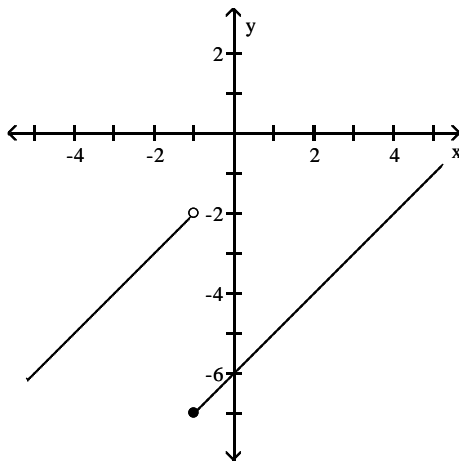

A) -7; -5

B) -7; -2

C) -5; -2

D) -2; -7

Use the table of values of f to estimate the limit.

33) Let $f(x) = x^2 + 8x - 2$, find $\lim_{x \rightarrow 2} f(x)$.

33) _____

x	1.9	1.99	1.999	2.001	2.01	2.1
$f(x)$						

A)

x	1.9	1.99	1.999	2.001	2.01	2.1
$f(x)$	5.043	5.364	5.396	5.404	5.436	5.763

; limit = ∞

B)

x	1.9	1.99	1.999	2.001	2.01	2.1
$f(x)$	5.043	5.364	5.396	5.404	5.436	5.763

; limit = 5.40

C)

x	1.9	1.99	1.999	2.001	2.01	2.1
$f(x)$	16.810	17.880	17.988	18.012	18.120	19.210

; limit = 18.0

D)

x	1.9	1.99	1.999	2.001	2.01	2.1
$f(x)$	16.692	17.592	17.689	17.710	17.808	18.789

; limit = 17.70

34) Let $f(x) = \frac{x-4}{\sqrt{x}-2}$, find $\lim_{x \rightarrow 4} f(x)$.

34) _____

x	3.9	3.99	3.999	4.001	4.01	4.1
$f(x)$						

A)

x	3.9	3.99	3.999	4.001	4.01	4.1
$f(x)$	5.07736	5.09775	5.09978	5.10022	5.10225	5.12236

; limit = 5.10

B)

x	3.9	3.99	3.999	4.001	4.01	4.1
$f(x)$	3.97484	3.99750	3.99975	4.00025	4.00250	4.02485

; limit = 4.0

C)

x	3.9	3.99	3.999	4.001	4.01	4.1
$f(x)$	1.19245	1.19925	1.19993	1.20007	1.20075	1.20745

; limit = 1.20

D)

x	3.9	3.99	3.999	4.001	4.01	4.1
$f(x)$	1.19245	1.19925	1.19993	1.20007	1.20075	1.20745

; limit = ∞

35) Let $f(x) = x^2 - 5$, find $\lim_{x \rightarrow 0} f(x)$.

35) _____

x	-0.1	-0.01	-0.001	0.001	0.01	0.1
f(x)						

A)

x	-0.1	-0.01	-0.001	0.001	0.01	0.1
f(x)	-4.9900	-4.9999	-5.0000	-5.0000	-4.9999	-4.9900

; limit = -5.0

B)

x	-0.1	-0.01	-0.001	0.001	0.01	0.1
f(x)	-2.9910	-2.9999	-3.0000	-3.0000	-2.9999	-2.9910

; limit = -3.0

C)

x	-0.1	-0.01	-0.001	0.001	0.01	0.1
f(x)	-1.4970	-1.4999	-1.5000	-1.5000	-1.4999	-1.4970

; limit = -15.0

D)

x	-0.1	-0.01	-0.001	0.001	0.01	0.1
f(x)	-1.4970	-1.4999	-1.5000	-1.5000	-1.4999	-1.4970

; limit = ∞

36) Let $f(x) = \frac{x+2}{x^2+5x+6}$, find $\lim_{x \rightarrow -2} f(x)$.

36) _____

x	-2.1	-2.01	-2.001	-1.999	-1.99	-1.9
f(x)						

A)

x	-2.1	-2.01	-2.001	-1.999	-1.99	-1.9
f(x)	1.0111	0.9101	0.9010	0.8990	0.8901	0.8091

; limit = 0.9

B)

x	-2.1	-2.01	-2.001	-1.999	-1.99	-1.9
f(x)	-1.1111	-1.0101	-1.0010	-0.9990	-0.9901	-0.9091

; limit = -1

C)

x	-2.1	-2.01	-2.001	-1.999	-1.99	-1.9
f(x)	1.1111	1.0101	1.0010	0.9990	0.9901	0.9091

; limit = 1

D)

x	-2.1	-2.01	-2.001	-1.999	-1.99	-1.9
f(x)	1.2111	1.1101	1.1010	1.0990	1.0901	1.0091

; limit = 1.1

37) Let $f(x) = \frac{x^2 + 3x + 2}{x^2 - 2x - 3}$, find $\lim_{x \rightarrow -1} f(x)$.

37) _____

x	-1.1	-1.01	-1.001	-0.999	-0.99	-0.9
f(x)						

A)

x	-1.1	-1.01	-1.001	-0.999	-0.99	-0.9
f(x)	-1.3810	-1.4876	-1.4988	-1.5013	-1.5126	-1.6316

; limit = -1.5

B)

x	-1.1	-1.01	-1.001	-0.999	-0.99	-0.9
f(x)	-0.1195	-0.1469	-0.1497	-0.1503	-0.1531	-0.1821

; limit = -0.15

C)

x	-1.1	-1.01	-1.001	-0.999	-0.99	-0.9
f(x)	-0.2195	-0.2469	-0.2497	-0.2503	-0.2531	-0.2821

; limit = -0.25

D)

x	-1.1	-1.01	-1.001	-0.999	-0.99	-0.9
f(x)	-0.3195	-0.3469	-0.3497	-0.3503	-0.3531	-0.3821

; limit = -0.35

38) Let $f(x) = \frac{\sin(8x)}{x}$, find $\lim_{x \rightarrow 0} f(x)$.

38) _____

x	-0.1	-0.01	-0.001	0.001	0.01	0.1
f(x)		7.9914694			7.9914694	

- A) limit = 7.5
C) limit = 0

- B) limit does not exist
D) limit = 8

39) Let $f(\theta) = \frac{\cos(6\theta)}{\theta}$, find $\lim_{\theta \rightarrow 0} f(\theta)$.

39) _____

x	-0.1	-0.01	-0.001	0.001	0.01	0.1
f(θ)	-8.2533561					8.2533561

- A) limit = 0
C) limit = 8.2533561

- B) limit does not exist
D) limit = 6

SHORT ANSWER. Write the word or phrase that best completes each statement or answers the question.

Provide an appropriate response.

40) It can be shown that the inequalities $1 - \frac{x^2}{6} < \frac{x \sin(x)}{2 - 2 \cos(x)} < 1$ hold for all values of x close to zero. What, if anything, does this tell you about $\frac{x \sin(x)}{2 - 2 \cos(x)}$? Explain. 40) _____

MULTIPLE CHOICE. Choose the one alternative that best completes the statement or answers the question.

41) Write the formal notation for the principle "the limit of a quotient is the quotient of the limits" and include a statement of any restrictions on the principle. 41) _____

A) $\lim_{x \rightarrow a} \frac{g(x)}{f(x)} = \frac{g(a)}{f(a)}$, provided that $f(a) \neq 0$.

B) If $\lim_{x \rightarrow a} g(x) = M$ and $\lim_{x \rightarrow a} f(x) = L$, then $\lim_{x \rightarrow a} \frac{g(x)}{f(x)} = \frac{\lim_{x \rightarrow a} g(x)}{\lim_{x \rightarrow a} f(x)} = \frac{M}{L}$, provided that $f(a) \neq 0$.

C) If $\lim_{x \rightarrow a} g(x) = M$ and $\lim_{x \rightarrow a} f(x) = L$, then $\lim_{x \rightarrow a} \frac{g(x)}{f(x)} = \frac{\lim_{x \rightarrow a} g(x)}{\lim_{x \rightarrow a} f(x)} = \frac{M}{L}$, provided that $L \neq 0$.

D) $\lim_{x \rightarrow a} \frac{g(x)}{f(x)} = \frac{g(a)}{f(a)}$.

42) Provide a short sentence that summarizes the general limit principle given by the formal notation $\lim_{x \rightarrow a} [f(x) \pm g(x)] = \lim_{x \rightarrow a} f(x) \pm \lim_{x \rightarrow a} g(x) = L \pm M$, given that $\lim_{x \rightarrow a} f(x) = L$ and $\lim_{x \rightarrow a} g(x) = M$. 42) _____

A) The limit of a sum or a difference is the sum or the difference of the limits.

B) The limit of a sum or a difference is the sum or the difference of the functions.

C) The sum or the difference of two functions is the sum of two limits.

D) The sum or the difference of two functions is continuous.

43) The statement "the limit of a constant times a function is the constant times the limit" follows from a combination of two fundamental limit principles. What are they? 43) _____

A) The limit of a product is the product of the limits, and the limit of a quotient is the quotient of the limits.

B) The limit of a function is a constant times a limit, and the limit of a constant is the constant.

C) The limit of a product is the product of the limits, and a constant is continuous.

D) The limit of a constant is the constant, and the limit of a product is the product of the limits.

Find the limit.

44) $\lim_{x \rightarrow 15} \sqrt{3}$ 44) _____

A) $\sqrt{15}$

B) 15

C) $\sqrt{3}$

D) 3

45) $\lim_{x \rightarrow -9} (5x - 4)$ 45) _____

A) -41

B) -49

C) 49

D) 41

46) $\lim_{x \rightarrow -15} (6 - 5x)$ 46) _____

A) 81

B) -81

C) 69

D) -69

Give an appropriate answer.

47) Let $\lim_{x \rightarrow -8} f(x) = -9$ and $\lim_{x \rightarrow -8} g(x) = -3$. Find $\lim_{x \rightarrow -8} [f(x) - g(x)]$. 47) _____
A) -8 B) -9 C) -12 D) -6

48) Let $\lim_{x \rightarrow -7} f(x) = -10$ and $\lim_{x \rightarrow -7} g(x) = 6$. Find $\lim_{x \rightarrow -7} [f(x) \cdot g(x)]$. 48) _____
A) -4 B) -7 C) 6 D) -60

49) Let $\lim_{x \rightarrow -9} f(x) = -4$ and $\lim_{x \rightarrow -9} g(x) = -2$. Find $\lim_{x \rightarrow -9} \frac{f(x)}{g(x)}$. 49) _____
A) $\frac{1}{2}$ B) -9 C) -2 D) 2

50) Let $\lim_{x \rightarrow 5} f(x) = 169$. Find $\lim_{x \rightarrow 5} \sqrt{f(x)}$. 50) _____
A) 169 B) 3.6056 C) 13 D) 5

51) Let $\lim_{x \rightarrow 5} f(x) = -3$ and $\lim_{x \rightarrow 5} g(x) = 1$. Find $\lim_{x \rightarrow 5} [f(x) + g(x)]^2$. 51) _____
A) -4 B) -2 C) 4 D) 10

52) Let $\lim_{x \rightarrow 10} f(x) = 1024$. Find $\lim_{x \rightarrow 10} \sqrt[5]{f(x)}$. 52) _____
A) 10 B) 4 C) 5 D) 1024

53) Let $\lim_{x \rightarrow -6} f(x) = -1$ and $\lim_{x \rightarrow -6} g(x) = -1$. Find $\lim_{x \rightarrow -6} \left[\frac{-5f(x) - 10g(x)}{7 + g(x)} \right]$. 53) _____
A) $-\frac{5}{6}$ B) $\frac{5}{2}$ C) -6 D) $-\frac{65}{7}$

Find the limit.

54) $\lim_{x \rightarrow 2} (x^3 + 5x^2 - 7x + 1)$ 54) _____
A) 15 B) does not exist C) 29 D) 0

55) $\lim_{x \rightarrow 2} (2x^5 - 3x^4 + 4x^3 + x^2 + 5)$ 55) _____
A) 153 B) 25 C) -7 D) 57

56) $\lim_{x \rightarrow -1} \frac{x}{3x + 2}$ 56) _____
A) 0 B) does not exist C) $-\frac{1}{5}$ D) 1

- 57) $\lim_{x \rightarrow 0} \frac{x^3 - 6x + 8}{x - 2}$ 57) _____
 A) 4 B) Does not exist C) 0 D) -4
- 58) $\lim_{x \rightarrow 1} \frac{3x^2 + 7x - 2}{3x^2 - 4x - 2}$ 58) _____
 A) $-\frac{7}{4}$ B) 0 C) $-\frac{8}{3}$ D) Does not exist
- 59) $\lim_{x \rightarrow 1} (x + 2)^2(x - 3)^3$ 59) _____
 A) -8 B) 576 C) -72 D) 64
- 60) $\lim_{x \rightarrow 7} \sqrt{x^2 + 12x + 36}$ 60) _____
 A) 13 B) does not exist C) 169 D) ± 13
- 61) $\lim_{x \rightarrow -6} \sqrt{4x + 45}$ 61) _____
 A) $\sqrt{21}$ B) -21 C) 21 D) $-\sqrt{21}$
- 62) $\lim_{h \rightarrow 0} \frac{2}{\sqrt{3h + 4} + 2}$ 62) _____
 A) Does not exist B) 1/2 C) 2 D) 1
- 63) $\lim_{x \rightarrow 0} \frac{\sqrt{1 + x} - 1}{x}$ 63) _____
 A) 1/4 B) 1/2 C) Does not exist D) 0

Determine the limit by sketching an appropriate graph.

- 64) $\lim_{x \rightarrow 7^-} f(x)$, where $f(x) = \begin{cases} -2x + 4 & \text{for } x < 7 \\ 4x + 5 & \text{for } x \geq 7 \end{cases}$ 64) _____
 A) 33 B) 6 C) 5 D) -10
- 65) $\lim_{x \rightarrow 3^+} f(x)$, where $f(x) = \begin{cases} -2x + 0 & \text{for } x < 3 \\ 3x + 1 & \text{for } x \geq 3 \end{cases}$ 65) _____
 A) 2 B) 10 C) -6 D) 1
- 66) $\lim_{x \rightarrow 3^+} f(x)$, where $f(x) = \begin{cases} x^2 + 6 & \text{for } x \neq 3 \\ 0 & \text{for } x = 3 \end{cases}$ 66) _____
 A) 3 B) 9 C) 15 D) 0

67) $\lim_{x \rightarrow 6^-} f(x)$, where $f(x) = \begin{cases} \sqrt{9-x^2} & 0 \leq x < 3 \\ 3 & 3 \leq x < 6 \\ 6 & x = 6 \end{cases}$ 67) _____
 A) 0 B) 3 C) 6 D) Does not exist

68) $\lim_{x \rightarrow -4^+} f(x)$, where $f(x) = \begin{cases} 2x & -4 \leq x < 0, \text{ or } 0 < x \leq 1 \\ 2 & x = 0 \\ 0 & x < -4 \text{ or } x > 1 \end{cases}$ 68) _____
 A) Does not exist B) -0 C) 2 D) -8

Find the limit, if it exists.

69) $\lim_{x \rightarrow 0} \frac{x^3 + 12x^2 - 5x}{5x}$ 69) _____
 A) Does not exist B) -1 C) 0 D) 5

70) $\lim_{x \rightarrow 1} \frac{x^4 - 1}{x - 1}$ 70) _____
 A) Does not exist B) 0 C) 4 D) 2

71) $\lim_{x \rightarrow 2} \frac{x^2 - 4}{x - 2}$ 71) _____
 A) 2 B) 4 C) Does not exist D) 1

72) $\lim_{x \rightarrow -8} \frac{x^2 + 17x + 72}{x + 8}$ 72) _____
 A) Does not exist B) 272 C) 1 D) 17

73) $\lim_{x \rightarrow 6} \frac{x^2 + 3x - 54}{x - 6}$ 73) _____
 A) 3 B) Does not exist C) 0 D) 15

74) $\lim_{x \rightarrow 1} \frac{x^2 + 8x - 9}{x^2 - 1}$ 74) _____
 A) 0 B) - 4 C) Does not exist D) 5

75) $\lim_{x \rightarrow 1} \frac{x^2 - 1}{x^2 - 6x + 5}$ 75) _____
 A) $-\frac{1}{2}$ B) 0 C) $-\frac{1}{4}$ D) Does not exist

76) $\lim_{x \rightarrow 3} \frac{x^2 - 9x + 18}{x^2 - 8x + 15}$ 76) _____
 A) Does not exist B) $-\frac{3}{2}$ C) $\frac{3}{2}$ D) $-\frac{9}{2}$

77) $\lim_{h \rightarrow 0} \frac{(x+h)^3 - x^3}{h}$ 77) _____
 A) $3x^2 + 3xh + h^2$ B) $3x^2$ C) 0 D) Does not exist

78) $\lim_{x \rightarrow 10} \frac{|10-x|}{10-x}$ 78) _____
 A) 0 B) Does not exist C) 1 D) -1

Provide an appropriate response.

79) It can be shown that the inequalities $-x \leq x \cos\left(\frac{1}{x}\right) \leq x$ hold for all values of $x \geq 0$. 79) _____

Find $\lim_{x \rightarrow 0} x \cos\left(\frac{1}{x}\right)$ if it exists.

- A) 1 B) 0.0007 C) 0 D) does not exist

80) The inequality $1 - \frac{x^2}{2} < \frac{\sin x}{x} < 1$ holds when x is measured in radians and $|x| < 1$. 80) _____

Find $\lim_{x \rightarrow 0} \frac{\sin x}{x}$ if it exists.

- A) does not exist B) 1 C) 0.0007 D) 0

81) If $x^3 \leq f(x) \leq x$ for x in $[-1,1]$, find $\lim_{x \rightarrow 0} f(x)$ if it exists. 81) _____

- A) does not exist B) -1 C) 1 D) 0

Compute the values of $f(x)$ and use them to determine the indicated limit.

82) If $f(x) = x^2 + 8x - 2$, find $\lim_{x \rightarrow 2} f(x)$. 82) _____

x	1.9	1.99	1.999	2.001	2.01	2.1
f(x)						

A)

x	1.9	1.99	1.999	2.001	2.01	2.1
f(x)	5.043	5.364	5.396	5.404	5.436	5.763

; limit = ∞

B)

x	1.9	1.99	1.999	2.001	2.01	2.1
f(x)	16.692	17.592	17.689	17.710	17.808	18.789

; limit = 17.70

C)

x	1.9	1.99	1.999	2.001	2.01	2.1
f(x)	5.043	5.364	5.396	5.404	5.436	5.763

; limit = 5.40

D)

x	1.9	1.99	1.999	2.001	2.01	2.1
f(x)	16.810	17.880	17.988	18.012	18.120	19.210

; limit = 18.0

83) If $f(x) = \frac{x^4 - 1}{x - 1}$, find $\lim_{x \rightarrow 1} f(x)$.

83) _____

x	0.9	0.99	0.999	1.001	1.01	1.1
f(x)						

A)

x	0.9	0.99	0.999	1.001	1.01	1.1
f(x)	1.032	1.182	1.198	1.201	1.218	1.392

; limit = ∞

B)

x	0.9	0.99	0.999	1.001	1.01	1.1
f(x)	3.439	3.940	3.994	4.006	4.060	4.641

; limit = 4.0

C)

x	0.9	0.99	0.999	1.001	1.01	1.1
f(x)	4.595	5.046	5.095	5.105	5.154	5.677

; limit = 5.10

D)

x	0.9	0.99	0.999	1.001	1.01	1.1
f(x)	1.032	1.182	1.198	1.201	1.218	1.392

; limit = 1.210

84) If $f(x) = \frac{x^3 - 6x + 8}{x - 2}$, find $\lim_{x \rightarrow 0} f(x)$.

84) _____

x	-0.1	-0.01	-0.001	0.001	0.01	0.1
f(x)						

A)

x	-0.1	-0.01	-0.001	0.001	0.01	0.1
f(x)	-2.18529	-2.10895	-2.10090	-2.99910	-2.09096	-2.00574

; limit = -2.10

B)

x	-0.1	-0.01	-0.001	0.001	0.01	0.1
f(x)	-1.22843	-1.20298	-1.20030	-1.19970	-1.19699	-1.16858

; limit = ∞

C)

x	-0.1	-0.01	-0.001	0.001	0.01	0.1
f(x)	-4.09476	-4.00995	-4.00100	-3.99900	-3.98995	-3.89526

; limit = -4.0

D)

x	-0.1	-0.01	-0.001	0.001	0.01	0.1
f(x)	-1.22843	-1.20298	-1.20030	-1.19970	-1.19699	-1.16858

; limit = -1.20

85) If $f(x) = \frac{x-4}{\sqrt{x}-2}$, find $\lim_{x \rightarrow 4} f(x)$.

85) _____

x	3.9	3.99	3.999	4.001	4.01	4.1
f(x)						

A)

x	3.9	3.99	3.999	4.001	4.01	4.1	
f(x)	3.97484	3.99750	3.99975	4.00025	4.00250	4.02485	; limit = 4.0

B)

x	3.9	3.99	3.999	4.001	4.01	4.1	
f(x)	1.19245	1.19925	1.19993	1.20007	1.20075	1.20745	; limit = 1.20

C)

x	3.9	3.99	3.999	4.001	4.01	4.1	
f(x)	1.19245	1.19925	1.19993	1.20007	1.20075	1.20745	; limit = ∞

D)

x	3.9	3.99	3.999	4.001	4.01	4.1	
f(x)	5.07736	5.09775	5.09978	5.10022	5.10225	5.12236	; limit = 5.10

86) If $f(x) = x^2 - 5$, find $\lim_{x \rightarrow 0} f(x)$.

86) _____

x	-0.1	-0.01	-0.001	0.001	0.01	0.1
f(x)						

A)

x	-0.1	-0.01	-0.001	0.001	0.01	0.1	
f(x)	-1.4970	-1.4999	-1.5000	-1.5000	-1.4999	-1.4970	; limit = ∞

B)

x	-0.1	-0.01	-0.001	0.001	0.01	0.1	
f(x)	-2.9910	-2.9999	-3.0000	-3.0000	-2.9999	-2.9910	; limit = -3.0

C)

x	-0.1	-0.01	-0.001	0.001	0.01	0.1	
f(x)	-1.4970	-1.4999	-1.5000	-1.5000	-1.4999	-1.4970	; limit = -15.0

D)

x	-0.1	-0.01	-0.001	0.001	0.01	0.1	
f(x)	-4.9900	-4.9999	-5.0000	-5.0000	-4.9999	-4.9900	; limit = -5.0

87) If $f(x) = \frac{\sqrt{x+1}}{x+1}$, find $\lim_{x \rightarrow 1} f(x)$.

87) _____

x	0.9	0.99	0.999	1.001	1.01	1.1
f(x)						

A)

x	0.9	0.99	0.999	1.001	1.01	1.1
f(x)	0.21764	0.21266	0.21219	0.21208	0.21160	0.20702

; limit = ∞

B)

x	0.9	0.99	0.999	1.001	1.01	1.1
f(x)	0.72548	0.70888	0.70728	0.70693	0.70535	0.69007

; limit = 0.7071

C)

x	0.9	0.99	0.999	1.001	1.01	1.1
f(x)	0.21764	0.21266	0.21219	0.21208	0.21160	0.20702

; limit = 0.21213

D)

x	0.9	0.99	0.999	1.001	1.01	1.1
f(x)	2.15293	2.13799	2.13656	2.13624	2.13481	2.12106

; limit = 2.13640

88) If $f(x) = \sqrt{x} - 2$, find $\lim_{x \rightarrow 4} f(x)$.

88) _____

x	3.9	3.99	3.999	4.001	4.01	4.1
f(x)						

A)

x	3.9	3.99	3.999	4.001	4.01	4.1
f(x)	1.47736	1.49775	1.49977	1.50022	1.50225	1.52236

; limit = 1.50

B)

x	3.9	3.99	3.999	4.001	4.01	4.1
f(x)	-0.02516	-0.00250	-0.00025	0.00025	0.00250	0.02485

; limit = 0

C)

x	3.9	3.99	3.999	4.001	4.01	4.1
f(x)	3.9000	2.9000	1.9000	2.0000	3.0000	4.0000

; limit = ∞

D)

x	3.9	3.99	3.999	4.001	4.01	4.1
f(x)	3.9000	2.9000	1.9000	2.0000	3.0000	4.0000

; limit = 1.95

For the function f whose graph is given, determine the limit.

89) Find $\lim_{x \rightarrow -1^-} f(x)$ and $\lim_{x \rightarrow -1^+} f(x)$.

89) _____

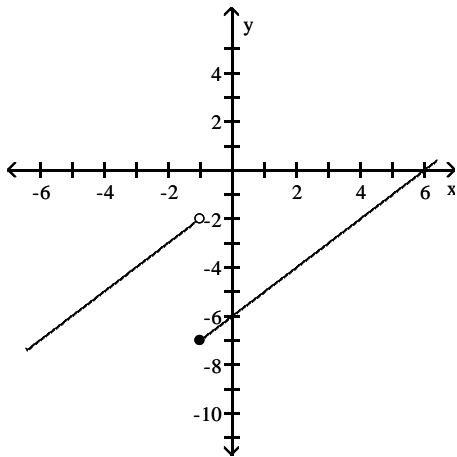

A) -7; -5

B) -5; -2

C) -7; -2

D) -2; -7

90) Find $\lim_{x \rightarrow 2^-} f(x)$ and $\lim_{x \rightarrow 2^+} f(x)$.

90) _____

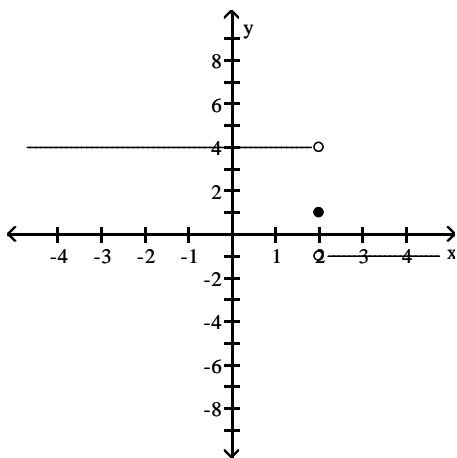

A) does not exist; does not exist

B) 4; -1

C) -1; 4

D) 1; 1

91) Find $\lim_{x \rightarrow 2^-} f(x)$.

91) _____

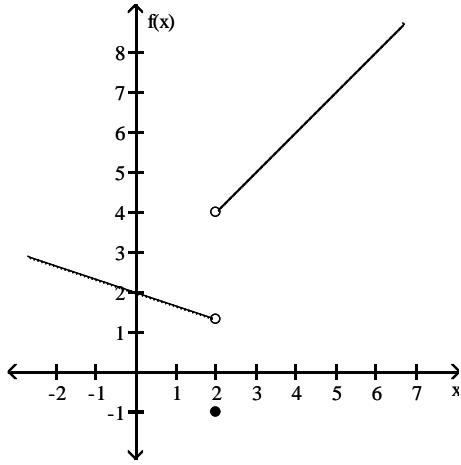

- A) -1
- B) 4
- C) 1.3
- D) 2.3

92) Find $\lim_{x \rightarrow 1^-} f(x)$.

92) _____

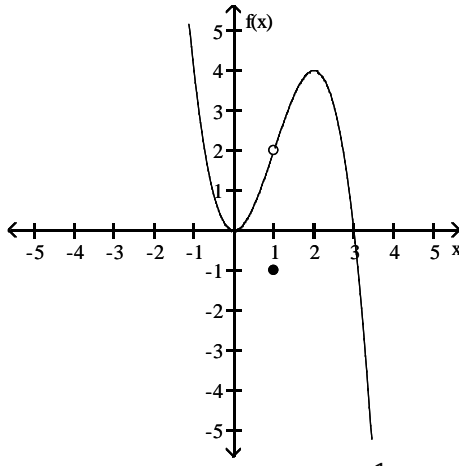

- A) 2
- B) $\frac{1}{2}$
- C) -1
- D) does not exist

93) Find $\lim_{x \rightarrow 1^+} f(x)$.

93) _____

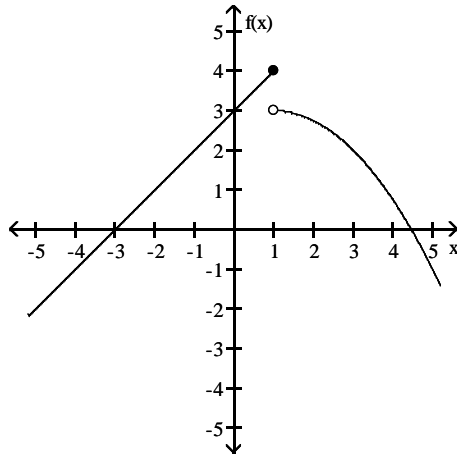

A) does not exist

B) 4

C) $3\frac{1}{2}$

D) 3

94) Find $\lim_{x \rightarrow 0} f(x)$.

94) _____

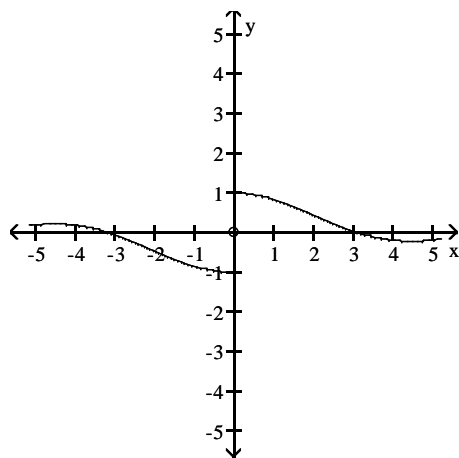

A) does not exist

B) 0

C) 1

D) -1

95) Find $\lim_{x \rightarrow 0} f(x)$.

95) _____

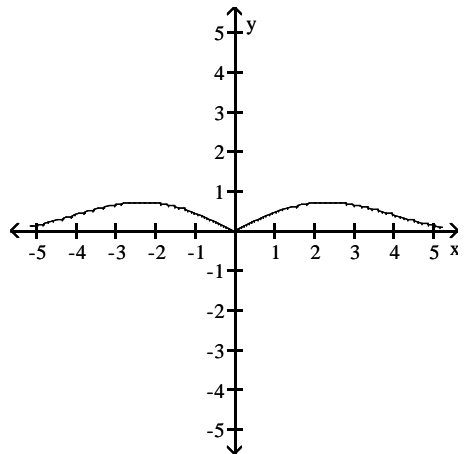

- A) does not exist B) 1 C) -1 D) 0

96) Find $\lim_{x \rightarrow 0} f(x)$.

96) _____

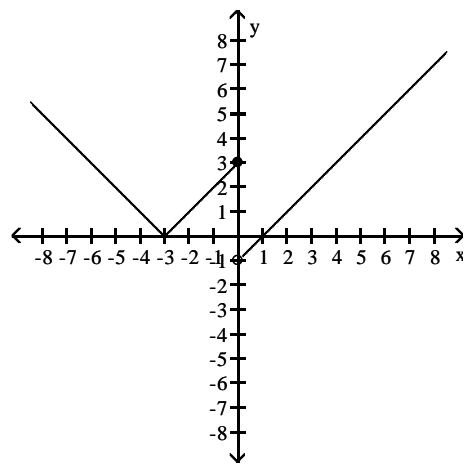

- A) -3 B) does not exist C) 0 D) 3

97) Find $\lim_{x \rightarrow -1} f(x)$.

97) _____

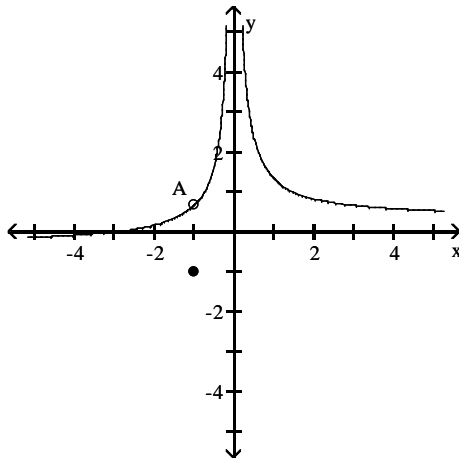

- A) does not exist B) $\frac{2}{3}$ C) $-\frac{2}{3}$ D) -1

98) Find $\lim_{x \rightarrow -\infty} f(x)$.

98) _____

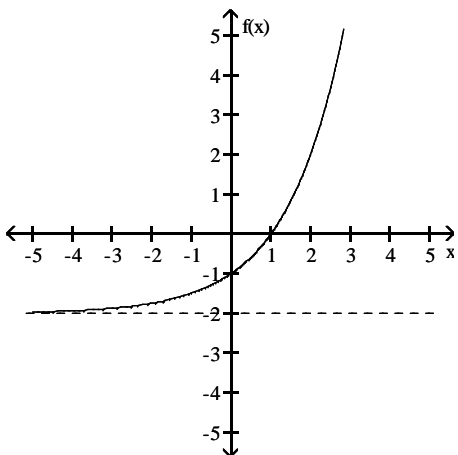

- A) -2 B) 0 C) does not exist D) $-\infty$

Find the limit.

99) $\lim_{x \rightarrow -2} \frac{1}{x+2}$

99) _____

- A) 1/2 B) Does not exist C) $-\infty$ D) ∞

100) $\lim_{x \rightarrow -9^-} \frac{1}{x+9}$

100) _____

- A) -1 B) 0 C) ∞ D) $-\infty$

101) $\lim_{x \rightarrow 10^+} \frac{1}{(x-10)^2}$

101) _____

- A) -1 B) ∞ C) 0 D) $-\infty$

102) $\lim_{x \rightarrow -1^-} \frac{1}{x^2 - 1}$ 102) _____
 A) -1 B) ∞ C) $-\infty$ D) 0

103) $\lim_{x \rightarrow 3^+} \frac{1}{x^2 - 9}$ 103) _____
 A) $-\infty$ B) 1 C) 0 D) ∞

104) $\lim_{x \rightarrow (\pi/2)^+} \tan x$ 104) _____
 A) 1 B) 0 C) ∞ D) $-\infty$

105) $\lim_{x \rightarrow (-\pi/2)^-} \sec x$ 105) _____
 A) 1 B) ∞ C) $-\infty$ D) 0

106) $\lim_{x \rightarrow 0^+} (1 + \csc x)$ 106) _____
 A) 0 B) 1 C) ∞ D) Does not exist

107) $\lim_{x \rightarrow 0} (1 - \cot x)$ 107) _____
 A) $-\infty$ B) ∞ C) 0 D) Does not exist

108) $\lim_{x \rightarrow 1^-} \frac{x^2 - 6x + 5}{x^3 - x}$ 108) _____
 A) $-\infty$ B) ∞ C) 0 D) -2

109) $\lim_{x \rightarrow 0^-} \frac{x^2 - 3x + 2}{x^3 - 4x}$ 109) _____
 A) ∞ B) 0 C) Does not exist D) $-\infty$

Find all vertical asymptotes of the given function.

110) $f(x) = \frac{2x}{x - 9}$ 110) _____
 A) none B) $x = 9$ C) $x = 2$ D) $x = -9$

111) $f(x) = \frac{x + 8}{x^2 - 36}$ 111) _____
 A) $x = -6, x = 6$ B) $x = 36, x = -8$
 C) $x = -6, x = 6, x = -8$ D) $x = 0, x = 36$

- 112) $f(x) = \frac{x+6}{x^2+9}$ 112) _____
 A) $x = -3, x = 3$ B) $x = -3, x = 3, x = -6$
 C) $x = -3, x = -6$ D) none
- 113) $g(x) = \frac{x+11}{x^2+36x}$ 113) _____
 A) $x = 0, x = -6, x = 6$ B) $x = -36, x = -11$
 C) $x = 0, x = -36$ D) $x = -6, x = 6$
- 114) $f(x) = \frac{x(x-1)}{x^3+49x}$ 114) _____
 A) $x = 0, x = -49$ B) $x = 0$
 C) $x = 0, x = -7, x = 7$ D) $x = -7, x = 7$
- 115) $R(x) = \frac{-3x^2}{x^2+5x-24}$ 115) _____
 A) $x = -8, x = 3, x = -3$ B) $x = -8, x = 3$
 C) $x = -24$ D) $x = 8, x = -3$
- 116) $R(x) = \frac{x-1}{x^3+2x^2-8x}$ 116) _____
 A) $x = -2, x = 0, x = 4$ B) $x = -4, x = 2$
 C) $x = -2, x = -30, x = 4$ D) $x = -4, x = 0, x = 2$
- 117) $f(x) = \frac{-2x(x+2)}{3x^2-4x-7}$ 117) _____
 A) $x = \frac{7}{3}, x = -1$ B) $x = \frac{3}{7}, x = -1$ C) $x = -\frac{3}{7}, x = 1$ D) $x = -\frac{7}{3}, x = 1$
- 118) $f(x) = \frac{x-4}{16x-x^3}$ 118) _____
 A) $x = 0, x = 4$ B) $x = -4, x = 4$
 C) $x = 0, x = -4, x = 4$ D) $x = 0, x = -4$
- 119) $f(x) = \frac{-x^2+16}{x^2+5x+4}$ 119) _____
 A) $x = 1, x = -4$ B) $x = -1, x = -4$ C) $x = -1, x = 4$ D) $x = -1$

Choose the graph that represents the given function without using a graphing utility.

120) $f(x) = \frac{x}{x-2}$

120) _____

A)

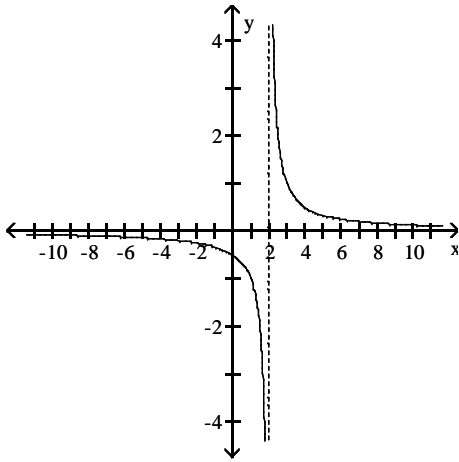

B)

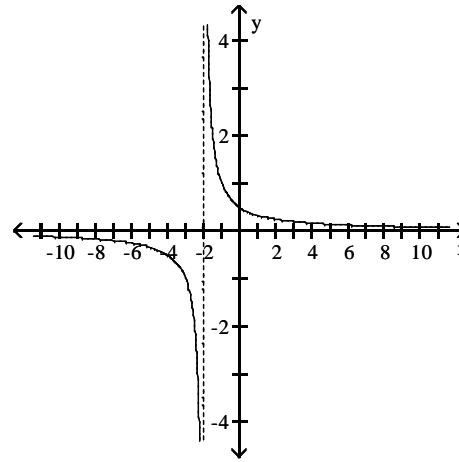

C)

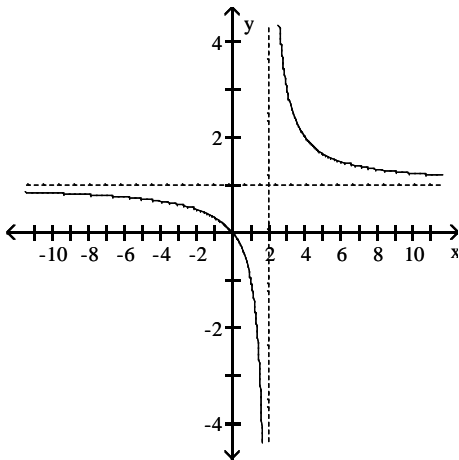

D)

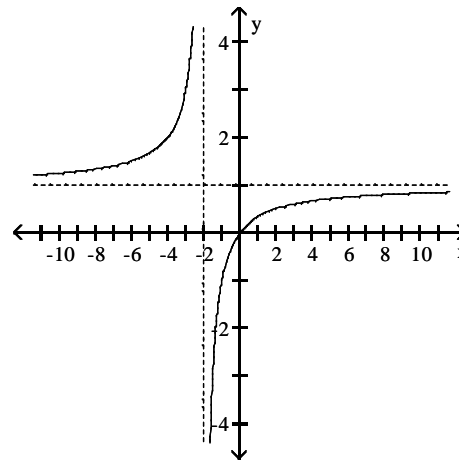

121) $f(x) = \frac{x}{x^2 + x + 1}$

121) _____

A)

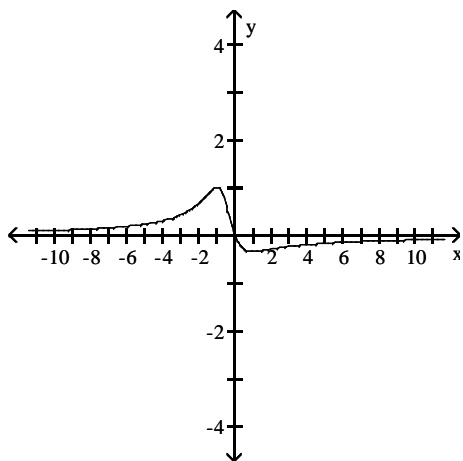

B)

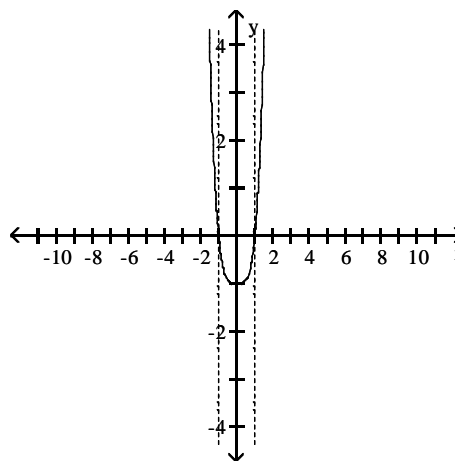

C)

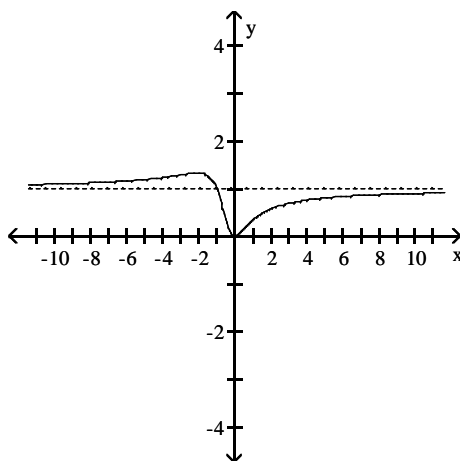

D)

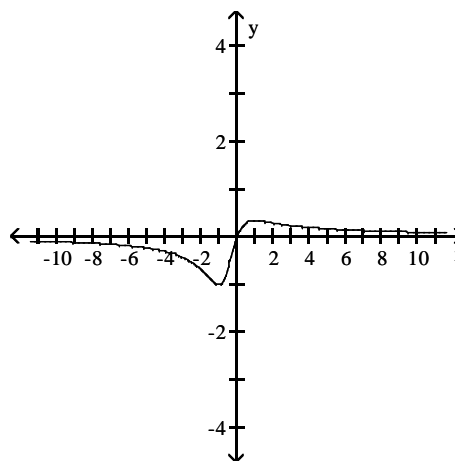

122) $f(x) = \frac{x^2 - 1}{x^3}$

122) _____

A)

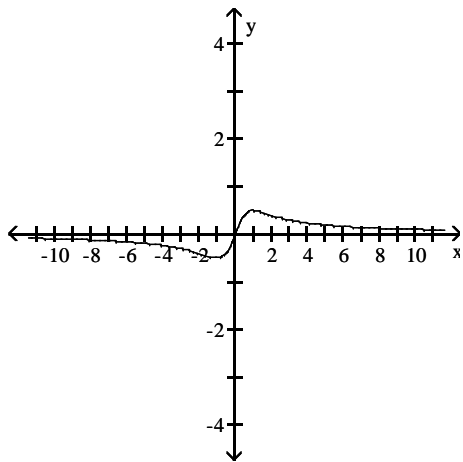

B)

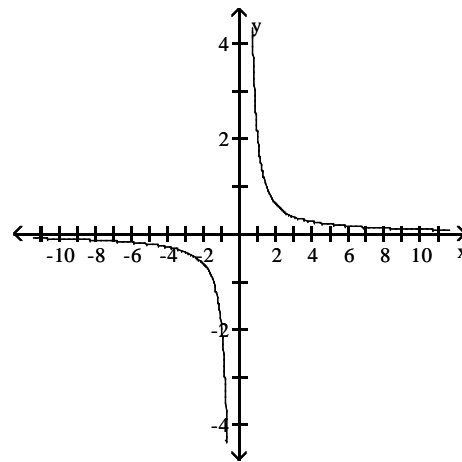

C)

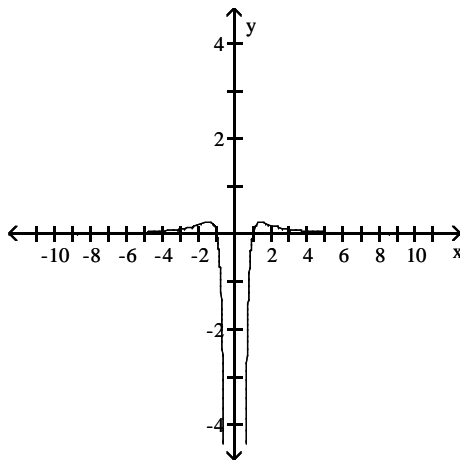

D)

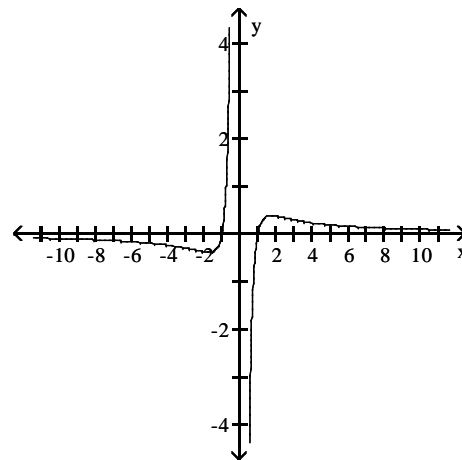

123) $f(x) = \frac{1}{x+1}$

123) _____

A)

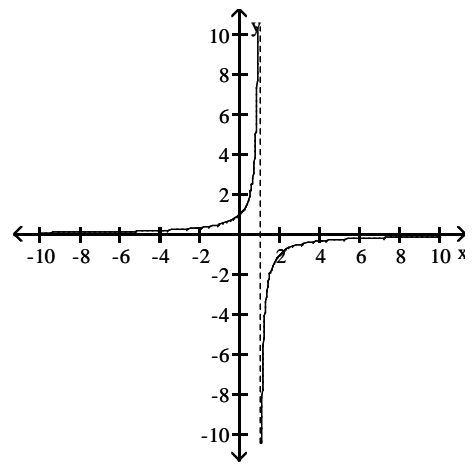

B)

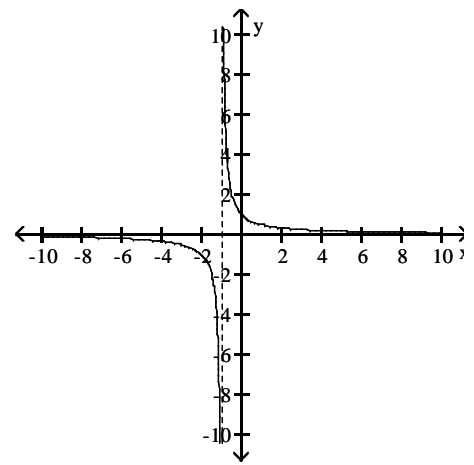

C)

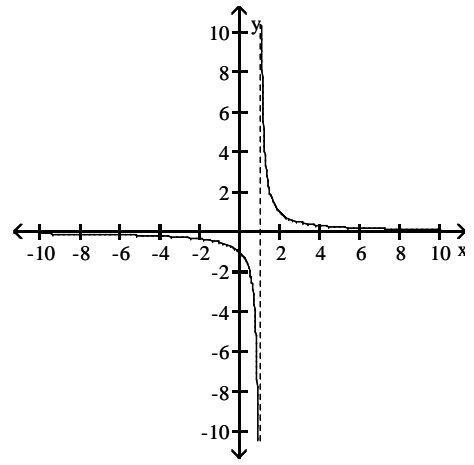

D)

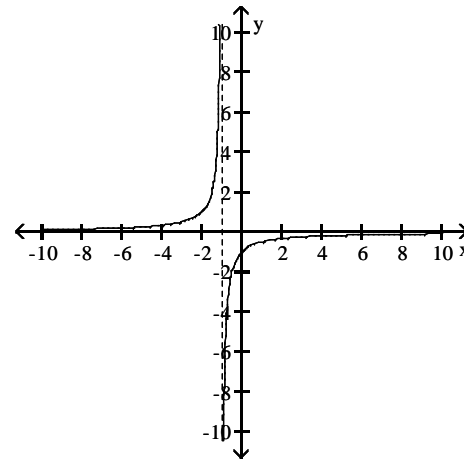

124) $f(x) = \frac{x-1}{x+1}$

124) _____

A)

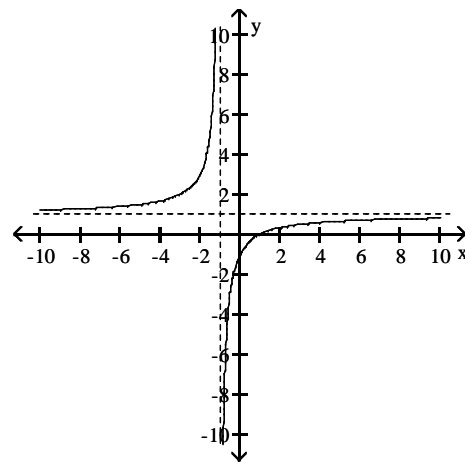

B)

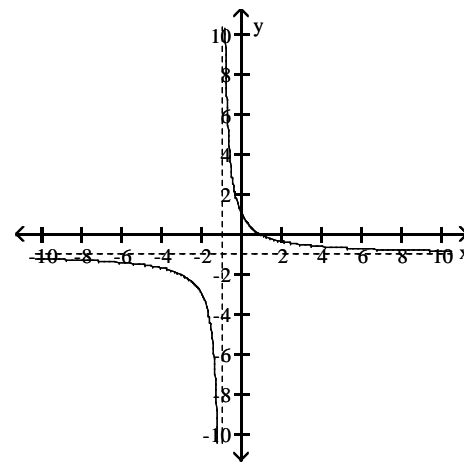

C)

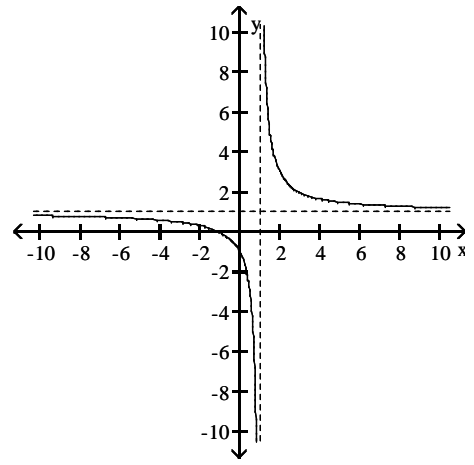

D)

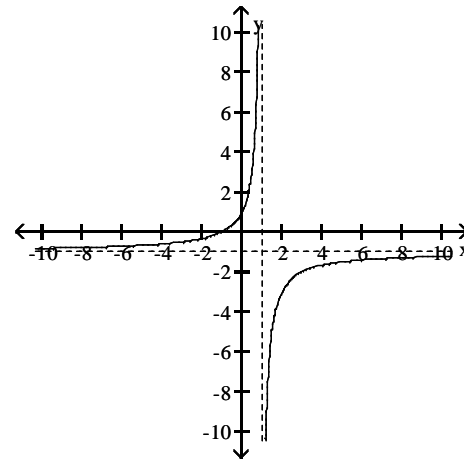

125) $f(x) = \frac{1}{(x+2)^2}$

125) _____

A)

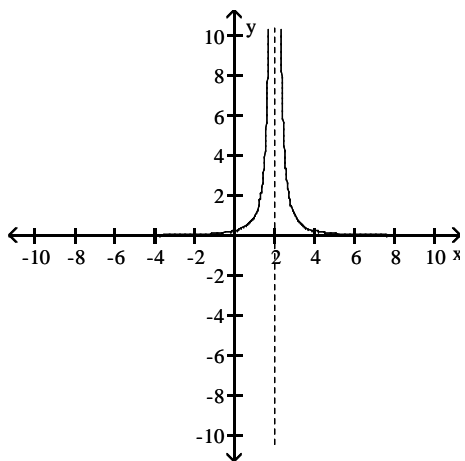

B)

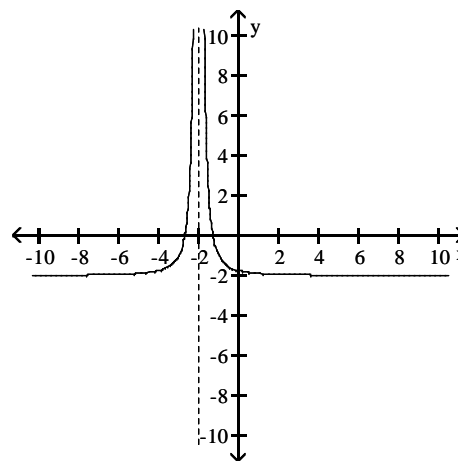

C)

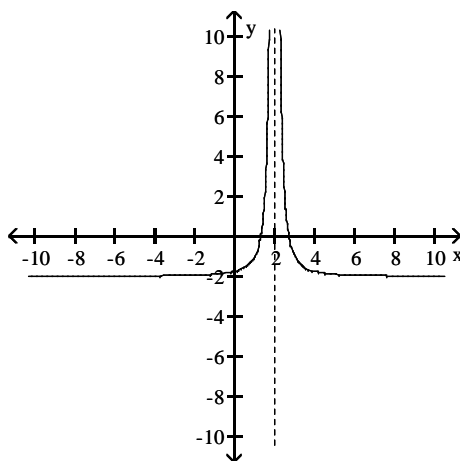

D)

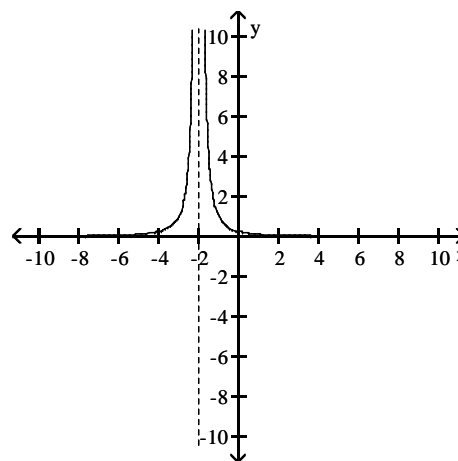

126) $f(x) = \frac{2x^2}{4 - x^2}$

126) _____

A)

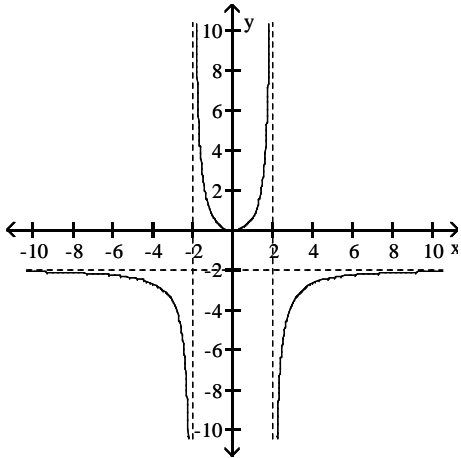

B)

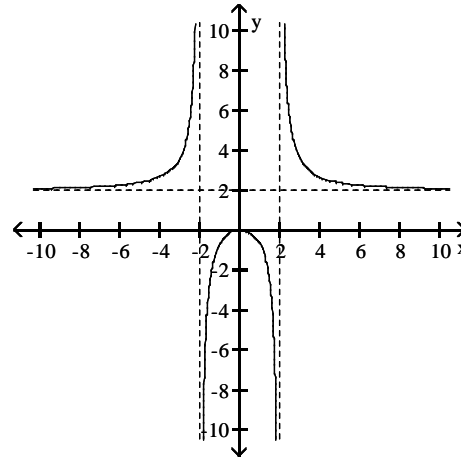

C)

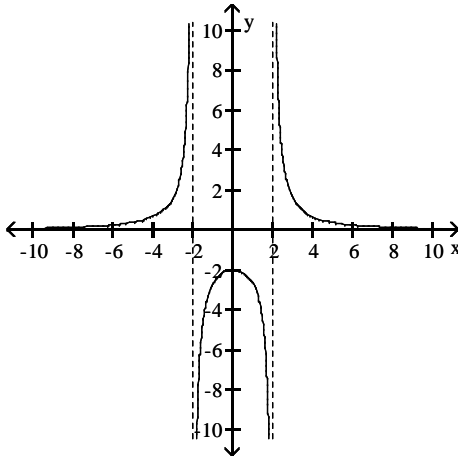

D)

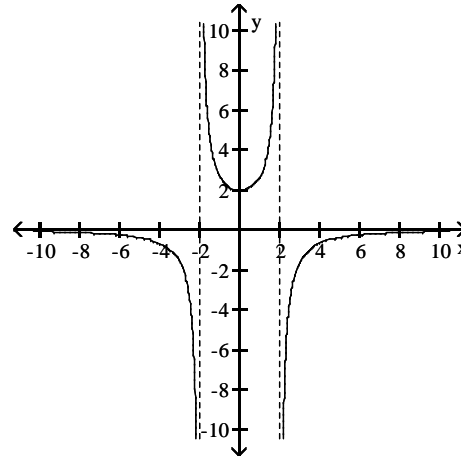

Find the limit.

127) $\lim_{x \rightarrow \infty} \frac{7}{x} - 5$

127) _____

A) -12

B) 2

C) 5

D) -5

128) $\lim_{x \rightarrow -\infty} \frac{3}{5 - (1/x^2)}$

128) _____

A) $\frac{3}{5}$

B) $-\infty$

C) 3

D) $\frac{3}{4}$

129) $\lim_{x \rightarrow -\infty} \frac{-4 + (3/x)}{7 - (1/x^2)}$

129) _____

A) $-\infty$

B) $-\frac{4}{7}$

C) ∞

D) $\frac{4}{7}$

130) $\lim_{x \rightarrow \infty} \frac{x^2 - 4x + 19}{x^3 - 8x^2 + 13}$ 130) _____
 A) $\frac{19}{13}$ B) 1 C) ∞ D) 0

131) $\lim_{x \rightarrow -\infty} \frac{-9x^2 + 6x + 10}{-16x^2 - 8x + 19}$ 131) _____
 A) $\frac{9}{16}$ B) ∞ C) $\frac{10}{19}$ D) 1

132) $\lim_{x \rightarrow \infty} \frac{6x + 1}{15x - 7}$ 132) _____
 A) $-\frac{1}{7}$ B) $\frac{2}{5}$ C) 0 D) ∞

133) $\lim_{x \rightarrow \infty} \frac{2x^3 - 2x^2 + 3x}{-x^3 - 2x + 7}$ 133) _____
 A) $\frac{3}{2}$ B) 2 C) -2 D) ∞

134) $\lim_{x \rightarrow -\infty} \frac{5x^3 + 3x^2}{x - 7x^2}$ 134) _____
 A) 5 B) $-\infty$ C) ∞ D) $-\frac{3}{7}$

135) $\lim_{x \rightarrow -\infty} \frac{\cos 3x}{x}$ 135) _____
 A) $-\infty$ B) 3 C) 1 D) 0

Divide numerator and denominator by the highest power of x in the denominator to find the limit.

136) $\lim_{x \rightarrow \infty} \sqrt{\frac{9x^2}{4 + 49x^2}}$ 136) _____
 A) $\frac{3}{7}$ B) does not exist C) $\frac{9}{4}$ D) $\frac{9}{49}$

137) $\lim_{x \rightarrow \infty} \sqrt{\frac{16x^2 + x - 3}{(x - 9)(x + 1)}}$ 137) _____
 A) 16 B) 0 C) ∞ D) 4

138) $\lim_{x \rightarrow \infty} \frac{-5\sqrt{x} + x^{-1}}{4x - 5}$ 138) _____
 A) $-\frac{5}{4}$ B) $\frac{1}{4}$ C) ∞ D) 0

139) $\lim_{x \rightarrow \infty} \frac{-4x^{-1} - 2x^{-3}}{-2x^{-2} + x^{-5}}$ 139) _____
 A) 0 B) $-\infty$ C) ∞ D) 2

140) $\lim_{x \rightarrow -\infty} \frac{\sqrt[3]{x} - 3x + 6}{-4x + x^{2/3} - 6}$ 140) _____
 A) $\frac{3}{4}$ B) $-\infty$ C) $\frac{4}{3}$ D) 0

141) $\lim_{t \rightarrow \infty} \frac{\sqrt{4t^2 - 8}}{t - 2}$ 141) _____
 A) 8 B) 4 C) 2 D) does not exist

142) $\lim_{t \rightarrow \infty} \frac{\sqrt{64t^2 - 512}}{t - 8}$ 142) _____
 A) does not exist B) 512 C) 8 D) 64

143) $\lim_{x \rightarrow \infty} \frac{2x + 7}{\sqrt{7x^2 + 1}}$ 143) _____
 A) ∞ B) $\frac{2}{7}$ C) 0 D) $\frac{2}{\sqrt{7}}$

Find all horizontal asymptotes of the given function, if any.

144) $h(x) = \frac{4x - 9}{x - 6}$ 144) _____
 A) $y = 6$ B) $y = 0$
 C) $y = 4$ D) no horizontal asymptotes

145) $h(x) = 7 - \frac{5}{x}$ 145) _____
 A) $y = 5$ B) $y = 7$
 C) $x = 0$ D) no horizontal asymptotes

146) $g(x) = \frac{x^2 + 7x - 2}{x - 2}$ 146) _____
 A) $y = 0$ B) $y = 1$
 C) $y = 2$ D) no horizontal asymptotes

147) $h(x) = \frac{6x^2 - 5x - 6}{4x^2 - 3x + 3}$ 147) _____
 A) $y = \frac{3}{2}$ B) $y = \frac{5}{3}$
 C) $y = 0$ D) no horizontal asymptotes

- 148) $h(x) = \frac{2x^4 - 4x^2 - 4}{3x^5 - 9x + 9}$ 148) _____
- A) $y = \frac{4}{9}$ B) $y = 0$
- C) $y = \frac{2}{3}$ D) no horizontal asymptotes
- 149) $h(x) = \frac{8x^3 - 2x}{4x^3 - 6x + 3}$ 149) _____
- A) $y = 2$ B) $y = \frac{1}{3}$
- C) $y = 0$ D) no horizontal asymptotes
- 150) $h(x) = \frac{6x^3 - 9x - 7}{4x^2 + 4}$ 150) _____
- A) $y = 6$ B) $y = 0$
- C) $y = \frac{3}{2}$ D) no horizontal asymptotes
- 151) $g(x) = \frac{7x + 1}{x^2 - 36}$ 151) _____
- A) no horizontal asymptotes B) $y = 0$
- C) $y = 7$ D) $y = -6, y = 6$
- 152) $R(x) = \frac{-3x^2 + 1}{x^2 + 4x - 12}$ 152) _____
- A) $y = 0$ B) $y = -6, y = 2$
- C) $y = -3$ D) no horizontal asymptotes
- 153) $f(x) = \frac{x^2 - 4}{16x - x^4}$ 153) _____
- A) $y = 0$ B) no horizontal asymptotes
- C) $y = -1$ D) $y = -4, y = 4$
- 154) $f(x) = \frac{49x^4 + x^2 - 7}{x - x^3}$ 154) _____
- A) $y = -49$ B) $y = -1, y = 1$
- C) no horizontal asymptotes D) $y = 0$

SHORT ANSWER. Write the word or phrase that best completes each statement or answers the question.

Sketch the graph of a function $y = f(x)$ that satisfies the given conditions.

155) $f(0) = 0, f(1) = 3, f(-1) = -3, \lim_{x \rightarrow -\infty} f(x) = -2, \lim_{x \rightarrow \infty} f(x) = 2.$

155) _____

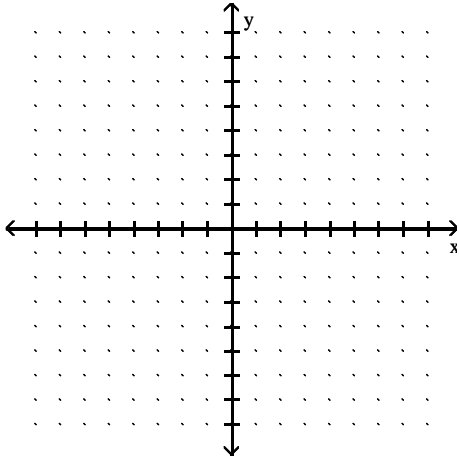

156) $f(0) = 0, f(1) = 2, f(-1) = 2, \lim_{x \rightarrow \pm\infty} f(x) = -2.$

156) _____

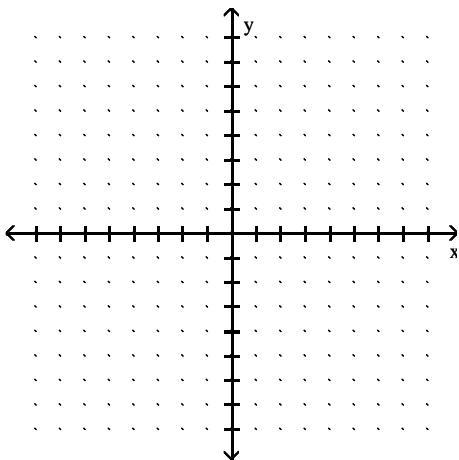

157) $f(0) = 4, f(1) = -4, f(-1) = -4, \lim_{x \rightarrow \pm\infty} f(x) = 0.$

157) _____

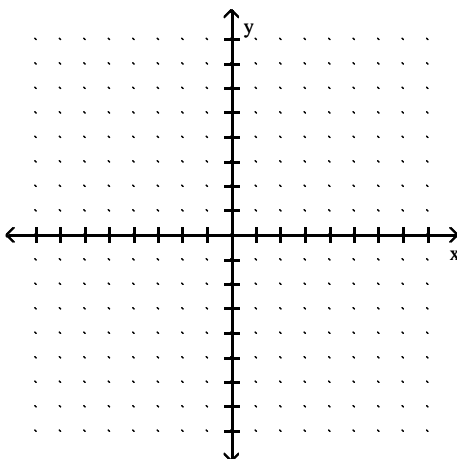

158) $f(0) = 0$, $\lim_{x \rightarrow \pm\infty} f(x) = 0$, $\lim_{x \rightarrow 6^-} f(x) = -\infty$, $\lim_{x \rightarrow -6^+} f(x) = -\infty$, $\lim_{x \rightarrow 6^+} f(x) = \infty$,

158) _____

$\lim_{x \rightarrow -6^-} f(x) = \infty$.

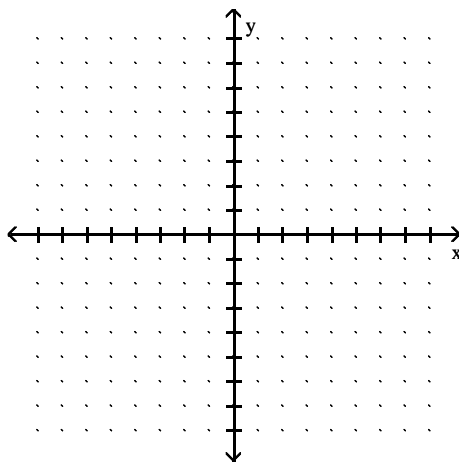

MULTIPLE CHOICE. Choose the one alternative that best completes the statement or answers the question.

Find all points where the function is discontinuous.

159)

159) _____

A) $x = 4, x = 2$

B) $x = 2$

C) None

D) $x = 4$

160)

160) _____

A) $x = -2, x = 1$

B) None

C) $x = 1$

D) $x = -2$

161)

161) _____

A) $x = -2, x = 0$

B) $x = 0, x = 2$

C) $x = 2$

D) $x = -2, x = 0, x = 2$

162)

162) _____

A) $x = -2, x = 6$

B) None

C) $x = -2$

D) $x = 6$

163)

163) _____

A) None

B) $x = 4$

C) $x = 1, x = 4, x = 5$

D) $x = 1, x = 5$

164)

164) _____

A) $x = 0, x = 1$

B) $x = 0$

C) $x = 1$

D) None

165)

165) _____

A) None

B) $x = 0, x = 3$

C) $x = 3$

D) $x = 0$

166)

166) _____

A) $x = 2$

B) $x = -2$

C) $x = -2, x = 2$

D) None

167)

167) _____

- A) $x = 0$
- C) None

- B) $x = -2, x = 2$
- D) $x = -2, x = 0, x = 2$

Provide an appropriate response.

168) Is f continuous at $f(1)$?

168) _____

$$f(x) = \begin{cases} -x^2 + 1, & -1 \leq x < 0 \\ 4x, & 0 < x < 1 \\ -2, & x = 1 \\ -4x + 8, & 1 < x < 3 \\ 1, & 3 < x < 5 \end{cases}$$

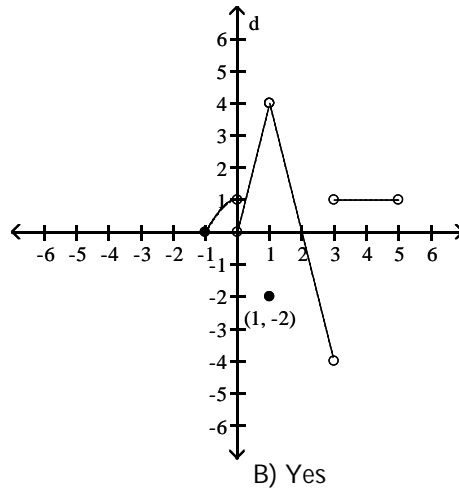

A) No

B) Yes

169) Is f continuous at $f(0)$?

169) _____

$$f(x) = \begin{cases} -x^2 + 1, & -1 \leq x < 0 \\ 5x, & 0 < x < 1 \\ -5, & x = 1 \\ -5x + 10, & 1 < x < 3 \\ 1, & 3 < x < 5 \end{cases}$$

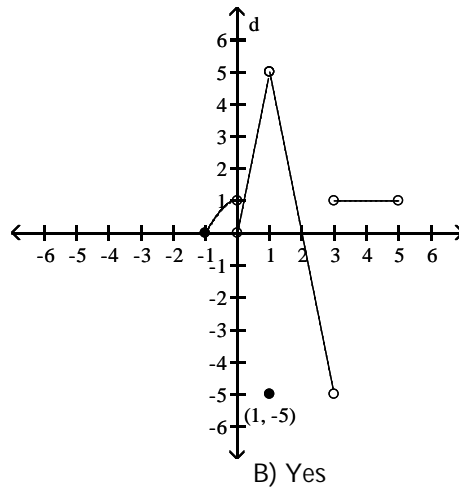

A) No

B) Yes

170) Is f continuous at $x = 0$?

170) _____

$$f(x) = \begin{cases} x^3, & -2 < x \leq 0 \\ -2x, & 0 \leq x < 2 \\ 5, & 2 < x \leq 4 \\ 0, & x = 2 \end{cases}$$

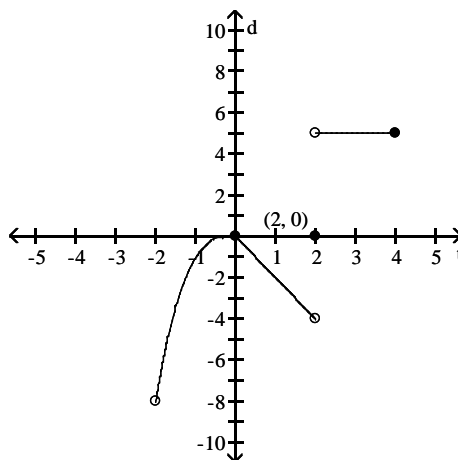

A) No

B) Yes

171) Is f continuous at $x = 4$?

171) _____

$$f(x) = \begin{cases} x^3, & -2 < x \leq 0 \\ -2x, & 0 \leq x < 2 \\ 1, & 2 < x \leq 4 \\ 0, & x = 2 \end{cases}$$

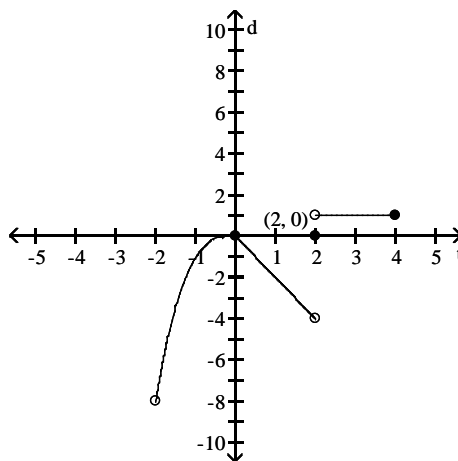

A) Yes

B) No

Find the intervals on which the function is continuous.

172) $y = \frac{2}{x+5} - 2x$

172) _____

- A) discontinuous only when $x = -5$
- C) discontinuous only when $x = 5$

- B) continuous everywhere
- D) discontinuous only when $x = -7$

173) $y = \frac{1}{(x+5)^2 + 10}$

173) _____

- A) discontinuous only when $x = -5$
- C) continuous everywhere

- B) discontinuous only when $x = 35$
- D) discontinuous only when $x = -40$

174) $y = \frac{x+2}{x^2 - 6x + 8}$

174) _____

- A) discontinuous only when $x = 2$
- C) discontinuous only when $x = -2$ or $x = 4$

- B) discontinuous only when $x = -4$ or $x = 2$
- D) discontinuous only when $x = 2$ or $x = 4$

175) $y = \frac{3}{x^2 - 4}$ 175) _____

- A) discontinuous only when $x = -4$ or $x = 4$
 C) discontinuous only when $x = 4$

- B) discontinuous only when $x = -2$
 D) discontinuous only when $x = -2$ or $x = 2$

176) $y = \frac{3}{|x| + 5} - \frac{x^2}{7}$ 176) _____

- A) discontinuous only when $x = -7$ or $x = -5$
 C) discontinuous only when $x = -5$

- B) continuous everywhere
 D) discontinuous only when $x = -12$

177) $y = \frac{\sin(4\theta)}{2\theta}$ 177) _____

- A) discontinuous only when $\theta = 0$
 C) continuous everywhere

- B) discontinuous only when $\theta = \pi$
 D) discontinuous only when $\theta = \frac{\pi}{2}$

178) $y = \frac{2 \cos \theta}{\theta + 4}$ 178) _____

- A) discontinuous only when $\theta = 4$
 C) continuous everywhere

- B) discontinuous only when $\theta = \frac{\pi}{2}$
 D) discontinuous only when $\theta = -4$

179) $y = \sqrt{10x + 1}$ 179) _____

- A) continuous on the interval $\left[-\frac{1}{10}, \infty\right)$
 C) continuous on the interval $\left[-\infty, -\frac{1}{10}\right]$

- B) continuous on the interval $\left[-\frac{1}{10}, \infty\right)$
 D) continuous on the interval $\left[\frac{1}{10}, \infty\right)$

180) $y = \sqrt[4]{2x - 4}$ 180) _____

- A) continuous on the interval $(2, \infty)$
 C) continuous on the interval $[2, \infty)$

- B) continuous on the interval $(-\infty, 2]$
 D) continuous on the interval $[-2, \infty)$

181) $y = \sqrt{x^2 - 3}$ 181) _____

- A) continuous on the interval $[-\sqrt{3}, \sqrt{3}]$
 B) continuous everywhere
 C) continuous on the interval $[\sqrt{3}, \infty)$
 D) continuous on the intervals $(-\infty, -\sqrt{3}]$ and $[\sqrt{3}, \infty)$

Provide an appropriate response.

182) Is f continuous on $(-2, 4]$?

182) _____

$$f(x) = \begin{cases} x^3, & -2 < x \leq 0 \\ -4x, & 0 \leq x < 2 \\ 6, & 2 < x \leq 4 \\ 0, & x = 2 \end{cases}$$

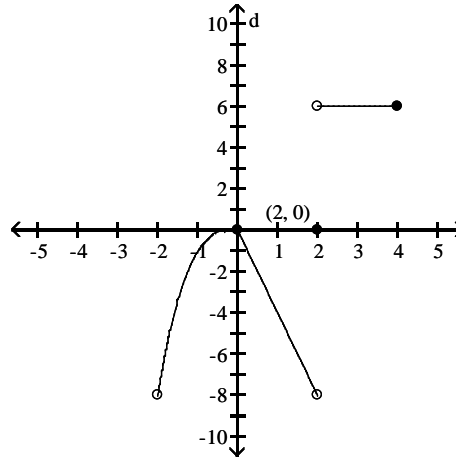

A) No

B) Yes

Find the limit, if it exists.

183) $\lim_{x \rightarrow -3} (x^2 - 16 + \sqrt[3]{x^2 - 36})$

183) _____

A) -4

B) 4

C) Does not exist

D) -10

184) $\lim_{x \rightarrow 7} \sqrt{x^2 + 8x + 16}$

184) _____

A) 121

B) ± 11

C) Does not exist

D) 11

185) $\lim_{x \rightarrow 3} \sqrt{x - 9}$

185) _____

A) Does not exist

B) 0

C) 2.44948974

D) -2.4494897

186) $\lim_{x \rightarrow 8} \sqrt{x^2 - 9}$

186) _____

A) 27.5

B) $\pm\sqrt{55}$

C) $\sqrt{55}$

D) Does not exist

187) $\lim_{x \rightarrow -6^-} \sqrt{x^2 - 36}$

187) _____

A) 3

B) 0

C) $6\sqrt{3}$

D) Does not exist

188) $\lim_{x \rightarrow 5^+} \frac{9\sqrt{(x-5)^3}}{x-5}$

188) _____

A) $9\sqrt{5}$

B) 0

C) 9

D) Does not exist

189) $\lim_{t \rightarrow 1^+} \frac{\sqrt{(t+25)(t-1)^2}}{11t-11}$

189) _____

A) $\frac{\sqrt{26}}{11}$

B) $\frac{1}{11}$

C) 0

D) Does not exist

SHORT ANSWER. Write the word or phrase that best completes each statement or answers the question.

Provide an appropriate response.

190) Use the Intermediate Value Theorem to prove that $5x^3 + 4x^2 + 10x + 10 = 0$ has a solution between -1 and 0. 190) _____

191) Use the Intermediate Value Theorem to prove that $6x^4 + 9x^3 - 5x - 8 = 0$ has a solution between -2 and -1. 191) _____

192) Use the Intermediate Value Theorem to prove that $x(x - 9)^2 = 9$ has a solution between 8 and 10. 192) _____

193) Use the Intermediate Value Theorem to prove that $4 \sin x = x$ has a solution between $\frac{\pi}{2}$ and π . 193) _____

MULTIPLE CHOICE. Choose the one alternative that best completes the statement or answers the question.

Find numbers a and b, or k, so that f is continuous at every point.

194) _____ 194) _____

$$f(x) = \begin{cases} -12, & x < -3 \\ ax + b, & -3 \leq x \leq 1 \\ 8, & x > 1 \end{cases}$$

A) $a = 5, b = 13$

B) $a = -12, b = 8$

C) $a = 5, b = 3$

D) Impossible

195) _____ 195) _____

$$f(x) = \begin{cases} x^2, & x < -3 \\ ax + b, & -3 \leq x \leq 4 \\ x + 12, & x > 4 \end{cases}$$

A) $a = -1, b = 12$

B) $a = 1, b = 12$

C) $a = 1, b = -12$

D) Impossible

196) _____ 196) _____

$$f(x) = \begin{cases} 3x + 8, & \text{if } x < -5 \\ kx + 7, & \text{if } x \geq -5 \end{cases}$$

A) $k = \frac{7}{5}$

B) $k = 4$

C) $k = -\frac{7}{5}$

D) $k = \frac{14}{5}$

197) _____ 197) _____

$$f(x) = \begin{cases} x^2, & \text{if } x \leq 7 \\ x + k, & \text{if } x > 7 \end{cases}$$

A) $k = 56$

B) $k = 42$

C) $k = -7$

D) Impossible

198)

$$f(x) = \begin{cases} x^2, & \text{if } x \leq 8 \\ kx, & \text{if } x > 8 \end{cases}$$

A) $k = 64$

B) $k = \frac{1}{8}$

C) $k = 8$

D) Impossible

198) _____

Solve the problem.199) Select the correct statement for the definition of the limit: $\lim_{x \rightarrow x_0} f(x) = L$

199) _____

means that _____

A) if given any number $\varepsilon > 0$, there exists a number $\delta > 0$, such that for all x , $0 < |x - x_0| < \varepsilon$ implies $|f(x) - L| < \delta$.B) if given any number $\varepsilon > 0$, there exists a number $\delta > 0$, such that for all x , $0 < |x - x_0| < \delta$ implies $|f(x) - L| < \varepsilon$.C) if given any number $\varepsilon > 0$, there exists a number $\delta > 0$, such that for all x , $0 < |x - x_0| < \varepsilon$ implies $|f(x) - L| > \delta$.D) if given a number $\varepsilon > 0$, there exists a number $\delta > 0$, such that for all x , $0 < |x - x_0| < \delta$ implies $|f(x) - L| > \varepsilon$.

200) Identify the incorrect statements about limits.

200) _____

I. The number L is the limit of $f(x)$ as x approaches x_0 if $f(x)$ gets closer to L as x approaches x_0 .II. The number L is the limit of $f(x)$ as x approaches x_0 if, for any $\varepsilon > 0$, there corresponds a $\delta > 0$ such that $|f(x) - L| < \varepsilon$ whenever $0 < |x - x_0| < \delta$.III. The number L is the limit of $f(x)$ as x approaches x_0 if, given any $\varepsilon > 0$, there exists a value of x for which $|f(x) - L| < \varepsilon$.

A) II and III

B) I and III

C) I and II

D) I, II, and III

Use the graph to find a $\delta > 0$ such that for all x , $0 < |x - x_0| < \delta \Rightarrow |f(x) - L| < \varepsilon$.

201)

201) _____

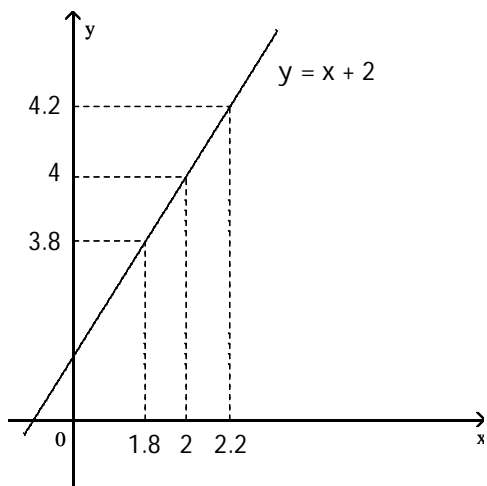

$$\begin{aligned} f(x) &= x + 2 \\ x_0 &= 2 \\ L &= 4 \\ \varepsilon &= 0.2 \end{aligned}$$

NOT TO SCALE

A) 0.1

B) 0.2

C) 2

D) 0.4

202)

202) _____

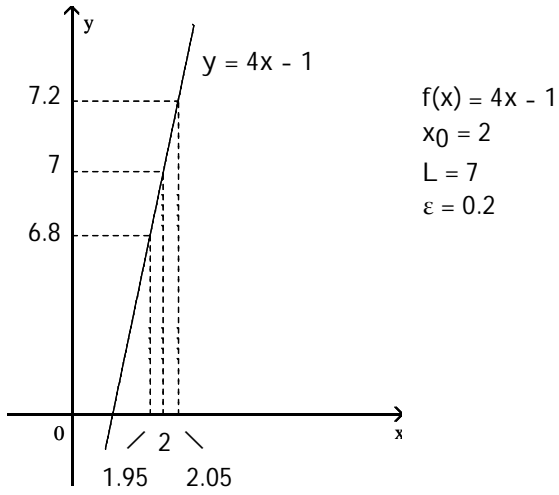

NOT TO SCALE

A) 0.1

B) 0.05

C) 5

D) 0.5

203)

203) _____

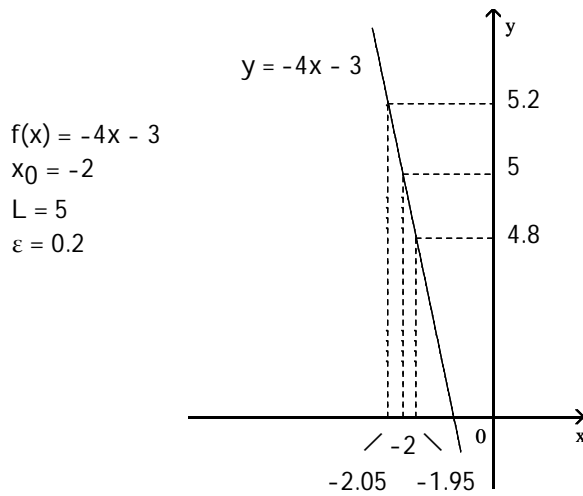

NOT TO SCALE

A) 0.5

B) 0.05

C) 13

D) -0.05

204)

204) _____

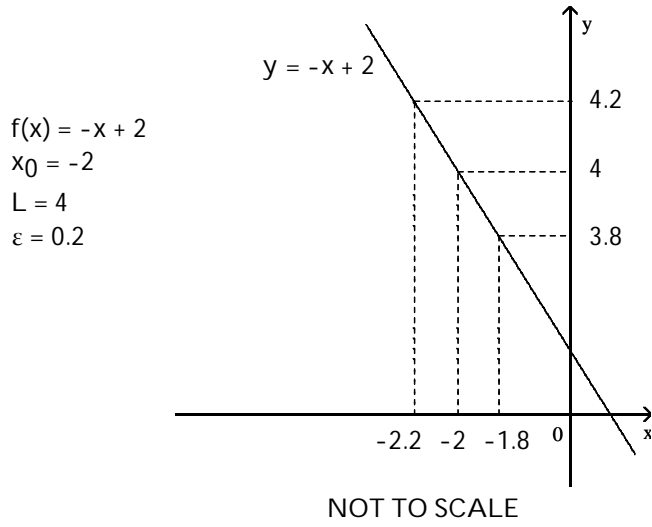

A) -0.2

B) 0.2

C) 0.4

D) 6

205)

205) _____

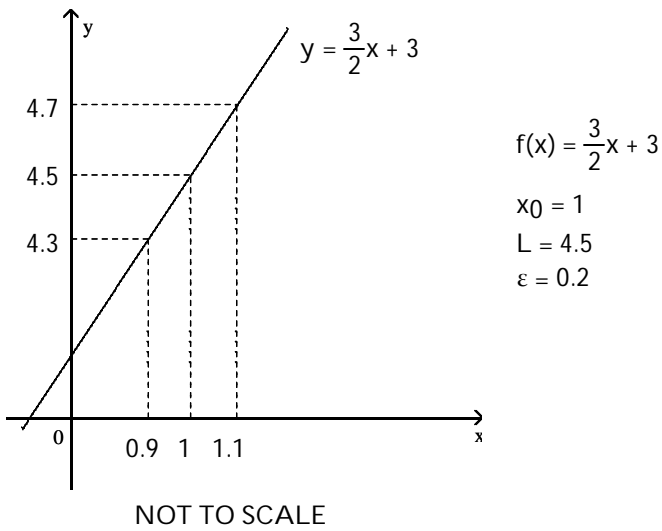

A) -0.2

B) 0.2

C) 3.5

D) 0.1

206)

206) _____

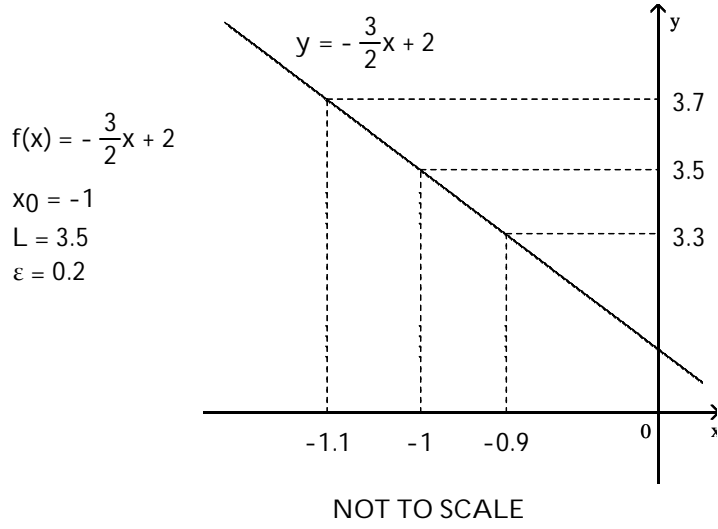

A) 4.5

B) 0.1

C) 0.2

D) -0.2

207)

207) _____

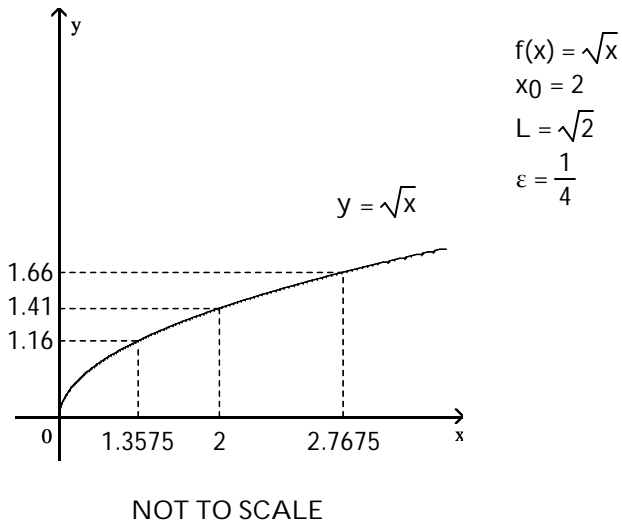

A) 0.7675

B) 0.6425

C) -0.59

D) 1.41

208)

208) _____

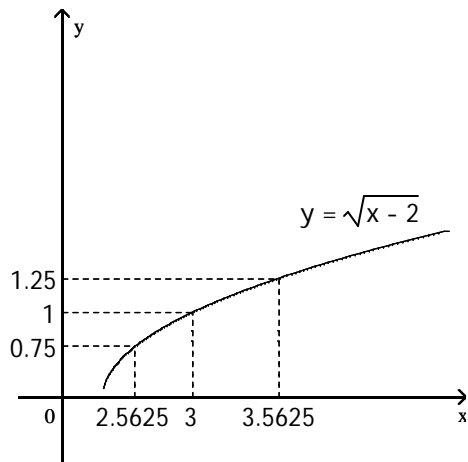

$$f(x) = \sqrt{x-2}$$

$$x_0 = 3$$

$$L = 1$$

$$\varepsilon = \frac{1}{4}$$

NOT TO SCALE

A) 1

B) 2

C) 0.4375

D) 0.5625

209)

209) _____

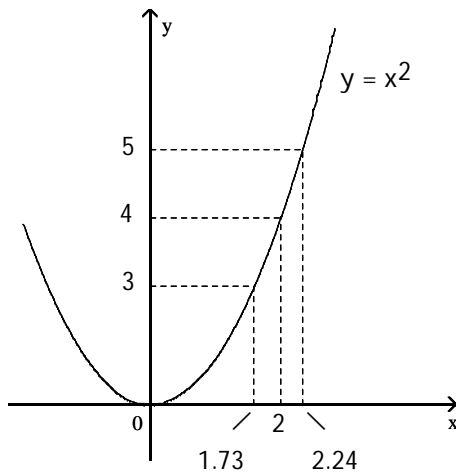

$$f(x) = x^2$$

$$x_0 = 2$$

$$L = 4$$

$$\varepsilon = 1$$

NOT TO SCALE

A) 0.51

B) 0.27

C) 2

D) 0.24

210)

210) _____

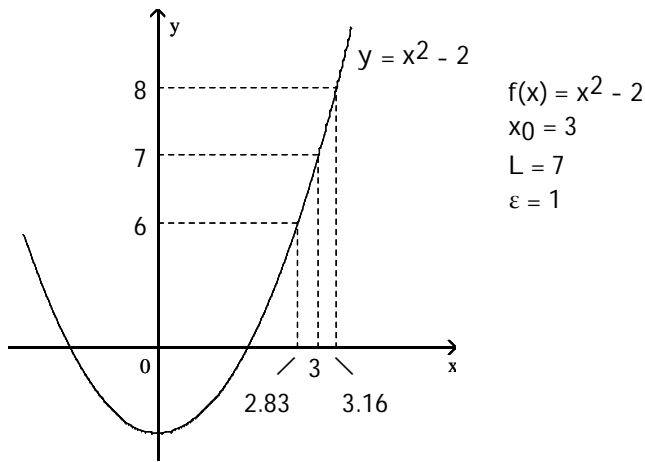

NOT TO SCALE

A) 0.17

B) 4

C) 0.33

D) 0.16

A function $f(x)$, a point x_0 , the limit of $f(x)$ as x approaches x_0 , and a positive number ε is given. Find a number $\delta > 0$ such that for all x , $0 < |x - x_0| < \delta \Rightarrow |f(x) - L| < \varepsilon$.

211) $f(x) = 3x + 10$, $L = 13$, $x_0 = 1$, and $\varepsilon = 0.01$

211) _____

A) 0.003333

B) 0.01

C) 0.016667

D) 0.006667

212) $f(x) = 9x - 7$, $L = 2$, $x_0 = 1$, and $\varepsilon = 0.01$

212) _____

A) 0.001111

B) 0.002222

C) 0.000556

D) 0.01

213) $f(x) = -3x + 9$, $L = 6$, $x_0 = 1$, and $\varepsilon = 0.01$

213) _____

A) 0.003333

B) -0.01

C) 0.013333

D) 0.006667

214) $f(x) = -9x - 7$, $L = -34$, $x_0 = 3$, and $\varepsilon = 0.01$

214) _____

A) 0.000556

B) -0.003333

C) 0.002222

D) 0.001111

215) $f(x) = 2x^2$, $L = 98$, $x_0 = 7$, and $\varepsilon = 0.4$

215) _____

A) 7.01427

B) 0.01427

C) 0.0143

D) 6.9857

SHORT ANSWER. Write the word or phrase that best completes each statement or answers the question.

Prove the limit statement

216) $\lim_{x \rightarrow 5} (2x - 1) = 9$

216) _____

217) $\lim_{x \rightarrow 5} \frac{x^2 - 25}{x - 5} = 10$

217) _____

218) $\lim_{x \rightarrow 7} \frac{3x^2 - 19x - 14}{x - 7} = 23$

218) _____

$$219) \lim_{x \rightarrow 5} \frac{1}{x} = \frac{1}{5}$$

219) _____

Answer Key

Testname: UNTITLED2

- 1) D
- 2) D
- 3) B
- 4) A
- 5) D
- 6) D
- 7) D
- 8) C
- 9) C
- 10) D
- 11) B
- 12) A
- 13) A
- 14) D
- 15) D
- 16) C
- 17) C
- 18) C
- 19) C
- 20) B
- 21) C
- 22) D
- 23) A
- 24) D
- 25) A
- 26) C
- 27) B
- 28) B
- 29) D
- 30) C
- 31) D
- 32) D
- 33) C
- 34) B
- 35) A
- 36) C
- 37) C
- 38) D
- 39) B

40) Answers may vary. One possibility: $\lim_{x \rightarrow 0} 1 - \frac{x^2}{6} = \lim_{x \rightarrow 0} 1 = 1$. According to the squeeze theorem, the function

$\frac{x \sin(x)}{2 - 2 \cos(x)}$, which is squeezed between $1 - \frac{x^2}{6}$ and 1, must also approach 1 as x approaches 0. Thus,

$$\lim_{x \rightarrow 0} \frac{x \sin(x)}{2 - 2 \cos(x)} = 1.$$

- 41) C
- 42) A
- 43) D

Answer Key

Testname: UNTITLED2

- 44) C
- 45) B
- 46) A
- 47) D
- 48) D
- 49) D
- 50) C
- 51) C
- 52) B
- 53) B
- 54) A
- 55) D
- 56) D
- 57) D
- 58) C
- 59) C
- 60) A
- 61) A
- 62) B
- 63) B
- 64) D
- 65) B
- 66) C
- 67) B
- 68) D
- 69) B
- 70) C
- 71) B
- 72) C
- 73) D
- 74) D
- 75) A
- 76) C
- 77) B
- 78) B
- 79) C
- 80) B
- 81) D
- 82) D
- 83) B
- 84) C
- 85) A
- 86) D
- 87) B
- 88) B
- 89) D
- 90) B
- 91) C
- 92) A
- 93) D

Answer Key

Testname: UNTITLED2

- 94) A
- 95) D
- 96) B
- 97) B
- 98) A
- 99) B
- 100) D
- 101) B
- 102) B
- 103) D
- 104) D
- 105) B
- 106) C
- 107) D
- 108) D
- 109) A
- 110) B
- 111) A
- 112) D
- 113) C
- 114) B
- 115) B
- 116) D
- 117) A
- 118) D
- 119) D
- 120) C
- 121) D
- 122) D
- 123) B
- 124) A
- 125) D
- 126) A
- 127) D
- 128) A
- 129) B
- 130) D
- 131) A
- 132) B
- 133) C
- 134) C
- 135) D
- 136) A
- 137) D
- 138) D
- 139) C
- 140) A
- 141) C
- 142) C
- 143) D

Answer Key

Testname: UNTITLED2

144) C

145) B

146) D

147) A

148) B

149) A

150) D

151) B

152) C

153) A

154) C

155) Answers may vary. One possible answer:

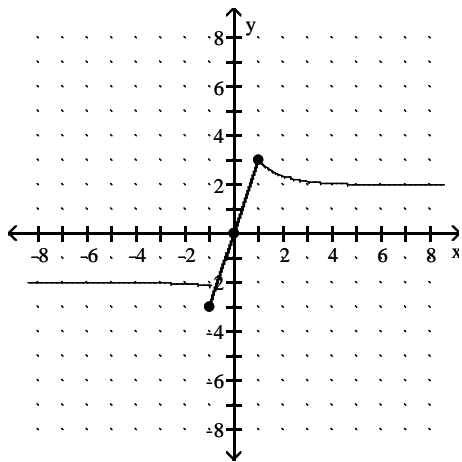

156) Answers may vary. One possible answer:

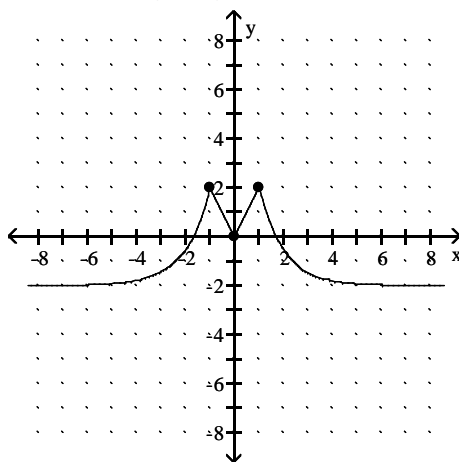

Answer Key

Testname: UNTITLED2

157) Answers may vary. One possible answer:

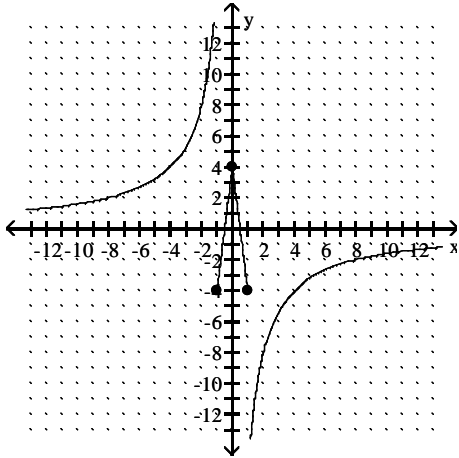

158) Answers may vary. One possible answer:

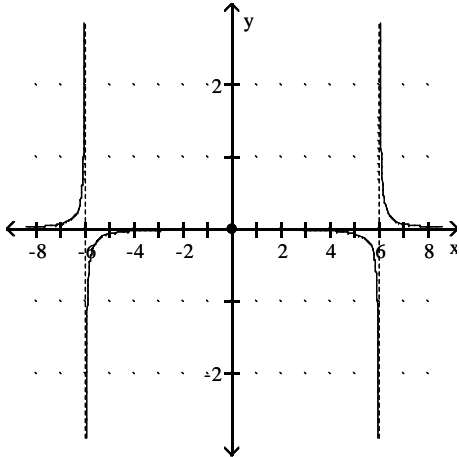

- 159) D
- 160) C
- 161) D
- 162) D
- 163) A
- 164) D
- 165) C
- 166) C
- 167) A
- 168) A
- 169) A
- 170) B
- 171) A
- 172) A
- 173) C
- 174) D
- 175) D
- 176) B
- 177) A
- 178) D
- 179) B

Answer Key

Testname: UNTITLED2

180) C

181) D

182) A

183) D

184) D

185) A

186) C

187) B

188) B

189) A

190) Let $f(x) = 5x^3 + 4x^2 + 10x + 10$ and let $y_0 = 0$. $f(-1) = -1$ and $f(0) = 10$. Since f is continuous on $[-1, 0]$ and since $y_0 = 0$ is between $f(-1)$ and $f(0)$, by the Intermediate Value Theorem, there exists a c in the interval $(-1, 0)$ with the property that $f(c) = 0$. Such a c is a solution to the equation $5x^3 + 4x^2 + 10x + 10 = 0$.

191) Let $f(x) = 6x^4 + 9x^3 - 5x - 8$ and let $y_0 = 0$. $f(-2) = 26$ and $f(-1) = -6$. Since f is continuous on $[-2, -1]$ and since $y_0 = 0$ is between $f(-2)$ and $f(-1)$, by the Intermediate Value Theorem, there exists a c in the interval $(-2, -1)$ with the property that $f(c) = 0$. Such a c is a solution to the equation $6x^4 + 9x^3 - 5x - 8 = 0$.

192) Let $f(x) = x(x - 9)^2$ and let $y_0 = 9$. $f(8) = 8$ and $f(10) = 10$. Since f is continuous on $[8, 10]$ and since $y_0 = 9$ is between $f(8)$ and $f(10)$, by the Intermediate Value Theorem, there exists a c in the interval $(8, 10)$ with the property that $f(c) = 9$. Such a c is a solution to the equation $x(x - 9)^2 = 9$.

193) Let $f(x) = \frac{\sin x}{x}$ and let $y_0 = \frac{1}{4}$. $f\left(\frac{\pi}{2}\right) \approx 0.6366$ and $f(\pi) = 0$. Since f is continuous on $\left[\frac{\pi}{2}, \pi\right]$ and since $y_0 = \frac{1}{4}$ is between $f\left(\frac{\pi}{2}\right)$ and $f(\pi)$, by the Intermediate Value Theorem, there exists a c in the interval $\left(\frac{\pi}{2}, \pi\right)$, with the property that $f(c) = \frac{1}{4}$. Such a c is a solution to the equation $4 \sin x = x$.

194) C

195) B

196) D

197) B

198) C

199) B

200) B

201) B

202) B

203) B

204) B

205) D

206) B

207) B

208) C

209) D

210) D

211) A

212) A

213) A

214) D

215) B

Answer Key

Testname: UNTITLED2

216)

Let $\varepsilon > 0$ be given. Choose $\delta = \varepsilon/2$. Then $0 < |x - 5| < \delta$ implies that

$$\begin{aligned} |(2x - 1) - 9| &= |2x - 10| \\ &= |2(x - 5)| \\ &= 2|x - 5| < 2\delta = \varepsilon \end{aligned}$$

Thus, $0 < |x - 5| < \delta$ implies that $|(2x - 1) - 9| < \varepsilon$ 217) Let $\varepsilon > 0$ be given. Choose $\delta = \varepsilon$. Then $0 < |x - 5| < \delta$ implies that

$$\begin{aligned} \left| \frac{x^2 - 25}{x - 5} - 10 \right| &= \left| \frac{(x - 5)(x + 5)}{x - 5} - 10 \right| \\ &= |(x + 5) - 10| \quad \text{for } x \neq 5 \\ &= |x - 5| < \delta = \varepsilon \end{aligned}$$

Thus, $0 < |x - 5| < \delta$ implies that $\left| \frac{x^2 - 25}{x - 5} - 10 \right| < \varepsilon$ 218) Let $\varepsilon > 0$ be given. Choose $\delta = \varepsilon/3$. Then $0 < |x - 7| < \delta$ implies that

$$\begin{aligned} \left| \frac{3x^2 - 19x - 14}{x - 7} - 23 \right| &= \left| \frac{(x - 7)(3x + 2)}{x - 7} - 23 \right| \\ &= |(3x + 2) - 23| \quad \text{for } x \neq 7 \\ &= |3x - 21| \\ &= |3(x - 7)| \\ &= 3|x - 7| < 3\delta = \varepsilon \end{aligned}$$

Thus, $0 < |x - 7| < \delta$ implies that $\left| \frac{3x^2 - 19x - 14}{x - 7} - 23 \right| < \varepsilon$ 219) Let $\varepsilon > 0$ be given. Choose $\delta = \min\{5/2, 25\varepsilon/2\}$. Then $0 < |x - 5| < \delta$ implies that

$$\begin{aligned} \left| \frac{1}{x} - \frac{1}{5} \right| &= \left| \frac{5 - x}{5x} \right| \\ &= \frac{1}{|x|} \cdot \frac{1}{5} \cdot |x - 5| \\ &< \frac{1}{5/2} \cdot \frac{1}{5} \cdot \frac{25\varepsilon}{2} = \varepsilon \end{aligned}$$

Thus, $0 < |x - 5| < \delta$ implies that $\left| \frac{1}{x} - \frac{1}{5} \right| < \varepsilon$