

MULTIPLE CHOICE. Choose the one alternative that best completes the statement or answers the question.

Find the average velocity of the function over the given interval.

1) $y = x^2 + 8x, [5, 8]$ 1) _____
 A) 16 B) $\frac{128}{3}$ C) 21 D) $\frac{63}{8}$

2) $y = 2x^3 + 5x^2 + 7, [-5, -1]$ 2) _____
 A) - 10 B) $\frac{5}{2}$ C) 32 D) - 128

3) $y = \sqrt{2x}, [2, 8]$ 3) _____
 A) 7 B) $\frac{1}{3}$ C) $-\frac{3}{10}$ D) 2

4) $y = \frac{3}{x-2}, [4, 7]$ 4) _____
 A) $-\frac{3}{10}$ B) 7 C) $\frac{1}{3}$ D) 2

5) $y = 4x^2, \left[0, \frac{7}{4}\right]$ 5) _____
 A) 7 B) $\frac{1}{3}$ C) 2 D) $-\frac{3}{10}$

6) $y = -3x^2 - x, [5, 6]$ 6) _____
 A) -34 B) $-\frac{1}{6}$ C) $\frac{1}{2}$ D) -2

7) $h(t) = \sin(2t), \left[0, \frac{\pi}{4}\right]$ 7) _____
 A) $\frac{2}{\pi}$ B) $\frac{\pi}{4}$ C) $\frac{4}{\pi}$ D) $-\frac{4}{\pi}$

8) $g(t) = 3 + \tan t, \left[-\frac{\pi}{4}, \frac{\pi}{4}\right]$ 8) _____
 A) $-\frac{8}{5}$ B) $\frac{4}{\pi}$ C) 0 D) $-\frac{4}{\pi}$

Use the table to find the instantaneous velocity of y at the specified value of x .

9) $x = 1$.

9) _____

x	y
0	0
0.2	0.02
0.4	0.08
0.6	0.18
0.8	0.32
1.0	0.5
1.2	0.72
1.4	0.98

A) 2

B) 1.5

C) 0.5

D) 1

10) $x = 1$.

10) _____

x	y
0	0
0.2	0.01
0.4	0.04
0.6	0.09
0.8	0.16
1.0	0.25
1.2	0.36
1.4	0.49

A) 1.5

B) 0.5

C) 2

D) 1

11) $x = 1$.

11) _____

x	y
0	0
0.2	0.12
0.4	0.48
0.6	1.08
0.8	1.92
1.0	3
1.2	4.32
1.4	5.88

A) 6

B) 2

C) 8

D) 4

12) $x = 2$.

12) _____

x	y
0	10
0.5	38
1.0	58
1.5	70
2.0	74
2.5	70
3.0	58
3.5	38
4.0	10

- A) -8 B) 4 C) 0 D) 8

13) $x = 1$.

13) _____

x	y
0.900	-0.05263
0.990	-0.00503
0.999	-0.0005
1.000	0.0000
1.001	0.0005
1.010	0.00498
1.100	0.04762

- A) 0.5 B) 1 C) 0 D) -0.5

For the given position function, make a table of average velocities and make a conjecture about the instantaneous velocity at the indicated time.

14) $s(t) = t^2 + 8t - 2$ at $t = 2$

14) _____

t	1.9	1.99	1.999	2.001	2.01	2.1
s(t)						

- A)

t	1.9	1.99	1.999	2.001	2.01	2.1
s(t)	16.692	17.592	17.689	17.710	17.808	18.789

; instantaneous velocity is 17.70
- B)

t	1.9	1.99	1.999	2.001	2.01	2.1
s(t)	5.043	5.364	5.396	5.404	5.436	5.763

; instantaneous velocity is 5.40
- C)

t	1.9	1.99	1.999	2.001	2.01	2.1
s(t)	5.043	5.364	5.396	5.404	5.436	5.763

; instantaneous velocity is ∞
- D)

t	1.9	1.99	1.999	2.001	2.01	2.1
s(t)	16.810	17.880	17.988	18.012	18.120	19.210

; instantaneous velocity is 18.0

15) $s(t) = t^2 - 5$ at $t = 0$

15) _____

t	-0.1	-0.01	-0.001	0.001	0.01	0.1
s(t)						

A)

t	-0.1	-0.01	-0.001	0.001	0.01	0.1
s(t)	-4.9900	-4.9999	-5.0000	-5.0000	-4.9999	-4.9900

; instantaneous velocity is -5.0

B)

t	-0.1	-0.01	-0.001	0.001	0.01	0.1
s(t)	-2.9910	-2.9999	-3.0000	-3.0000	-2.9999	-2.9910

; instantaneous velocity is -3.0

C)

t	-0.1	-0.01	-0.001	0.001	0.01	0.1
s(t)	-1.4970	-1.4999	-1.5000	-1.5000	-1.4999	-1.4970

; instantaneous velocity is -15.0

D)

t	-0.1	-0.01	-0.001	0.001	0.01	0.1
s(t)	-1.4970	-1.4999	-1.5000	-1.5000	-1.4999	-1.4970

; instantaneous velocity is ∞

Find the slope of the curve for the given value of x.

16) $y = x^2 + 5x$, $x = 4$

16) _____

- A) slope is 13 B) slope is $-\frac{4}{25}$ C) slope is -39 D) slope is $\frac{1}{20}$

17) $y = x^2 + 11x - 15$, $x = 1$

17) _____

- A) slope is 13 B) slope is $-\frac{4}{25}$ C) slope is $\frac{1}{20}$ D) slope is -39

18) $y = x^3 - 5x$, $x = 1$

18) _____

- A) slope is 1 B) slope is 3 C) slope is -2 D) slope is -3

19) $y = x^3 - 3x^2 + 4$, $x = 3$

19) _____

- A) slope is 0 B) slope is -9 C) slope is 1 D) slope is 9

20) $y = 2 - x^3$, $x = -1$

20) _____

- A) slope is -1 B) slope is 0 C) slope is -3 D) slope is 3

Solve the problem.

21) Given $\lim_{x \rightarrow 0^-} f(x) = L_1$, $\lim_{x \rightarrow 0^+} f(x) = L_2$, and $L_1 \neq L_2$, which of the following statements is true?

21) _____

- I. $\lim_{x \rightarrow 0} f(x) = L_1$
 II. $\lim_{x \rightarrow 0} f(x) = L_2$
 III. $\lim_{x \rightarrow 0} f(x)$ does not exist.

- A) I B) II C) none D) III

22) Given $\lim_{x \rightarrow 0^-} f(x) = L_l$, $\lim_{x \rightarrow 0^+} f(x) = L_r$, and $L_l = L_r$, which of the following statements is false? 22) _____

I. $\lim_{x \rightarrow 0} f(x) = L_l$
 II. $\lim_{x \rightarrow 0} f(x) = L_r$
 III. $\lim_{x \rightarrow 0} f(x)$ does not exist.

A) I B) II C) none D) III

23) If $\lim_{x \rightarrow 0} f(x) = L$, which of the following expressions are true? 23) _____

I. $\lim_{x \rightarrow 0^-} f(x)$ does not exist.
 II. $\lim_{x \rightarrow 0^+} f(x)$ does not exist.
 III. $\lim_{x \rightarrow 0^-} f(x) = L$
 IV. $\lim_{x \rightarrow 0^+} f(x) = L$

A) I and II only B) III and IV only C) I and IV only D) II and III only

24) What conditions, when present, are sufficient to conclude that a function $f(x)$ has a limit as x approaches some value of a ? 24) _____

A) The limit of $f(x)$ as $x \rightarrow a$ from the left exists, the limit of $f(x)$ as $x \rightarrow a$ from the right exists, and these two limits are the same.
 B) Either the limit of $f(x)$ as $x \rightarrow a$ from the left exists or the limit of $f(x)$ as $x \rightarrow a$ from the right exists
 C) The limit of $f(x)$ as $x \rightarrow a$ from the left exists, the limit of $f(x)$ as $x \rightarrow a$ from the right exists, and at least one of these limits is the same as $f(a)$.
 D) $f(a)$ exists, the limit of $f(x)$ as $x \rightarrow a$ from the left exists, and the limit of $f(x)$ as $x \rightarrow a$ from the right exists.

Use the graph to evaluate the limit.

25) $\lim_{x \rightarrow -1} f(x)$

25) _____

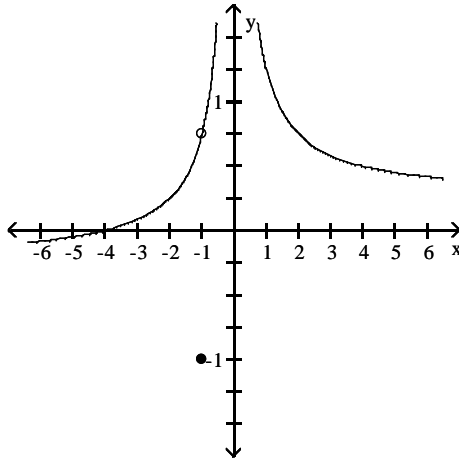

A) ∞

B) $-\frac{3}{4}$

C) -1

D) $\frac{3}{4}$

26) $\lim_{x \rightarrow 0} f(x)$

26) _____

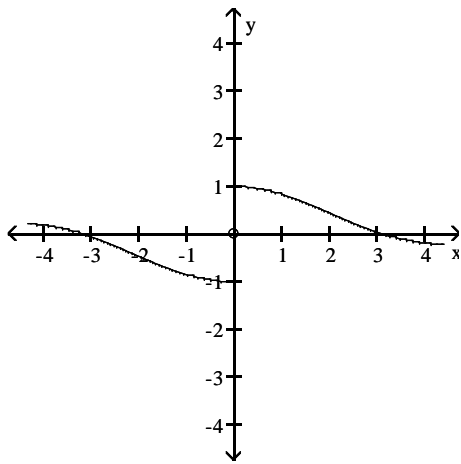

A) 0

B) 1

C) -1

D) does not exist

27) $\lim_{x \rightarrow 0} f(x)$

27) _____

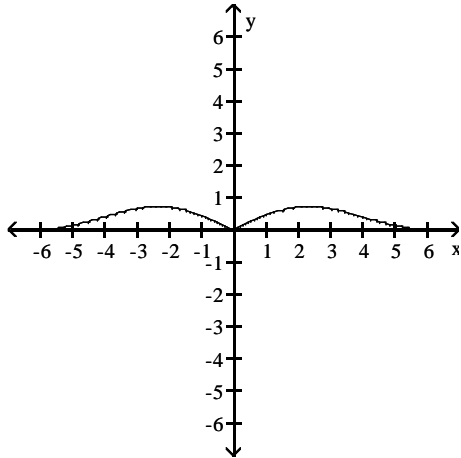

A) -1

B) 1

C) does not exist

D) 0

28) $\lim_{x \rightarrow 0} f(x)$

28) _____

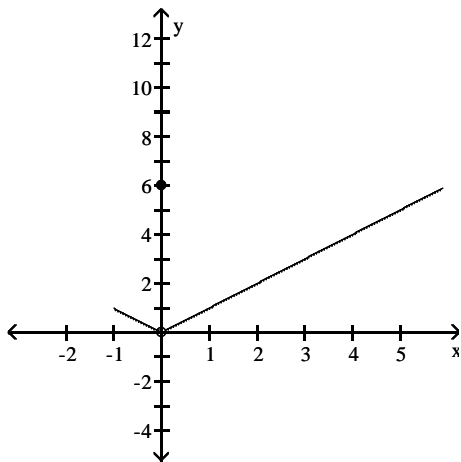

A) 6

B) -1

C) 0

D) does not exist

29) $\lim_{x \rightarrow 0} f(x)$

29) _____

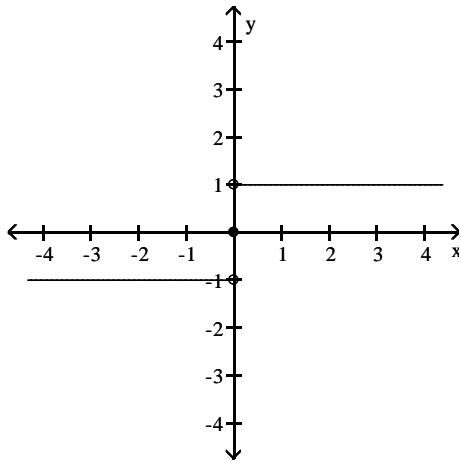

A) ∞

B) -1

C) does not exist

D) 1

30) $\lim_{x \rightarrow 0} f(x)$

30) _____

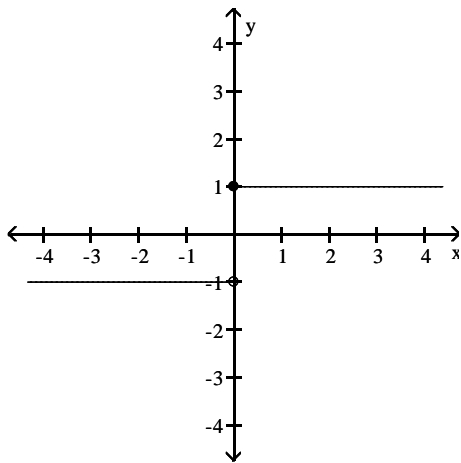

A) -1

B) ∞

C) 1

D) does not exist

31) $\lim_{x \rightarrow 0} f(x)$

31) _____

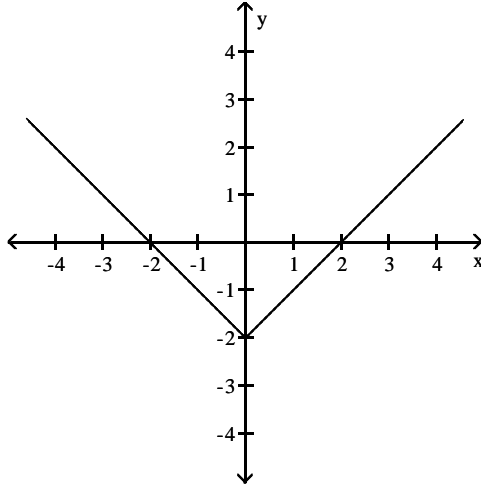

- A) does not exist B) -2 C) 2 D) 0

32) $\lim_{x \rightarrow 0} f(x)$

32) _____

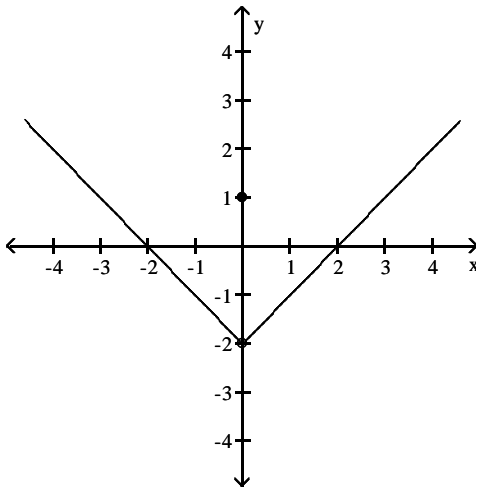

- A) -2 B) 0 C) 1 D) does not exist

33) $\lim_{x \rightarrow 0} f(x)$

33) _____

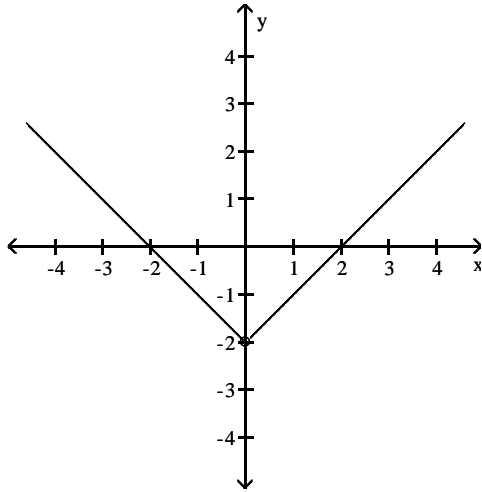

- A) -2 B) -1 C) does not exist D) 2

34) Find $\lim_{x \rightarrow (-1)^-} f(x)$ and $\lim_{x \rightarrow (-1)^+} f(x)$

34) _____

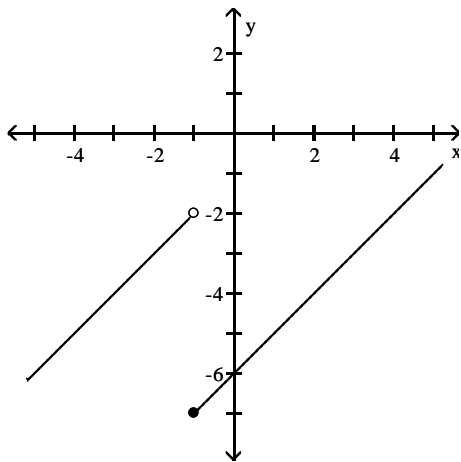

- A) -7; -5 B) -7; -2 C) -5; -2 D) -2; -7

Use the table of values of f to estimate the limit.

35) Let $f(x) = x^2 + 8x - 2$, find $\lim_{x \rightarrow 2} f(x)$.

35) _____

x	1.9	1.99	1.999	2.001	2.01	2.1
$f(x)$						

A)

x	1.9	1.99	1.999	2.001	2.01	2.1
$f(x)$	5.043	5.364	5.396	5.404	5.436	5.763

; limit = ∞

B)

x	1.9	1.99	1.999	2.001	2.01	2.1
$f(x)$	5.043	5.364	5.396	5.404	5.436	5.763

; limit = 5.40

C)

x	1.9	1.99	1.999	2.001	2.01	2.1
$f(x)$	16.692	17.592	17.689	17.710	17.808	18.789

; limit = 17.70

D)

x	1.9	1.99	1.999	2.001	2.01	2.1
$f(x)$	16.810	17.880	17.988	18.012	18.120	19.210

; limit = 18.0

36) Let $f(x) = \frac{x-4}{\sqrt{x}-2}$, find $\lim_{x \rightarrow 4} f(x)$.

36) _____

x	3.9	3.99	3.999	4.001	4.01	4.1
$f(x)$						

A)

x	3.9	3.99	3.999	4.001	4.01	4.1
$f(x)$	1.19245	1.19925	1.19993	1.20007	1.20075	1.20745

; limit = ∞

B)

x	3.9	3.99	3.999	4.001	4.01	4.1
$f(x)$	1.19245	1.19925	1.19993	1.20007	1.20075	1.20745

; limit = 1.20

C)

x	3.9	3.99	3.999	4.001	4.01	4.1
$f(x)$	3.97484	3.99750	3.99975	4.00025	4.00250	4.02485

; limit = 4.0

D)

x	3.9	3.99	3.999	4.001	4.01	4.1
$f(x)$	5.07736	5.09775	5.09978	5.10022	5.10225	5.12236

; limit = 5.10

37) Let $f(x) = x^2 - 5$, find $\lim_{x \rightarrow 0} f(x)$.

37) _____

x	-0.1	-0.01	-0.001	0.001	0.01	0.1
f(x)						

A)

x	-0.1	-0.01	-0.001	0.001	0.01	0.1
f(x)	-1.4970	-1.4999	-1.5000	-1.5000	-1.4999	-1.4970

; limit = ∞

B)

x	-0.1	-0.01	-0.001	0.001	0.01	0.1
f(x)	-2.9910	-2.9999	-3.0000	-3.0000	-2.9999	-2.9910

; limit = -3.0

C)

x	-0.1	-0.01	-0.001	0.001	0.01	0.1
f(x)	-4.9900	-4.9999	-5.0000	-5.0000	-4.9999	-4.9900

; limit = -5.0

D)

x	-0.1	-0.01	-0.001	0.001	0.01	0.1
f(x)	-1.4970	-1.4999	-1.5000	-1.5000	-1.4999	-1.4970

; limit = -15.0

38) Let $f(x) = \frac{x-4}{x^2-5x+4}$, find $\lim_{x \rightarrow 4} f(x)$.

38) _____

x	3.9	3.99	3.999	4.001	4.01	4.1
f(x)						

A)

x	3.9	3.99	3.999	4.001	4.01	4.1
f(x)	0.4448	0.4344	0.4334	0.4332	0.4322	0.4226

; limit = 0.4333

B)

x	3.9	3.99	3.999	4.001	4.01	4.1
f(x)	-0.3448	-0.3344	-0.3334	-0.3332	-0.3322	-0.3226

; limit = -0.3333

C)

x	3.9	3.99	3.999	4.001	4.01	4.1
f(x)	0.3448	0.3344	0.3334	0.3332	0.3322	0.3226

; limit = 0.3333

D)

x	3.9	3.99	3.999	4.001	4.01	4.1
f(x)	0.2448	0.2344	0.2334	0.2332	0.2322	0.2226

; limit = 0.2333

39) Let $f(x) = \frac{x^2 - 7x + 10}{x^2 - 9x + 20}$, find $\lim_{x \rightarrow 5} f(x)$.

39) _____

x	4.9	4.99	4.999	5.001	5.01	5.1
f(x)						

A)

x	4.9	4.99	4.999	5.001	5.01	5.1
f(x)	3.1222	2.9202	2.9020	2.8980	2.8802	2.7182

; limit = 2.9

B)

x	4.9	4.99	4.999	5.001	5.01	5.1
f(x)	0.7802	0.7780	0.7778	0.7778	0.7775	0.7753

; limit = 0.7778

C)

x	4.9	4.99	4.999	5.001	5.01	5.1
f(x)	3.2222	3.0202	3.0020	2.9980	2.9802	2.8182

; limit = 3

D)

x	4.9	4.99	4.999	5.001	5.01	5.1
f(x)	3.3222	3.1202	3.1020	3.0980	3.0802	2.9182

; limit = 3.1

40) Let $f(x) = \frac{\sin(6x)}{x}$, find $\lim_{x \rightarrow 0} f(x)$.

40) _____

x	-0.1	-0.01	-0.001	0.001	0.01	0.1
f(x)		5.99640065			5.99640065	

- A) limit = 5.5
C) limit = 0

- B) limit = 6
D) limit does not exist

41) Let $f(\theta) = \frac{\cos(5\theta)}{\theta}$, find $\lim_{\theta \rightarrow 0} f(\theta)$.

41) _____

x	-0.1	-0.01	-0.001	0.001	0.01	0.1
f(θ)	-8.7758256					8.7758256

- A) limit = 8.7758256
C) limit does not exist

- B) limit = 0
D) limit = 5

SHORT ANSWER. Write the word or phrase that best completes each statement or answers the question.

Provide an appropriate response.

42) It can be shown that the inequalities $1 - \frac{x^2}{6} < \frac{x \sin(x)}{2 - 2 \cos(x)} < 1$ hold for all values of x close

42) _____

to zero. What, if anything, does this tell you about $\frac{x \sin(x)}{2 - 2 \cos(x)}$? Explain.

MULTIPLE CHOICE. Choose the one alternative that best completes the statement or answers the question.

43) Write the formal notation for the principle "the limit of a quotient is the quotient of the limits" and include a statement of any restrictions on the principle. 43) _____

A) If $\lim_{x \rightarrow a} g(x) = M$ and $\lim_{x \rightarrow a} f(x) = L$, then $\lim_{x \rightarrow a} \frac{g(x)}{f(x)} = \frac{\lim_{x \rightarrow a} g(x)}{\lim_{x \rightarrow a} f(x)} = \frac{M}{L}$, provided that

$f(a) \neq 0$.

B) $\lim_{x \rightarrow a} \frac{g(x)}{f(x)} = \frac{g(a)}{f(a)}$.

C) $\lim_{x \rightarrow a} \frac{g(x)}{f(x)} = \frac{g(a)}{f(a)}$, provided that $f(a) \neq 0$.

D) If $\lim_{x \rightarrow a} g(x) = M$ and $\lim_{x \rightarrow a} f(x) = L$, then $\lim_{x \rightarrow a} \frac{g(x)}{f(x)} = \frac{\lim_{x \rightarrow a} g(x)}{\lim_{x \rightarrow a} f(x)} = \frac{M}{L}$, provided that $L \neq 0$.

44) Provide a short sentence that summarizes the general limit principle given by the formal notation $\lim_{x \rightarrow a} [f(x) \pm g(x)] = \lim_{x \rightarrow a} f(x) \pm \lim_{x \rightarrow a} g(x) = L \pm M$, given that $\lim_{x \rightarrow a} f(x) = L$ and $\lim_{x \rightarrow a} g(x) = M$. 44) _____

A) The limit of a sum or a difference is the sum or the difference of the limits.

B) The sum or the difference of two functions is the sum of two limits.

C) The limit of a sum or a difference is the sum or the difference of the functions.

D) The sum or the difference of two functions is continuous.

45) The statement "the limit of a constant times a function is the constant times the limit" follows from a combination of two fundamental limit principles. What are they? 45) _____

A) The limit of a function is a constant times a limit, and the limit of a constant is the constant.

B) The limit of a product is the product of the limits, and a constant is continuous.

C) The limit of a product is the product of the limits, and the limit of a quotient is the quotient of the limits.

D) The limit of a constant is the constant, and the limit of a product is the product of the limits.

Find the limit.

46) $\lim_{x \rightarrow 7} \sqrt{3}$ 46) _____

A) $\sqrt{3}$

B) 7

C) $\sqrt{7}$

D) 3

47) $\lim_{x \rightarrow -4} (6x - 1)$ 47) _____

A) 23

B) -23

C) -25

D) 25

48) $\lim_{x \rightarrow -14} (20 - 6x)$ 48) _____

A) -64

B) 104

C) 64

D) -104

Give an appropriate answer.

49) Let $\lim_{x \rightarrow 6} f(x) = 4$ and $\lim_{x \rightarrow 6} g(x) = 5$. Find $\lim_{x \rightarrow 6} [f(x) - g(x)]$. 49) _____

- A) 4 B) -1 C) 6 D) 9

50) Let $\lim_{x \rightarrow 1} f(x) = -1$ and $\lim_{x \rightarrow 1} g(x) = -6$. Find $\lim_{x \rightarrow 1} [f(x) \cdot g(x)]$. 50) _____

- A) -7 B) -6 C) 1 D) 6

51) Let $\lim_{x \rightarrow -3} f(x) = 10$ and $\lim_{x \rightarrow -3} g(x) = 4$. Find $\lim_{x \rightarrow -3} \frac{f(x)}{g(x)}$. 51) _____

- A) -3 B) $\frac{2}{5}$ C) $\frac{5}{2}$ D) 6

52) Let $\lim_{x \rightarrow 5} f(x) = 225$. Find $\lim_{x \rightarrow 5} \sqrt{f(x)}$. 52) _____

- A) 225 B) 3.8730 C) 5 D) 15

53) Let $\lim_{x \rightarrow 4} f(x) = -4$ and $\lim_{x \rightarrow 4} g(x) = 2$. Find $\lim_{x \rightarrow 4} [f(x) + g(x)]^2$. 53) _____

- A) -6 B) 20 C) -2 D) 4

54) Let $\lim_{x \rightarrow 8} f(x) = 81$. Find $\lim_{x \rightarrow 8} \sqrt[4]{f(x)}$. 54) _____

- A) 8 B) 81 C) 3 D) 4

55) Let $\lim_{x \rightarrow 10} f(x) = -9$ and $\lim_{x \rightarrow 10} g(x) = 5$. Find $\lim_{x \rightarrow 10} \left[\frac{8f(x) - 3g(x)}{10 + g(x)} \right]$. 55) _____

- A) 10 B) $-\frac{29}{5}$ C) $-\frac{51}{5}$ D) $-\frac{19}{5}$

Find the limit.

56) $\lim_{x \rightarrow 2} (x^3 + 5x^2 - 7x + 1)$ 56) _____

- A) 15 B) 0 C) 29 D) does not exist

57) $\lim_{x \rightarrow 2} (2x^5 - 2x^4 + 4x^3 + x^2 + 5)$ 57) _____

- A) 41 B) 137 C) 73 D) 9

58) $\lim_{x \rightarrow -1} \frac{x}{3x + 2}$ 58) _____

- A) does not exist B) 0 C) 1 D) $-\frac{1}{5}$

- 59) $\lim_{x \rightarrow 0} \frac{x^3 - 6x + 8}{x - 2}$ 59) _____
 A) 0 B) Does not exist C) 4 D) -4
- 60) $\lim_{x \rightarrow 1} \frac{3x^2 + 7x - 2}{3x^2 - 4x - 2}$ 60) _____
 A) 0 B) $-\frac{8}{3}$ C) $-\frac{7}{4}$ D) Does not exist
- 61) $\lim_{x \rightarrow 1} (x + 2)^2(x - 3)^3$ 61) _____
 A) 64 B) -8 C) -72 D) 576
- 62) $\lim_{x \rightarrow 7} \sqrt{x^2 + 2x + 1}$ 62) _____
 A) 8 B) 64 C) ± 8 D) does not exist
- 63) $\lim_{x \rightarrow 1} \sqrt{10x + 15}$ 63) _____
 A) -25 B) -5 C) 25 D) 5
- 64) $\lim_{h \rightarrow 0} \frac{2}{\sqrt{3h + 4} + 2}$ 64) _____
 A) 2 B) Does not exist C) 1/2 D) 1
- 65) $\lim_{x \rightarrow 0} \frac{\sqrt{1+x} - 1}{x}$ 65) _____
 A) 0 B) 1/2 C) Does not exist D) 1/4

Determine the limit by sketching an appropriate graph.

- 66) $\lim_{x \rightarrow 5^-} f(x)$, where $f(x) = \begin{cases} -4x + 2 & \text{for } x < 5 \\ 2x + 3 & \text{for } x \geq 5 \end{cases}$ 66) _____
 A) -18 B) 4 C) 13 D) 3
- 67) $\lim_{x \rightarrow 2^+} f(x)$, where $f(x) = \begin{cases} -5x - 3 & \text{for } x < 2 \\ 3x - 2 & \text{for } x \geq 2 \end{cases}$ 67) _____
 A) -2 B) -1 C) -13 D) 4
- 68) $\lim_{x \rightarrow -4^+} f(x)$, where $f(x) = \begin{cases} x^2 + 2 & \text{for } x \neq -4 \\ 0 & \text{for } x = -4 \end{cases}$ 68) _____
 A) 14 B) 0 C) 16 D) 18

69) $\lim_{x \rightarrow 5^-} f(x)$, where $f(x) = \begin{cases} \sqrt{9-x^2} & 0 \leq x < 3 \\ 3 & 3 \leq x < 5 \\ 5 & x = 5 \end{cases}$ 69) _____

A) 5 B) Does not exist C) 0 D) 3

70) $\lim_{x \rightarrow -7^+} f(x)$, where $f(x) = \begin{cases} 3x & -7 \leq x < 0, \text{ or } 0 < x \leq 3 \\ 3 & x = 0 \\ 0 & x < -7 \text{ or } x > 3 \end{cases}$ 70) _____

A) 7 B) -0 C) -21 D) Does not exist

Find the limit, if it exists.

71) $\lim_{x \rightarrow 0} \frac{x^3 + 12x^2 - 5x}{5x}$ 71) _____

A) Does not exist B) 5 C) -1 D) 0

72) $\lim_{x \rightarrow 1} \frac{x^4 - 1}{x - 1}$ 72) _____

A) Does not exist B) 4 C) 0 D) 2

73) $\lim_{x \rightarrow 10} \frac{x^2 - 100}{x - 10}$ 73) _____

A) 1 B) 20 C) 10 D) Does not exist

74) $\lim_{x \rightarrow -4} \frac{x^2 + 7x + 12}{x + 4}$ 74) _____

A) -1 B) 56 C) Does not exist D) 7

75) $\lim_{x \rightarrow 4} \frac{x^2 + 4x - 32}{x - 4}$ 75) _____

A) Does not exist B) 0 C) 4 D) 12

76) $\lim_{x \rightarrow 5} \frac{x^2 + 2x - 35}{x^2 - 25}$ 76) _____

A) $-\frac{1}{5}$ B) Does not exist C) 0 D) $\frac{6}{5}$

77) $\lim_{x \rightarrow 4} \frac{x^2 - 16}{x^2 - 6x + 8}$ 77) _____

A) 0 B) Does not exist C) 2 D) 4

78) $\lim_{x \rightarrow -1} \frac{x^2 - 6x - 7}{x^2 - 2x - 3}$ 78) _____

A) -2 B) Does not exist C) 2 D) $-\frac{3}{2}$

- 79) $\lim_{h \rightarrow 0} \frac{(x+h)^3 - x^3}{h}$ 79) _____
 A) $3x^2 + 3xh + h^2$ B) 0 C) $3x^2$ D) Does not exist
- 80) $\lim_{x \rightarrow 7} \frac{|7-x|}{7-x}$ 80) _____
 A) Does not exist B) 1 C) 0 D) -1

Provide an appropriate response.

- 81) It can be shown that the inequalities $-x \leq x \cos\left(\frac{1}{x}\right) \leq x$ hold for all values of $x \geq 0$. 81) _____
 Find $\lim_{x \rightarrow 0} x \cos\left(\frac{1}{x}\right)$ if it exists.
 A) 0 B) 1 C) does not exist D) 0.0007
- 82) The inequality $1 - \frac{x^2}{2} < \frac{\sin x}{x} < 1$ holds when x is measured in radians and $|x| < 1$. 82) _____
 Find $\lim_{x \rightarrow 0} \frac{\sin x}{x}$ if it exists.
 A) 0.0007 B) 1 C) 0 D) does not exist
- 83) If $x^3 \leq f(x) \leq x$ for x in $[-1,1]$, find $\lim_{x \rightarrow 0} f(x)$ if it exists. 83) _____
 A) -1 B) 0 C) 1 D) does not exist

Compute the values of $f(x)$ and use them to determine the indicated limit.

- 84) If $f(x) = x^2 + 8x - 2$, find $\lim_{x \rightarrow 2} f(x)$. 84) _____

x	1.9	1.99	1.999	2.001	2.01	2.1
$f(x)$						

- A)

x	1.9	1.99	1.999	2.001	2.01	2.1
$f(x)$	5.043	5.364	5.396	5.404	5.436	5.763

; limit = 5.40
- B)

x	1.9	1.99	1.999	2.001	2.01	2.1
$f(x)$	5.043	5.364	5.396	5.404	5.436	5.763

; limit = ∞
- C)

x	1.9	1.99	1.999	2.001	2.01	2.1
$f(x)$	16.692	17.592	17.689	17.710	17.808	18.789

; limit = 17.70
- D)

x	1.9	1.99	1.999	2.001	2.01	2.1
$f(x)$	16.810	17.880	17.988	18.012	18.120	19.210

; limit = 18.0

85) If $f(x) = \frac{x^4 - 1}{x - 1}$, find $\lim_{x \rightarrow 1} f(x)$.

85) _____

x	0.9	0.99	0.999	1.001	1.01	1.1
f(x)						

A)

x	0.9	0.99	0.999	1.001	1.01	1.1
f(x)	1.032	1.182	1.198	1.201	1.218	1.392

; limit = ∞

B)

x	0.9	0.99	0.999	1.001	1.01	1.1
f(x)	3.439	3.940	3.994	4.006	4.060	4.641

; limit = 4.0

C)

x	0.9	0.99	0.999	1.001	1.01	1.1
f(x)	1.032	1.182	1.198	1.201	1.218	1.392

; limit = 1.210

D)

x	0.9	0.99	0.999	1.001	1.01	1.1
f(x)	4.595	5.046	5.095	5.105	5.154	5.677

; limit = 5.10

86) If $f(x) = \frac{x^3 - 6x + 8}{x - 2}$, find $\lim_{x \rightarrow 0} f(x)$.

86) _____

x	-0.1	-0.01	-0.001	0.001	0.01	0.1
f(x)						

A)

x	-0.1	-0.01	-0.001	0.001	0.01	0.1
f(x)	-1.22843	-1.20298	-1.20030	-1.19970	-1.19699	-1.16858

; limit = -1.20

B)

x	-0.1	-0.01	-0.001	0.001	0.01	0.1
f(x)	-1.22843	-1.20298	-1.20030	-1.19970	-1.19699	-1.16858

; limit = ∞

C)

x	-0.1	-0.01	-0.001	0.001	0.01	0.1
f(x)	-4.09476	-4.00995	-4.00100	-3.99900	-3.98995	-3.89526

; limit = -4.0

D)

x	-0.1	-0.01	-0.001	0.001	0.01	0.1
f(x)	-2.18529	-2.10895	-2.10090	-2.99910	-2.09096	-2.00574

; limit = -2.10

87) If $f(x) = \frac{x-4}{\sqrt{x}-2}$, find $\lim_{x \rightarrow 4} f(x)$.

87) _____

x	3.9	3.99	3.999	4.001	4.01	4.1
f(x)						

A)

x	3.9	3.99	3.999	4.001	4.01	4.1	
f(x)	1.19245	1.19925	1.19993	1.20007	1.20075	1.20745	; limit = 1.20

B)

x	3.9	3.99	3.999	4.001	4.01	4.1	
f(x)	3.97484	3.99750	3.99975	4.00025	4.00250	4.02485	; limit = 4.0

C)

x	3.9	3.99	3.999	4.001	4.01	4.1	
f(x)	5.07736	5.09775	5.09978	5.10022	5.10225	5.12236	; limit = 5.10

D)

x	3.9	3.99	3.999	4.001	4.01	4.1	
f(x)	1.19245	1.19925	1.19993	1.20007	1.20075	1.20745	; limit = ∞

88) If $f(x) = x^2 - 5$, find $\lim_{x \rightarrow 0} f(x)$.

88) _____

x	-0.1	-0.01	-0.001	0.001	0.01	0.1
f(x)						

A)

x	-0.1	-0.01	-0.001	0.001	0.01	0.1	
f(x)	-1.4970	-1.4999	-1.5000	-1.5000	-1.4999	-1.4970	; limit = ∞

B)

x	-0.1	-0.01	-0.001	0.001	0.01	0.1	
f(x)	-2.9910	-2.9999	-3.0000	-3.0000	-2.9999	-2.9910	; limit = -3.0

C)

x	-0.1	-0.01	-0.001	0.001	0.01	0.1	
f(x)	-1.4970	-1.4999	-1.5000	-1.5000	-1.4999	-1.4970	; limit = -15.0

D)

x	-0.1	-0.01	-0.001	0.001	0.01	0.1	
f(x)	-4.9900	-4.9999	-5.0000	-5.0000	-4.9999	-4.9900	; limit = -5.0

89) If $f(x) = \frac{\sqrt{x+1}}{x+1}$, find $\lim_{x \rightarrow 1} f(x)$.

89) _____

x	0.9	0.99	0.999	1.001	1.01	1.1
f(x)						

A)

x	0.9	0.99	0.999	1.001	1.01	1.1
f(x)	0.21764	0.21266	0.21219	0.21208	0.21160	0.20702

; limit = ∞

B)

x	0.9	0.99	0.999	1.001	1.01	1.1
f(x)	0.72548	0.70888	0.70728	0.70693	0.70535	0.69007

; limit = 0.7071

C)

x	0.9	0.99	0.999	1.001	1.01	1.1
f(x)	0.21764	0.21266	0.21219	0.21208	0.21160	0.20702

; limit = 0.21213

D)

x	0.9	0.99	0.999	1.001	1.01	1.1
f(x)	2.15293	2.13799	2.13656	2.13624	2.13481	2.12106

; limit = 2.13640

90) If $f(x) = \sqrt{x} - 2$, find $\lim_{x \rightarrow 4} f(x)$.

90) _____

x	3.9	3.99	3.999	4.001	4.01	4.1
f(x)						

A)

x	3.9	3.99	3.999	4.001	4.01	4.1
f(x)	3.9000	2.9000	1.9000	2.0000	3.0000	4.0000

; limit = ∞

B)

x	3.9	3.99	3.999	4.001	4.01	4.1
f(x)	1.47736	1.49775	1.49977	1.50022	1.50225	1.52236

; limit = 1.50

C)

x	3.9	3.99	3.999	4.001	4.01	4.1
f(x)	-0.02516	-0.00250	-0.00025	0.00025	0.00250	0.02485

; limit = 0

D)

x	3.9	3.99	3.999	4.001	4.01	4.1
f(x)	3.9000	2.9000	1.9000	2.0000	3.0000	4.0000

; limit = 1.95

For the function f whose graph is given, determine the limit.

91) Find $\lim_{x \rightarrow 4^-} f(x)$ and $\lim_{x \rightarrow 4^+} f(x)$.

91) _____

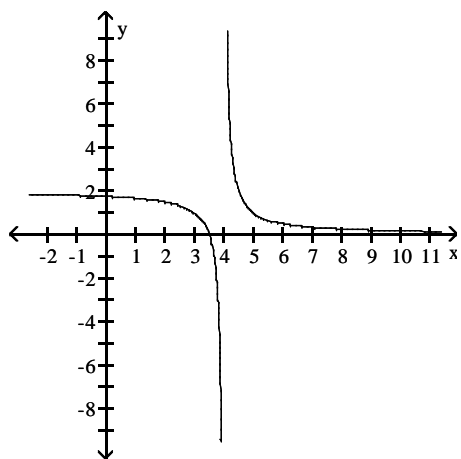

A) $\infty, -\infty$

B) $-\infty, \infty$

C) 4; 4

D) -4, 4

92) Find $\lim_{x \rightarrow 3^-} f(x)$ and $\lim_{x \rightarrow 3^+} f(x)$.

92) _____

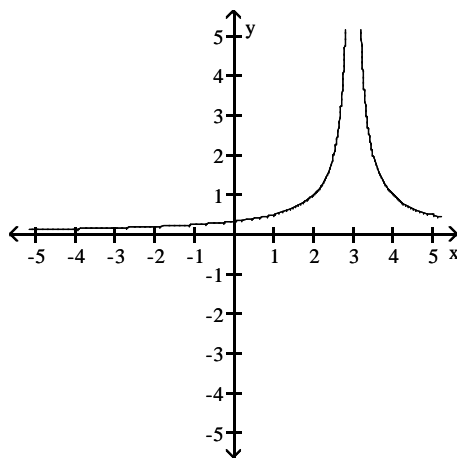

A) 3; -3

B) 0; 1

C) $\infty; \infty$

D) $-\infty; \infty$

93) Find $\lim_{x \rightarrow 3} f(x)$.

93) _____

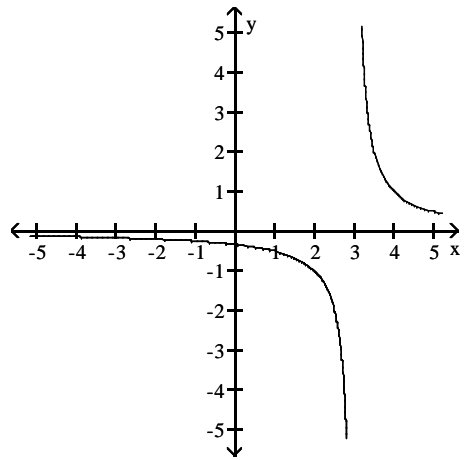

- A) $-\infty$ B) 3 C) ∞ D) does not exist

94) Find $\lim_{x \rightarrow -4} f(x)$.

94) _____

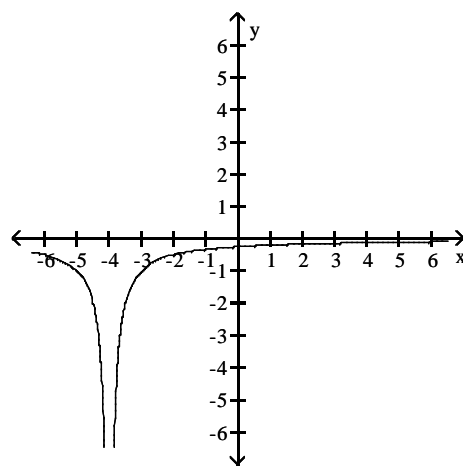

- A) ∞ B) 0 C) -4 D) $-\infty$

95) Find $\lim_{x \rightarrow 0} f(x)$.

95) _____

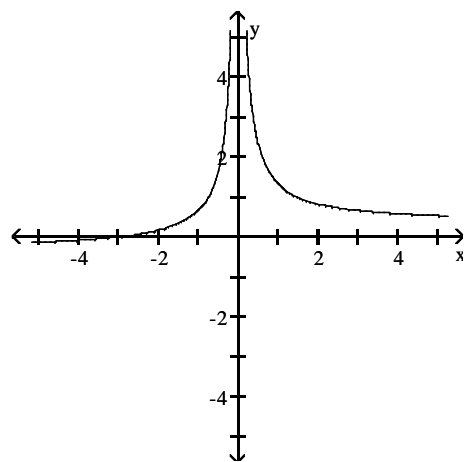

- A) ∞ B) 0 C) 1 D) $-\infty$

Find the limit.

- 96) $\lim_{x \rightarrow -2} \frac{1}{x+2}$ 96) _____
A) ∞ B) 1/2 C) Does not exist D) $-\infty$
- 97) $\lim_{x \rightarrow -9^+} \frac{1}{x+9}$ 97) _____
A) 0 B) ∞ C) $-\infty$ D) -1
- 98) $\lim_{x \rightarrow 7^+} \frac{1}{(x-7)^2}$ 98) _____
A) -1 B) ∞ C) $-\infty$ D) 0
- 99) $\lim_{x \rightarrow -5^-} \frac{6}{x^2 - 25}$ 99) _____
A) 0 B) -1 C) ∞ D) $-\infty$
- 100) $\lim_{x \rightarrow 5^+} \frac{1}{x^2 - 25}$ 100) _____
A) $-\infty$ B) ∞ C) 1 D) 0
- 101) $\lim_{x \rightarrow (\pi/2)^+} \tan x$ 101) _____
A) 0 B) ∞ C) 1 D) $-\infty$
- 102) $\lim_{x \rightarrow (-\pi/2)^-} \sec x$ 102) _____
A) 1 B) $-\infty$ C) 0 D) ∞
- 103) $\lim_{x \rightarrow 0^+} (1 + \csc x)$ 103) _____
A) ∞ B) 1 C) 0 D) Does not exist
- 104) $\lim_{x \rightarrow 0} (1 - \cot x)$ 104) _____
A) ∞ B) 0 C) $-\infty$ D) Does not exist
- 105) $\lim_{x \rightarrow -2^+} \frac{x^2 - 6x + 8}{x^3 - 4x}$ 105) _____
A) ∞ B) $-\infty$ C) Does not exist D) 0
- 106) $\lim_{x \rightarrow 0} \frac{x^2 - 3x + 2}{x^3 - x}$ 106) _____
A) ∞ B) $-\infty$ C) 2 D) Does not exist

Find all vertical asymptotes of the given function.

107) $g(x) = \frac{9x}{x+4}$ 107) _____

- A) none B) $x = -4$ C) $x = 4$ D) $x = 9$

108) $f(x) = \frac{x+9}{x^2-36}$ 108) _____

- A) $x = 0, x = 36$ B) $x = -6, x = 6$
 C) $x = 36, x = -9$ D) $x = -6, x = 6, x = -9$

109) $g(x) = \frac{x+9}{x^2+25}$ 109) _____

- A) $x = -5, x = -9$ B) $x = -5, x = 5$
 C) $x = -5, x = 5, x = -9$ D) none

110) $h(x) = \frac{x+11}{x^2-36x}$ 110) _____

- A) $x = -6, x = 6$ B) $x = 0, x = 36$
 C) $x = 36, x = -11$ D) $x = 0, x = -6, x = 6$

111) $f(x) = \frac{x-1}{x^3+36x}$ 111) _____

- A) $x = 0, x = -6, x = 6$ B) $x = 0, x = -36$
 C) $x = 0$ D) $x = -6, x = 6$

112) $R(x) = \frac{-3x^2}{x^2+4x-77}$ 112) _____

- A) $x = -11, x = 7$ B) $x = -77$
 C) $x = 11, x = -7$ D) $x = -11, x = 7, x = -3$

113) $R(x) = \frac{x-1}{x^3+2x^2-80x}$ 113) _____

- A) $x = -8, x = -30, x = 10$ B) $x = -8, x = 0, x = 10$
 C) $x = -10, x = 8$ D) $x = -10, x = 0, x = 8$

114) $f(x) = \frac{-2x(x+2)}{2x^2-5x-7}$ 114) _____

- A) $x = \frac{7}{2}, x = -1$ B) $x = \frac{2}{7}, x = -1$ C) $x = -\frac{7}{2}, x = 1$ D) $x = -\frac{2}{7}, x = 1$

115) $f(x) = \frac{x-5}{25x-x^3}$ 115) _____

- A) $x = -5, x = 5$ B) $x = 0, x = -5, x = 5$
 C) $x = 0, x = 5$ D) $x = 0, x = -5$

$$116) f(x) = \frac{-x^2 + 16}{x^2 + 5x + 4}$$

A) $x = -1, x = -4$

B) $x = -1$

C) $x = 1, x = -4$

D) $x = -1, x = 4$

116) _____

Choose the graph that represents the given function without using a graphing utility.

$$117) f(x) = \frac{x}{x+1}$$

A)

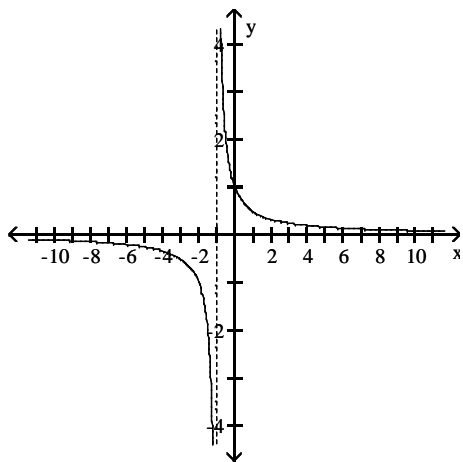

B)

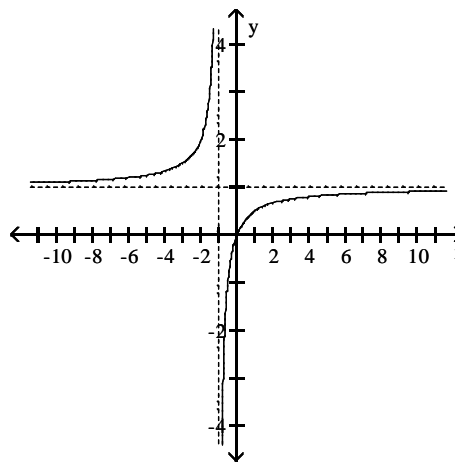

C)

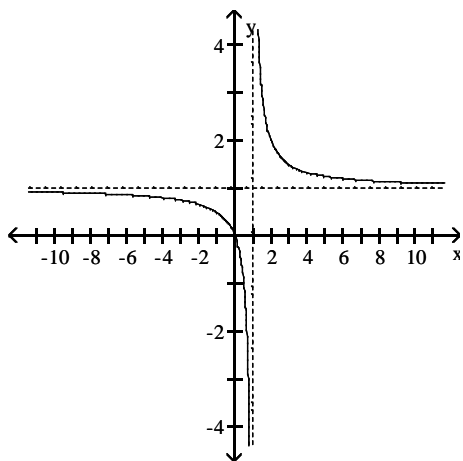

D)

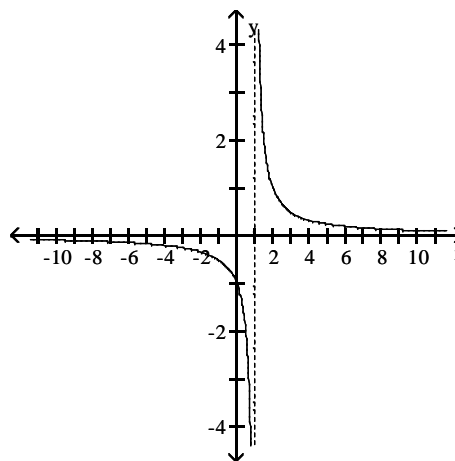

117) _____

118) $f(x) = \frac{x}{x^2 + x + 4}$

118) _____

A)

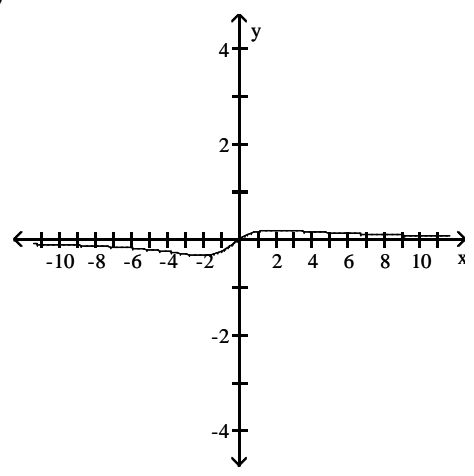

B)

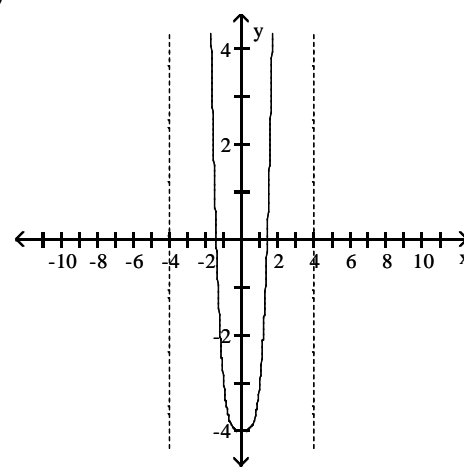

C)

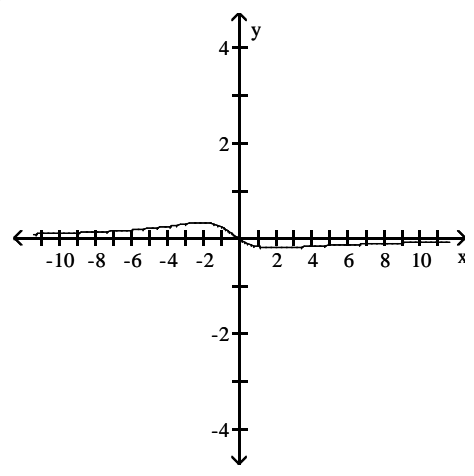

D)

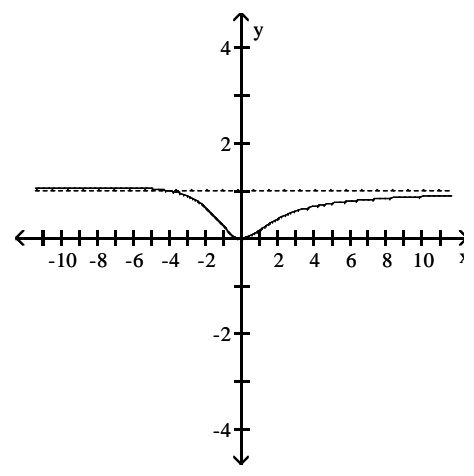

119) $f(x) = \frac{x^2 - 3}{x^3}$

119) _____

A)

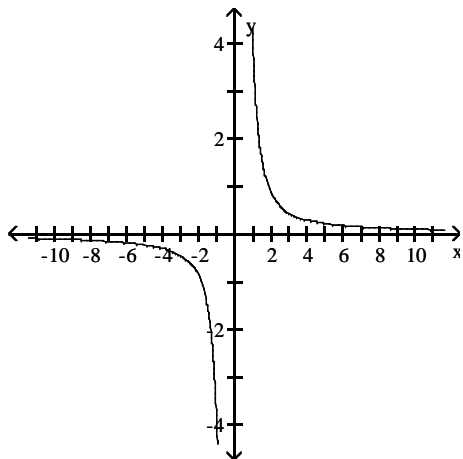

B)

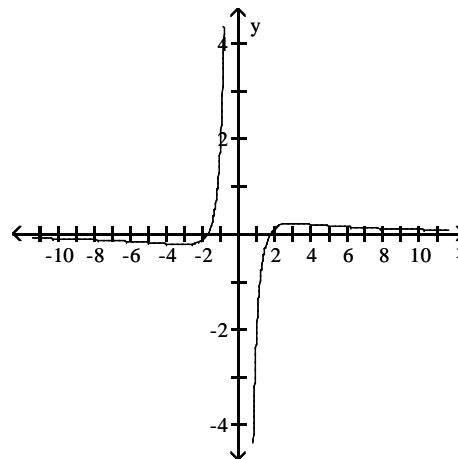

C)

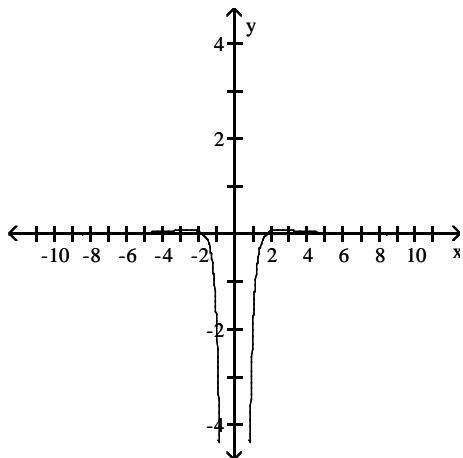

D)

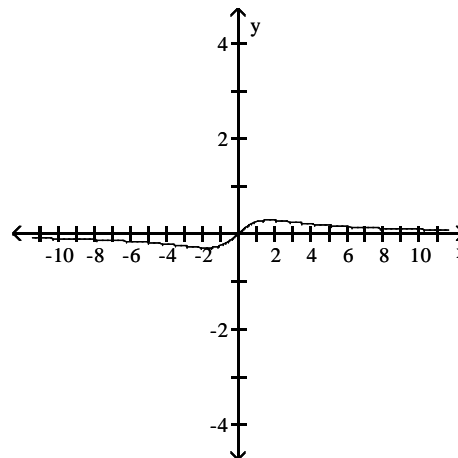

120) $f(x) = \frac{1}{x+1}$

120) _____

A)

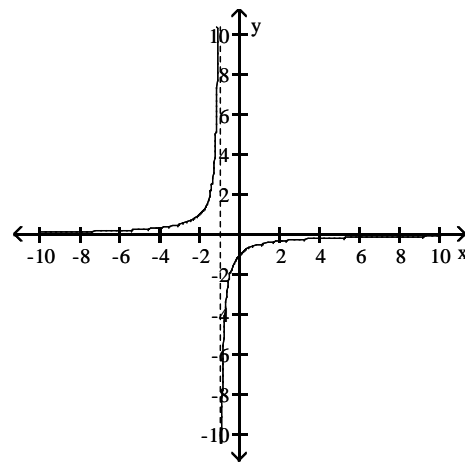

B)

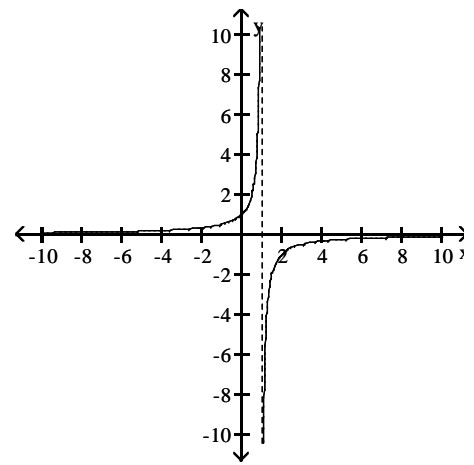

C)

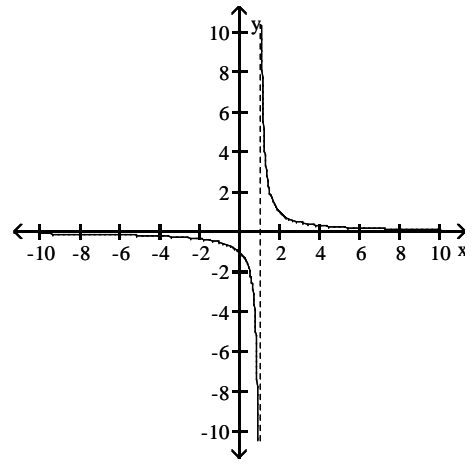

D)

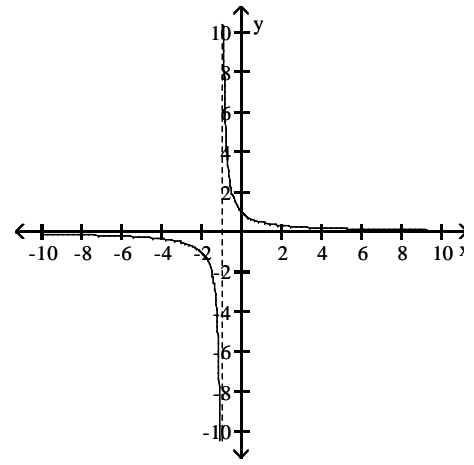

121) $f(x) = \frac{x-1}{x+1}$

121) _____

A)

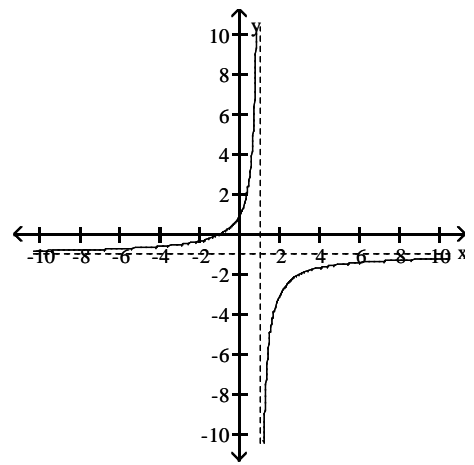

B)

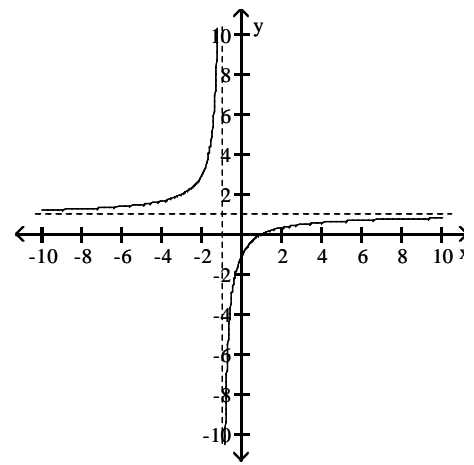

C)

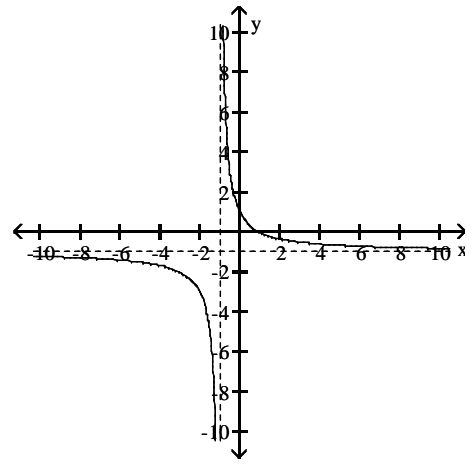

D)

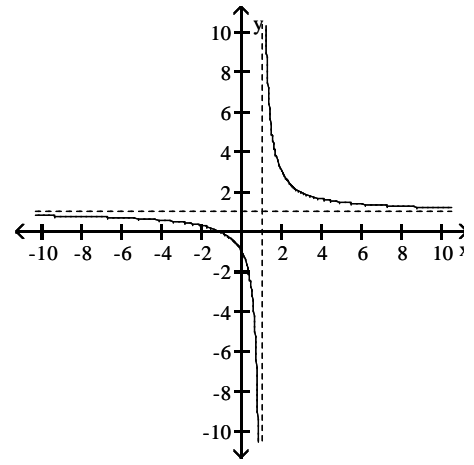

122) $f(x) = \frac{1}{(x+2)^2}$

122) _____

A)

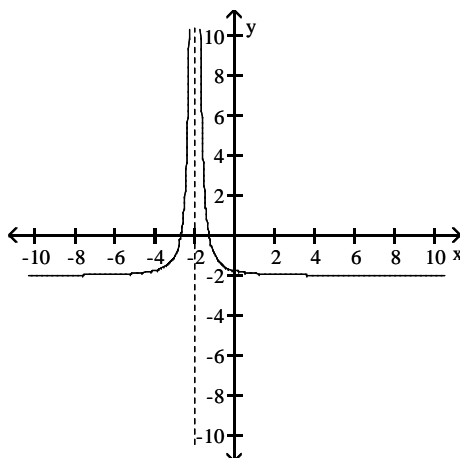

B)

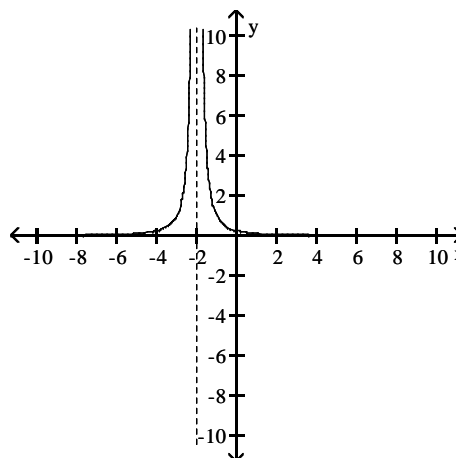

C)

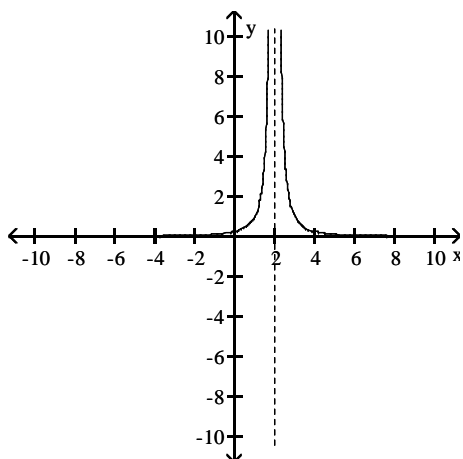

D)

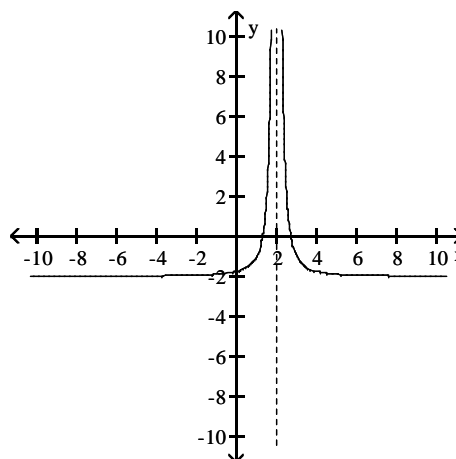

123) $f(x) = \frac{2x^2}{4 - x^2}$

123) _____

A)

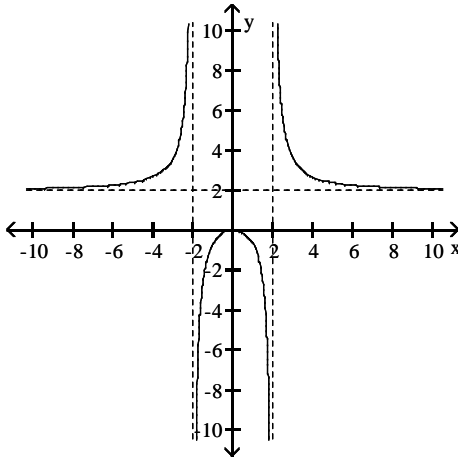

B)

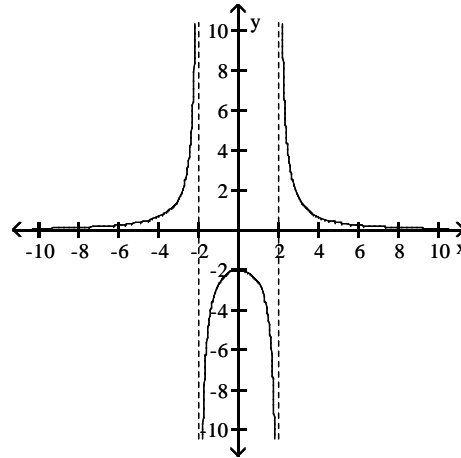

C)

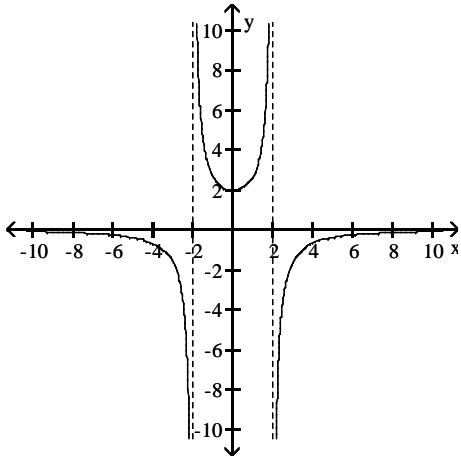

D)

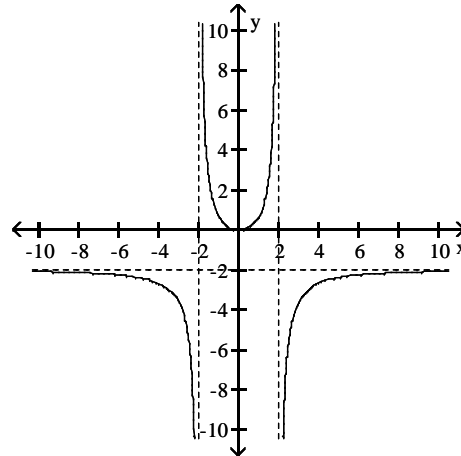

Find the limit.

124) $\lim_{x \rightarrow \infty} \frac{3}{x} - 7$

124) _____

A) -10

B) -4

C) 7

D) -7

125) $\lim_{x \rightarrow -\infty} \frac{8}{8 - (1/x^2)}$

125) _____

A) $\frac{8}{7}$

B) 1

C) $-\infty$

D) 8

126) $\lim_{x \rightarrow -\infty} \frac{-7 + (6/x)}{7 - (1/x^2)}$

126) _____

A) 1

B) ∞

C) $-\infty$

D) -1

127) $\lim_{x \rightarrow \infty} \frac{x^2 + 7x + 3}{x^3 + 6x^2 + 4}$ 127) _____
 A) ∞ B) 1 C) 0 D) $\frac{3}{4}$

128) $\lim_{x \rightarrow -\infty} \frac{-12x^2 - 7x + 15}{-16x^2 + 3x + 7}$ 128) _____
 A) 1 B) $\frac{15}{7}$ C) ∞ D) $\frac{3}{4}$

129) $\lim_{x \rightarrow \infty} \frac{5x + 1}{16x - 7}$ 129) _____
 A) $\frac{5}{16}$ B) $-\frac{1}{7}$ C) ∞ D) 0

130) $\lim_{x \rightarrow \infty} \frac{8x^3 - 4x^2 + 3x}{-x^3 - 2x + 5}$ 130) _____
 A) ∞ B) -8 C) $\frac{3}{2}$ D) 8

131) $\lim_{x \rightarrow -\infty} \frac{3x^3 + 4x^2}{x - 5x^2}$ 131) _____
 A) ∞ B) 3 C) $-\infty$ D) $-\frac{4}{5}$

132) $\lim_{x \rightarrow -\infty} \frac{\cos 5x}{x}$ 132) _____
 A) $-\infty$ B) 1 C) 5 D) 0

Divide numerator and denominator by the highest power of x in the denominator to find the limit.

133) $\lim_{x \rightarrow \infty} \sqrt{\frac{25x^2}{6 + 9x^2}}$ 133) _____
 A) $\frac{25}{6}$ B) $\frac{25}{9}$ C) $\frac{5}{3}$ D) does not exist

134) $\lim_{x \rightarrow \infty} \sqrt{\frac{25x^2 + x - 3}{(x - 11)(x + 1)}}$ 134) _____
 A) 25 B) 5 C) ∞ D) 0

135) $\lim_{x \rightarrow \infty} \frac{-5\sqrt{x} + x^{-1}}{-4x - 5}$ 135) _____
 A) ∞ B) 0 C) $\frac{5}{4}$ D) $\frac{1}{-4}$

136) $\lim_{x \rightarrow \infty} \frac{-3x^{-1} - 2x^{-3}}{-2x^{-2} + x^{-5}}$ 136) _____
 A) $-\infty$ B) 0 C) $\frac{3}{2}$ D) ∞

137) $\lim_{x \rightarrow \infty} \frac{\sqrt[3]{x} + 6x - 5}{2x + x^{2/3} - 7}$ 137) _____
 A) 3 B) 0 C) $\frac{1}{3}$ D) $-\infty$

138) $\lim_{t \rightarrow \infty} \frac{\sqrt{100t^2 - 1000}}{t - 10}$ 138) _____
 A) 1000 B) does not exist C) 100 D) 10

139) $\lim_{t \rightarrow \infty} \frac{\sqrt{16t^2 - 64}}{t - 4}$ 139) _____
 A) does not exist B) 16 C) 64 D) 4

140) $\lim_{x \rightarrow \infty} \frac{10x + 7}{\sqrt{7x^2 + 1}}$ 140) _____
 A) 0 B) ∞ C) $\frac{10}{\sqrt{7}}$ D) $\frac{10}{7}$

Find all horizontal asymptotes of the given function, if any.

141) $h(x) = \frac{6x - 8}{x - 5}$ 141) _____
 A) $y = 0$ B) $y = 5$
 C) $y = 6$ D) no horizontal asymptotes

142) $h(x) = 4 - \frac{6}{x}$ 142) _____
 A) $y = 6$ B) $x = 0$
 C) $y = 4$ D) no horizontal asymptotes

143) $g(x) = \frac{x^2 + 1x - 8}{x - 8}$ 143) _____
 A) $y = 0$ B) $y = 1$
 C) $y = 8$ D) no horizontal asymptotes

$$144) h(x) = \frac{5x^2 - 8x - 4}{7x^2 - 7x + 7}$$

144) _____

A) $y = \frac{8}{7}$

B) $y = 0$

C) $y = \frac{5}{7}$

D) no horizontal asymptotes

$$145) h(x) = \frac{3x^4 - 7x^2 - 2}{6x^5 - 2x + 3}$$

145) _____

A) $y = 0$

B) $y = \frac{7}{2}$

C) $y = \frac{1}{2}$

D) no horizontal asymptotes

$$146) h(x) = \frac{6x^3 - 9x}{2x^3 - 7x + 5}$$

146) _____

A) $y = 0$

B) $y = \frac{9}{7}$

C) $y = 3$

D) no horizontal asymptotes

$$147) h(x) = \frac{4x^3 - 7x - 2}{8x^2 + 6}$$

147) _____

A) $y = 0$

B) $y = 4$

C) $y = \frac{1}{2}$

D) no horizontal asymptotes

$$148) f(x) = \frac{4x + 1}{x^2 - 4}$$

148) _____

A) $y = 0$

B) $y = -2, y = 2$

C) $y = 4$

D) no horizontal asymptotes

$$149) R(x) = \frac{-3x^2 + 1}{x^2 + 6x - 40}$$

149) _____

A) $y = -10, y = 4$

B) $y = -3$

C) $y = 0$

D) no horizontal asymptotes

$$150) f(x) = \frac{x^2 - 4}{16x - x^4}$$

150) _____

A) no horizontal asymptotes

B) $y = -1$

C) $y = -4, y = 4$

D) $y = 0$

$$151) f(x) = \frac{16x^4 + x^2 - 4}{x - x^3}$$

151) _____

- A) $y = 0$
- C) $y = -16$

- B) $y = -1, y = 1$
- D) no horizontal asymptotes

SHORT ANSWER. Write the word or phrase that best completes each statement or answers the question.

Sketch the graph of a function $y = f(x)$ that satisfies the given conditions.

$$152) f(0) = 0, f(1) = 3, f(-1) = -3, \lim_{x \rightarrow -\infty} f(x) = -2, \lim_{x \rightarrow \infty} f(x) = 2.$$

152) _____

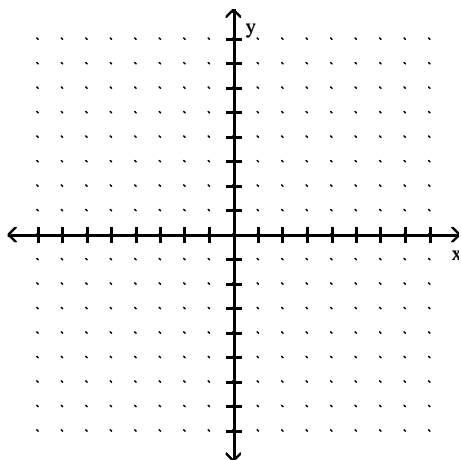

$$153) f(0) = 0, f(1) = 4, f(-1) = 4, \lim_{x \rightarrow \pm\infty} f(x) = -4.$$

153) _____

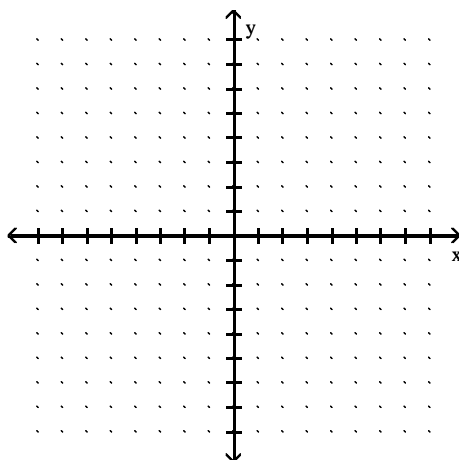

154) $f(0) = 5, f(1) = -5, f(-1) = -5, \lim_{x \rightarrow \pm\infty} f(x) = 0.$

154) _____

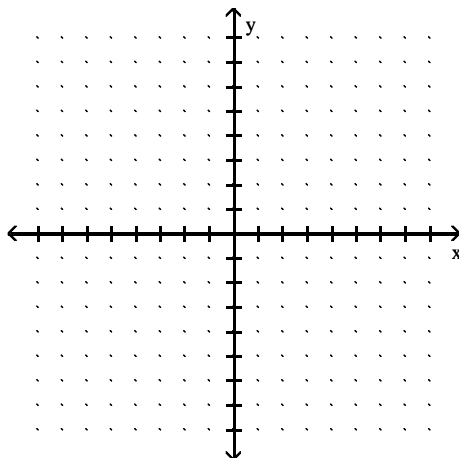

155) $f(0) = 0, \lim_{x \rightarrow \pm\infty} f(x) = 0, \lim_{x \rightarrow 3^-} f(x) = -\infty, \lim_{x \rightarrow -3^+} f(x) = -\infty, \lim_{x \rightarrow 3^+} f(x) = \infty, \lim_{x \rightarrow -3^-} f(x) = \infty.$

155) _____

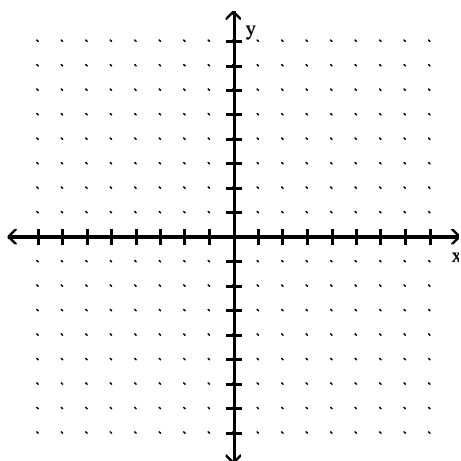

MULTIPLE CHOICE. Choose the one alternative that best completes the statement or answers the question.

Provide an appropriate response.

156) Find the vertical asymptote(s) of the graph of the given function.

156) _____

$$f(x) = \frac{3x - 9}{5x + 30}$$

- A) $y = 8$ B) $x = -6$ C) $x = -8$ D) $y = -3$

157) Find the vertical asymptote(s) of the graph of the given function.

157) _____

$$f(x) = \frac{x^2 - 100}{(x - 9)(x + 3)}$$

- A) $x = -9$ B) $x = 10, x = -10$ C) $x = 9, x = -3$ D) $y = 9, y = -3$

158) Find the horizontal asymptote, if any, of the given function.

158) _____

$$f(x) = \frac{(x - 3)(x + 4)}{x^2 - 4}$$

- A) $y = 3, y = -4$ B) $y = 1$ C) $x = 2, x = -2$ D) None

159) Find the horizontal asymptote, if any, of the given function.

159) _____

$$f(x) = \frac{2x^3 - 3x - 9}{9x^3 - 5x + 3}$$

A) $y = \frac{3}{5}$

B) $y = 0$

C) $y = \frac{2}{9}$

D) None

Find all points where the function is discontinuous.

160)

160) _____

A) $x = 4$

B) None

C) $x = 4, x = 2$

D) $x = 2$

161)

161) _____

A) $x = -2, x = 1$

B) None

C) $x = -2$

D) $x = 1$

162)

162) _____

A) $x = 2$

B) $x = -2, x = 0$

C) $x = 0, x = 2$

D) $x = -2, x = 0, x = 2$

163)

163) _____

A) $x = -2$

B) $x = -2, x = 6$

C) $x = 6$

D) None

164)

164) _____

- A) None
- C) $x = 1, x = 4, x = 5$

- B) $x = 1, x = 5$
- D) $x = 4$

165)

165) _____

A) $x = 0$

B) $x = 0, x = 1$

C) None

D) $x = 1$

166)

166) _____

A) None

B) $x = 0$

C) $x = 3$

D) $x = 0, x = 3$

167)

167) _____

A) None

B) $x = -2$

C) $x = 2$

D) $x = -2, x = 2$

168)

168) _____

- A) $x = -2, x = 0, x = 2$
- C) None

- B) $x = -2, x = 2$
- D) $x = 0$

Provide an appropriate response.

169) Is f continuous at $f(1)$?

169) _____

$$f(x) = \begin{cases} -x^2 + 1, & -1 \leq x < 0 \\ 4x, & 0 < x < 1 \\ -5, & x = 1 \\ -4x + 8, & 1 < x < 3 \\ 1, & 3 < x < 5 \end{cases}$$

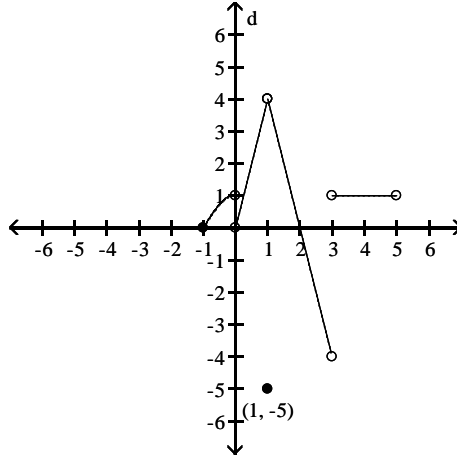

A) No

B) Yes

170) Is f continuous at $f(0)$?

170) _____

$$f(x) = \begin{cases} -x^2 + 1, & -1 \leq x < 0 \\ 5x, & 0 < x < 1 \\ -2, & x = 1 \\ -5x + 10, & 1 < x < 3 \\ 5, & 3 < x < 5 \end{cases}$$

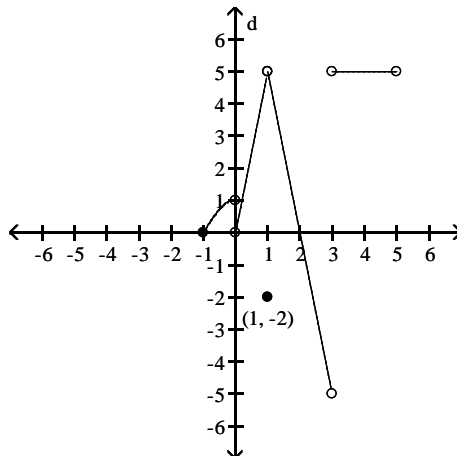

A) No

B) Yes

171) Is f continuous at $x = 0$?

171) _____

$$f(x) = \begin{cases} x^3, & -2 < x \leq 0 \\ -4x, & 0 \leq x < 2 \\ 4, & 2 < x \leq 4 \\ 0, & x = 2 \end{cases}$$

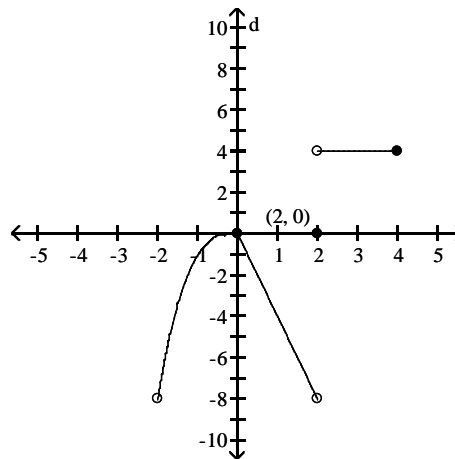

A) No

B) Yes

172) Is f continuous at $x = 4$?

172) _____

$$f(x) = \begin{cases} x^3, & -2 < x \leq 0 \\ -2x, & 0 \leq x < 2 \\ 3, & 2 < x \leq 4 \\ 0, & x = 2 \end{cases}$$

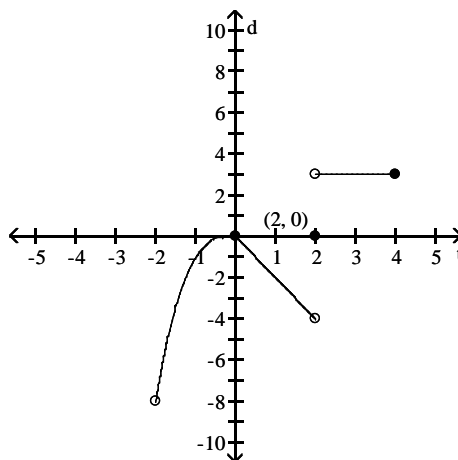

A) No

B) Yes

173) Is the function given by $f(x) = \frac{x+2}{x^2-3x+2}$ continuous at $x = 1$? Why or why not?

173) _____

A) Yes, $\lim_{x \rightarrow 1} f(x) = f(1)$

B) No, $f(1)$ does not exist and $\lim_{x \rightarrow 1} f(x)$ does not exist

174) Is the function given by $f(x) = \sqrt{10x+10}$ continuous at $x = -1$? Why or why not?

174) _____

A) No, $\lim_{x \rightarrow -1} f(x)$ does not exist

B) Yes, $\lim_{x \rightarrow -1} f(x) = f(-1)$

175) Is the function given by $f(x) = \begin{cases} x^2 - 3, & \text{for } x < 0 \\ -4, & \text{for } x \geq 0 \end{cases}$ continuous at $x = -3$? Why or why not?

175) _____

A) Yes, $\lim_{x \rightarrow -3} f(x) = f(-3)$

B) No, $\lim_{x \rightarrow -3} f(x) = f(-3)$ does not exist

176) Is the function given by $f(x) = \begin{cases} \frac{1}{x-2}, & \text{for } x > 2 \\ x^2 - 2x, & \text{for } x \leq 2 \end{cases}$ continuous at $x = 2$? Why or why not?

176) _____

A) Yes, $\lim_{x \rightarrow 2} f(x) = f(2)$

B) No, $\lim_{x \rightarrow 2} f(x)$ does not exist

Find the intervals on which the function is continuous.

177) $y = \frac{2}{x+7} - 2x$

177) _____

A) discontinuous only when $x = -9$

B) continuous everywhere

C) discontinuous only when $x = -7$

D) discontinuous only when $x = 7$

178) $y = \frac{1}{(x+5)^2 + 10}$

178) _____

A) discontinuous only when $x = 35$

B) discontinuous only when $x = -5$

C) continuous everywhere

D) discontinuous only when $x = -40$

179) $y = \frac{x + 3}{x^2 - 5x + 4}$ 179) _____

- A) discontinuous only when $x = -4$ or $x = 1$
 C) discontinuous only when $x = -1$ or $x = 4$

- B) discontinuous only when $x = 1$
 D) discontinuous only when $x = 1$ or $x = 4$

180) $y = \frac{1}{x^2 - 9}$ 180) _____

- A) discontinuous only when $x = -3$
 C) discontinuous only when $x = 9$

- B) discontinuous only when $x = -9$ or $x = 9$
 D) discontinuous only when $x = -3$ or $x = 3$

181) $y = \frac{1}{|x| + 4} - \frac{x^2}{5}$ 181) _____

- A) discontinuous only when $x = -4$
 C) continuous everywhere

- B) discontinuous only when $x = -9$
 D) discontinuous only when $x = -5$ or $x = -4$

182) $y = \frac{\sin(4\theta)}{2\theta}$ 182) _____

- A) continuous everywhere
 C) discontinuous only when $\theta = \frac{\pi}{2}$

- B) discontinuous only when $\theta = \pi$
 D) discontinuous only when $\theta = 0$

183) $y = \frac{5 \cos \theta}{\theta + 10}$ 183) _____

- A) discontinuous only when $\theta = 10$
 C) continuous everywhere

- B) discontinuous only when $\theta = \frac{\pi}{2}$
 D) discontinuous only when $\theta = -10$

184) $y = \sqrt{7x + 6}$ 184) _____

- A) continuous on the interval $\left[-\frac{6}{7}, \infty\right)$
 C) continuous on the interval $\left[\frac{6}{7}, \infty\right)$

- B) continuous on the interval $\left(-\infty, -\frac{6}{7}\right]$
 D) continuous on the interval $\left[-\frac{6}{7}, \infty\right)$

185) $y = \sqrt[4]{6x - 4}$ 185) _____

- A) continuous on the interval $\left[-\frac{2}{3}, \infty\right)$
 C) continuous on the interval $\left(-\infty, \frac{2}{3}\right]$

- B) continuous on the interval $\left(\frac{2}{3}, \infty\right)$
 D) continuous on the interval $\left[\frac{2}{3}, \infty\right)$

186) $y = \sqrt{x^2 - 7}$

- A) continuous on the interval $[\sqrt{7}, \infty)$
- B) continuous on the interval $[-\sqrt{7}, \sqrt{7}]$
- C) continuous on the intervals $(-\infty, -\sqrt{7}]$ and $[\sqrt{7}, \infty)$
- D) continuous everywhere

186) _____

Find the limit, if it exists.

187) $\lim_{x \rightarrow -3} (x^2 - 16 + \sqrt[3]{x^2 - 36})$

- A) 4
- B) -4
- C) -10
- D) Does not exist

187) _____

188) $\lim_{x \rightarrow \infty} \left(\frac{5x - 1}{x} \right)^3$

- A) 125
- B) Does not exist
- C) 64
- D) ∞

188) _____

Provide an appropriate response.

189) Is f continuous on $(-2, 4]$?

189) _____

$$f(x) = \begin{cases} x^3, & -2 < x \leq 0 \\ -4x, & 0 \leq x < 2 \\ 4, & 2 < x \leq 4 \\ 0, & x = 2 \end{cases}$$

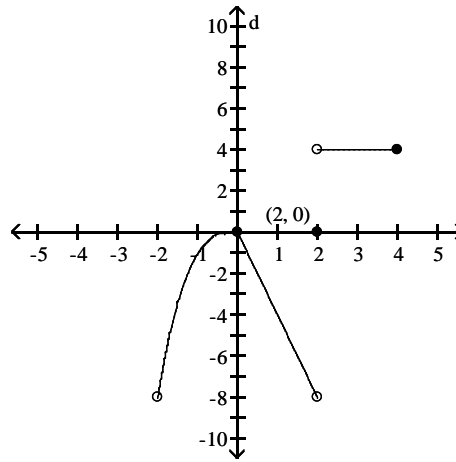

- A) No
- B) Yes

Find the limit, if it exists.

190) $\lim_{x \rightarrow -3} (x^2 - 16 + \sqrt[3]{x^2 - 36})$

- A) -4
- B) Does not exist
- C) -10
- D) 4

190) _____

191) $\lim_{x \rightarrow 5} \sqrt{x^2 + 12x + 36}$

- A) 121
- B) 11
- C) Does not exist
- D) ± 11

191) _____

192) $\lim_{x \rightarrow 2} \sqrt{x - 5}$

- A) 1.73205081
- B) -1.7320508
- C) Does not exist
- D) 0

192) _____

- 193) $\lim_{x \rightarrow 14} \sqrt{x^2 - 9}$ 193) _____
 A) 93.5 B) $\pm\sqrt{187}$ C) $\sqrt{187}$ D) Does not exist
- 194) $\lim_{x \rightarrow -8^-} \sqrt{x^2 - 64}$ 194) _____
 A) $8\sqrt{6}$ B) 4 C) 0 D) Does not exist
- 195) $\lim_{x \rightarrow 3^+} \frac{6\sqrt{(x-3)^3}}{x-3}$ 195) _____
 A) 6 B) 0 C) $6\sqrt{3}$ D) Does not exist
- 196) $\lim_{t \rightarrow 1^+} \frac{\sqrt{(t+36)(t-1)^2}}{13t-13}$ 196) _____
 A) $\frac{\sqrt{37}}{13}$ B) $\frac{1}{13}$ C) 0 D) Does not exist

SHORT ANSWER. Write the word or phrase that best completes each statement or answers the question.

Provide an appropriate response.

- 197) Use the Intermediate Value Theorem to prove that $9x^3 - 5x^2 + 10x + 10 = 0$ has a solution between -1 and 0. 197) _____
- 198) Use the Intermediate Value Theorem to prove that $8x^4 + 4x^3 - 7x - 5 = 0$ has a solution between -1 and 0. 198) _____
- 199) Use the Intermediate Value Theorem to prove that $x(x-6)^2 = 6$ has a solution between 5 and 7. 199) _____
- 200) Use the Intermediate Value Theorem to prove that $6 \sin x = x$ has a solution between $\frac{\pi}{2}$ and π . 200) _____

MULTIPLE CHOICE. Choose the one alternative that best completes the statement or answers the question.

Find numbers a and b, or k, so that f is continuous at every point.

- 201) 201) _____

$$f(x) = \begin{cases} -4, & x < -4 \\ ax + b, & -4 \leq x \leq -3 \\ 5, & x > -3 \end{cases}$$
 A) $a = -4, b = 5$ B) $a = 9, b = -22$ C) $a = 9, b = 32$ D) Impossible

202) _____ 202) _____

$$f(x) = \begin{cases} x^2, & x < -4 \\ ax + b, & -4 \leq x \leq 5 \\ x + 20, & x > 5 \end{cases}$$

- A) $a = -1, b = 20$ B) $a = 1, b = 20$ C) $a = 1, b = -20$ D) Impossible

203) _____ 203) _____

$$f(x) = \begin{cases} 3x + 9, & \text{if } x < -6 \\ kx + 6, & \text{if } x \geq -6 \end{cases}$$

- A) $k = 1$ B) $k = 6$ C) $k = -1$ D) $k = \frac{5}{2}$

204) _____ 204) _____

$$f(x) = \begin{cases} x^2, & \text{if } x \leq 4 \\ x + k, & \text{if } x > 4 \end{cases}$$

- A) $k = -4$ B) $k = 12$ C) $k = 20$ D) Impossible

205) _____ 205) _____

$$f(x) = \begin{cases} x^2, & \text{if } x \leq 5 \\ kx, & \text{if } x > 5 \end{cases}$$

- A) $k = 5$ B) $k = \frac{1}{5}$ C) $k = 25$ D) Impossible

Solve the problem.

206) Select the correct statement for the definition of the limit: $\lim_{x \rightarrow x_0} f(x) = L$ 206) _____

means that _____

- A) if given a number $\varepsilon > 0$, there exists a number $\delta > 0$, such that for all x , $0 < |x - x_0| < \delta$ implies $|f(x) - L| > \varepsilon$.
- B) if given any number $\varepsilon > 0$, there exists a number $\delta > 0$, such that for all x , $0 < |x - x_0| < \varepsilon$ implies $|f(x) - L| < \delta$.
- C) if given any number $\varepsilon > 0$, there exists a number $\delta > 0$, such that for all x , $0 < |x - x_0| < \varepsilon$ implies $|f(x) - L| > \delta$.
- D) if given any number $\varepsilon > 0$, there exists a number $\delta > 0$, such that for all x , $0 < |x - x_0| < \delta$ implies $|f(x) - L| < \varepsilon$.

207) Identify the incorrect statements about limits. 207) _____

- I. The number L is the limit of $f(x)$ as x approaches x_0 if $f(x)$ gets closer to L as x approaches x_0 .
- II. The number L is the limit of $f(x)$ as x approaches x_0 if, for any $\varepsilon > 0$, there corresponds a $\delta > 0$ such that $|f(x) - L| < \varepsilon$ whenever $0 < |x - x_0| < \delta$.
- III. The number L is the limit of $f(x)$ as x approaches x_0 if, given any $\varepsilon > 0$, there exists a value of x for which $|f(x) - L| < \varepsilon$.

- A) I and II B) II and III C) I and III D) I, II, and III

Use the graph to find a $\delta > 0$ such that for all x , $0 < |x - x_0| < \delta \Rightarrow |f(x) - L| < \varepsilon$.

208)

208) _____

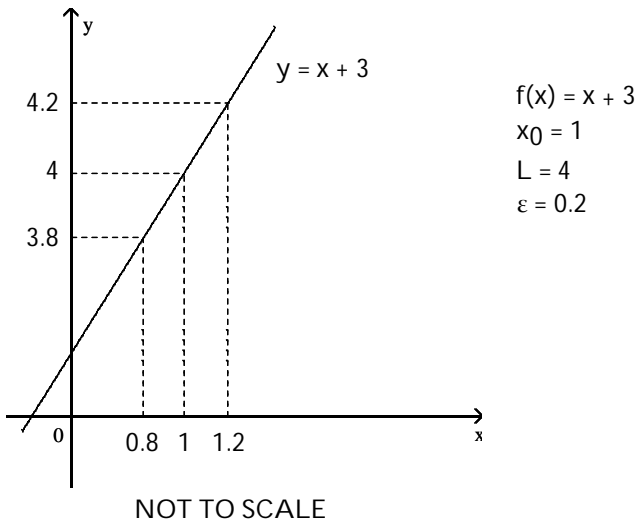

A) 0.1

B) 0.4

C) 3

D) 0.2

209)

209) _____

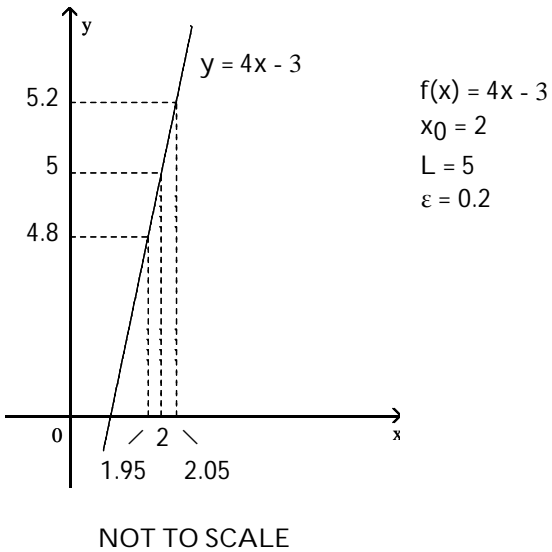

A) 0.05

B) 0.1

C) 3

D) 0.5

210)

210) _____

$f(x) = -4x - 2$
 $x_0 = -2$
 $L = 6$
 $\varepsilon = 0.2$

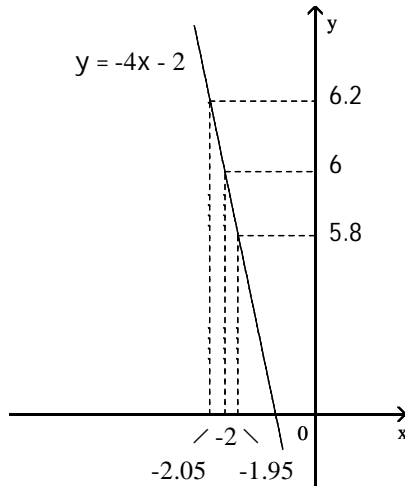

NOT TO SCALE

A) 0.5

B) -0.05

C) 12

D) 0.05

211)

211) _____

$f(x) = -2x + 3$
 $x_0 = -2$
 $L = 7$
 $\varepsilon = 0.2$

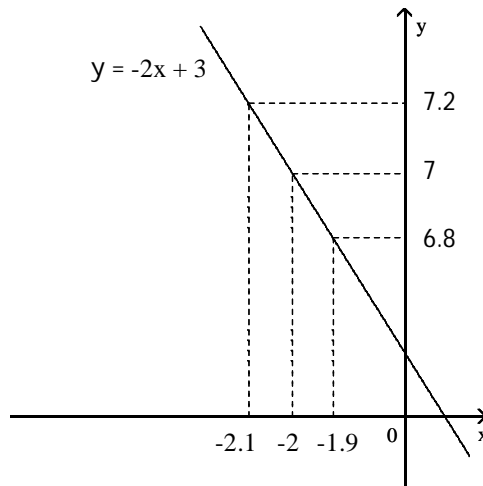

NOT TO SCALE

A) 0.1

B) -0.1

C) 9

D) 0.2

212)

212) _____

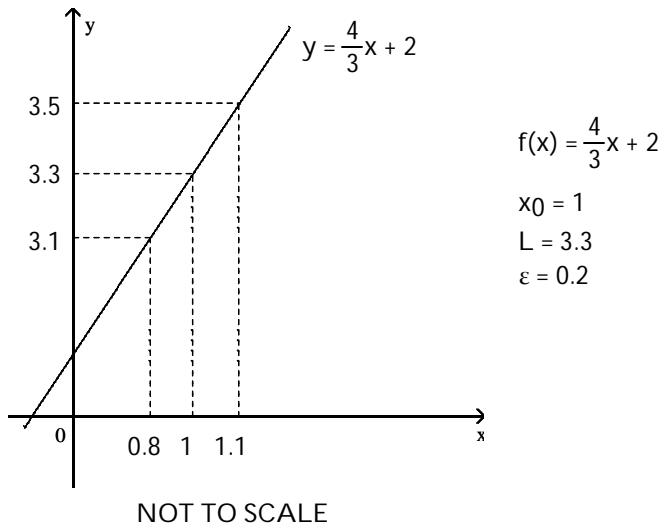

A) 2.3

B) 0.1

C) 0.3

D) -0.3

213)

213) _____

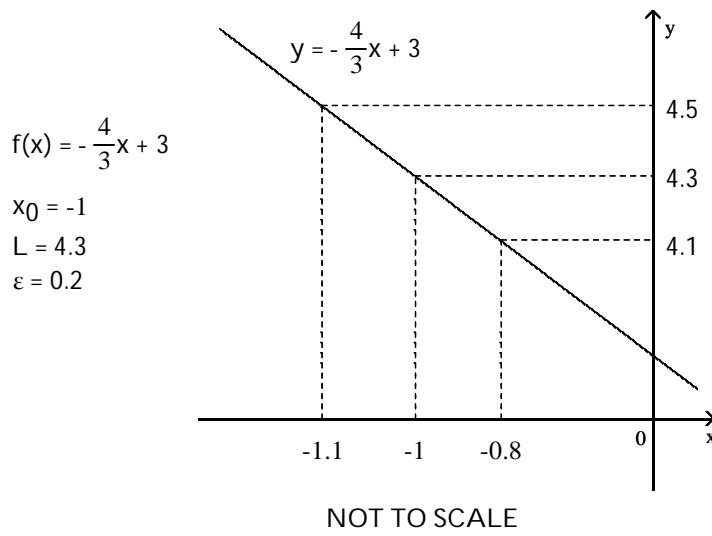

A) -0.3

B) 5.3

C) 0.1

D) 0.3

214)

214) _____

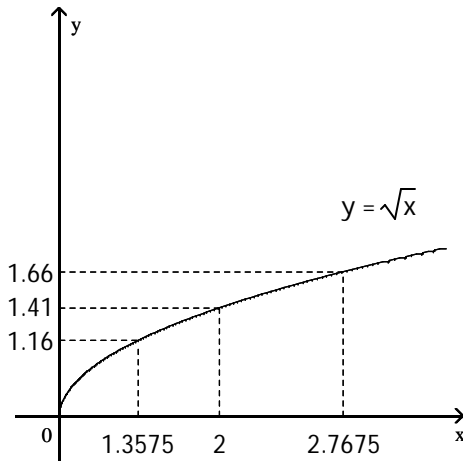

$$f(x) = \sqrt{x}$$

$$x_0 = 2$$

$$L = \sqrt{2}$$

$$\varepsilon = \frac{1}{4}$$

NOT TO SCALE

A) -0.59

B) 0.6425

C) 0.7675

D) 1.41

215)

215) _____

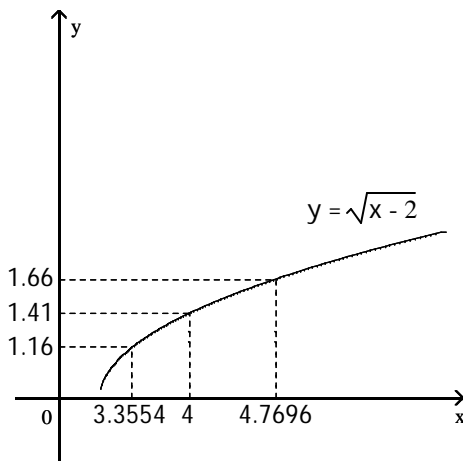

$$f(x) = \sqrt{x-2}$$

$$x_0 = 4$$

$$L = \sqrt{2}$$

$$\varepsilon = \frac{1}{4}$$

NOT TO SCALE

A) 2.59

B) 0.7696

C) 0.6446

D) 1.4142

216)

216) _____

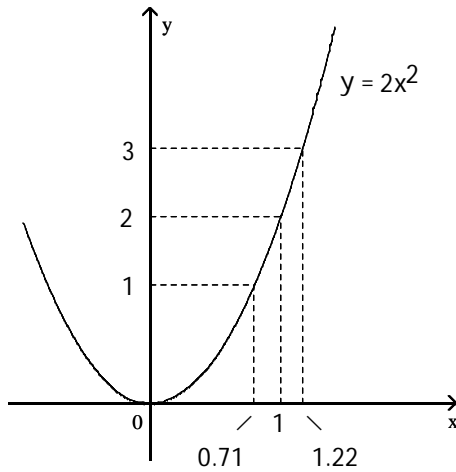

$$f(x) = 2x^2$$

$$x_0 = 1$$

$$L = 2$$

$$\varepsilon = 1$$

NOT TO SCALE

A) 0.29

B) 0.51

C) 1

D) 0.22

217)

217) _____

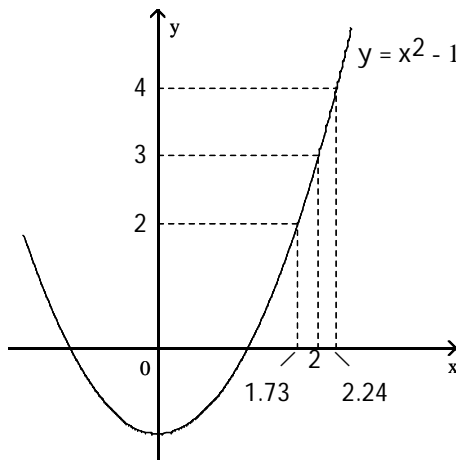

$$f(x) = x^2 - 1$$

$$x_0 = 2$$

$$L = 3$$

$$\varepsilon = 1$$

NOT TO SCALE

A) 0.51

B) 0.24

C) 1

D) 0.27

A function $f(x)$, a point x_0 , the limit of $f(x)$ as x approaches x_0 , and a positive number ε is given. Find a number $\delta > 0$ such that for all x , $0 < |x - x_0| < \delta \Rightarrow |f(x) - L| < \varepsilon$.

218) $f(x) = 6x + 5$, $L = 17$, $x_0 = 2$, and $\varepsilon = 0.01$

218) _____

A) 0.008333

B) 0.005

C) 0.001667

D) 0.003333

219) $f(x) = 7x - 2$, $L = 12$, $x_0 = 2$, and $\varepsilon = 0.01$

219) _____

A) 0.000714

B) 0.001429

C) 0.002857

D) 0.005

220) $f(x) = -2x + 9$, $L = 1$, $x_0 = 4$, and $\varepsilon = 0.01$

220) _____

A) 0.02

B) 0.005

C) 0.01

D) -0.0025

221) $f(x) = -10x - 1$, $L = -11$, $x_0 = 1$, and $\epsilon = 0.01$

A) 0.01

B) 0.001

C) 0.002

D) 0.0005

221) _____

222) $f(x) = 6x^2$, $L = 150$, $x_0 = 5$, and $\epsilon = 0.4$

A) 4.99333

B) 0.00666

C) 5.00666

D) 0.00667

222) _____

SHORT ANSWER. Write the word or phrase that best completes each statement or answers the question.

Prove the limit statement

223) $\lim_{x \rightarrow 2} (3x - 4) = 2$

223) _____

224) $\lim_{x \rightarrow 7} \frac{x^2 - 49}{x - 7} = 14$

224) _____

225) $\lim_{x \rightarrow 9} \frac{2x^2 - 15x - 27}{x - 9} = 21$

225) _____

226) $\lim_{x \rightarrow 7} \frac{1}{x} = \frac{1}{7}$

226) _____

Answer Key

Testname: UNTITLED2

- 1) C
- 2) C
- 3) B
- 4) A
- 5) A
- 6) A
- 7) C
- 8) B
- 9) D
- 10) B
- 11) A
- 12) C
- 13) A
- 14) D
- 15) A
- 16) A
- 17) A
- 18) C
- 19) D
- 20) C
- 21) D
- 22) D
- 23) B
- 24) A
- 25) D
- 26) D
- 27) D
- 28) C
- 29) C
- 30) D
- 31) B
- 32) A
- 33) A
- 34) D
- 35) D
- 36) C
- 37) C
- 38) C
- 39) C
- 40) B
- 41) C

42) Answers may vary. One possibility: $\lim_{x \rightarrow 0} 1 - \frac{x^2}{6} = \lim_{x \rightarrow 0} 1 = 1$. According to the squeeze theorem, the function

$\frac{x \sin(x)}{2 - 2 \cos(x)}$, which is squeezed between $1 - \frac{x^2}{6}$ and 1, must also approach 1 as x approaches 0. Thus,

$$\lim_{x \rightarrow 0} \frac{x \sin(x)}{2 - 2 \cos(x)} = 1.$$

43) D

Answer Key

Testname: UNTITLED2

- 44) A
- 45) D
- 46) A
- 47) C
- 48) B
- 49) B
- 50) D
- 51) C
- 52) D
- 53) D
- 54) C
- 55) B
- 56) A
- 57) C
- 58) C
- 59) D
- 60) B
- 61) C
- 62) A
- 63) D
- 64) C
- 65) B
- 66) A
- 67) D
- 68) D
- 69) D
- 70) C
- 71) C
- 72) B
- 73) B
- 74) A
- 75) D
- 76) D
- 77) D
- 78) C
- 79) C
- 80) A
- 81) A
- 82) B
- 83) B
- 84) D
- 85) B
- 86) C
- 87) B
- 88) D
- 89) B
- 90) C
- 91) B
- 92) C
- 93) D

Answer Key

Testname: UNTITLED2

- 94) D
- 95) A
- 96) C
- 97) B
- 98) B
- 99) C
- 100) B
- 101) D
- 102) D
- 103) A
- 104) D
- 105) A
- 106) D
- 107) B
- 108) B
- 109) D
- 110) B
- 111) C
- 112) A
- 113) D
- 114) A
- 115) D
- 116) B
- 117) B
- 118) A
- 119) B
- 120) D
- 121) B
- 122) B
- 123) D
- 124) D
- 125) B
- 126) D
- 127) C
- 128) D
- 129) A
- 130) B
- 131) A
- 132) D
- 133) C
- 134) B
- 135) B
- 136) D
- 137) A
- 138) D
- 139) D
- 140) C
- 141) C
- 142) C
- 143) D

Answer Key

Testname: UNTITLED2

144) C

145) A

146) C

147) D

148) A

149) B

150) D

151) D

152) Answers may vary. One possible answer:

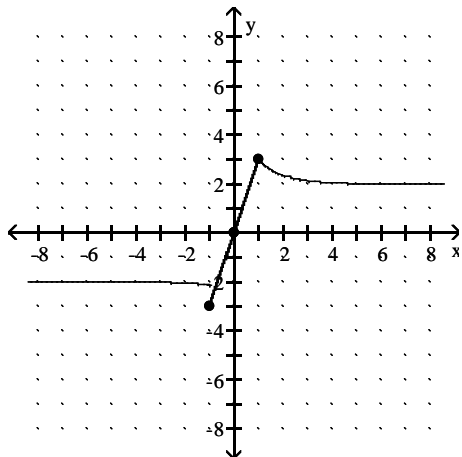

153) Answers may vary. One possible answer:

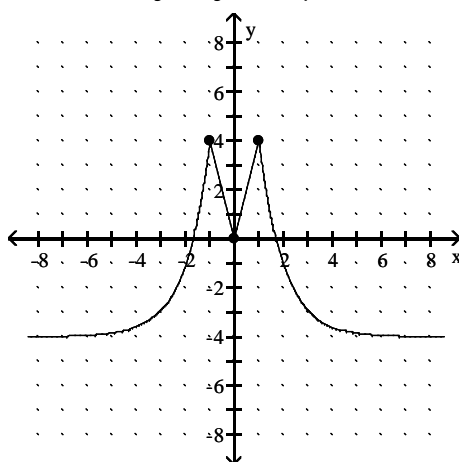

Answer Key

Testname: UNTITLED2

154) Answers may vary. One possible answer:

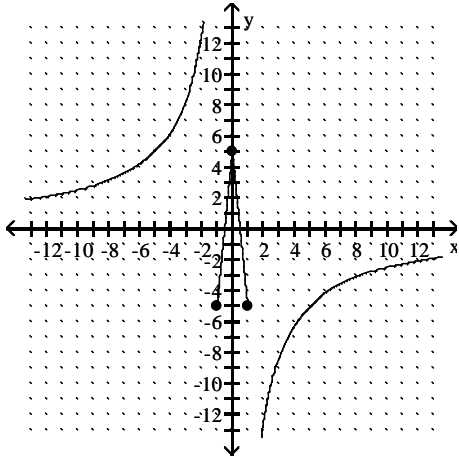

155) Answers may vary. One possible answer:

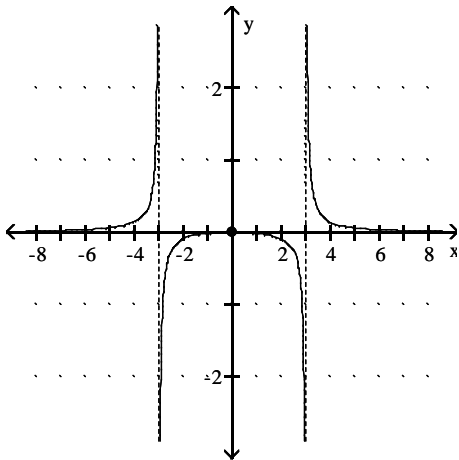

- 156) B
- 157) C
- 158) B
- 159) C
- 160) A
- 161) D
- 162) D
- 163) C
- 164) A
- 165) C
- 166) C
- 167) D
- 168) D
- 169) A
- 170) A
- 171) B
- 172) B
- 173) B
- 174) A
- 175) A
- 176) B

Answer Key

Testname: UNTITLED2

- 177) C
- 178) C
- 179) D
- 180) D
- 181) C
- 182) D
- 183) D
- 184) A
- 185) D
- 186) C
- 187) C
- 188) A
- 189) A
- 190) C
- 191) B
- 192) C
- 193) C
- 194) C
- 195) B
- 196) A

197) Let $f(x) = 9x^3 - 5x^2 + 10x + 10$ and let $y_0 = 0$. $f(-1) = -14$ and $f(0) = 10$. Since f is continuous on $[-1, 0]$ and since $y_0 = 0$ is between $f(-1)$ and $f(0)$, by the Intermediate Value Theorem, there exists a c in the interval $(-1, 0)$ with the property that $f(c) = 0$. Such a c is a solution to the equation $9x^3 - 5x^2 + 10x + 10 = 0$.

198) Let $f(x) = 8x^4 + 4x^3 - 7x - 5$ and let $y_0 = 0$. $f(-1) = 6$ and $f(0) = -5$. Since f is continuous on $[-1, 0]$ and since $y_0 = 0$ is between $f(-1)$ and $f(0)$, by the Intermediate Value Theorem, there exists a c in the interval $(-1, 0)$ with the property that $f(c) = 0$. Such a c is a solution to the equation $8x^4 + 4x^3 - 7x - 5 = 0$.

199) Let $f(x) = x(x - 6)^2$ and let $y_0 = 6$. $f(5) = 5$ and $f(7) = 7$. Since f is continuous on $[5, 7]$ and since $y_0 = 6$ is between $f(5)$ and $f(7)$, by the Intermediate Value Theorem, there exists a c in the interval $(5, 7)$ with the property that $f(c) = 6$. Such a c is a solution to the equation $x(x - 6)^2 = 6$.

200) Let $f(x) = \frac{\sin x}{x}$ and let $y_0 = \frac{1}{6}$. $f\left(\frac{\pi}{2}\right) \approx 0.6366$ and $f(\pi) = 0$. Since f is continuous on $\left[\frac{\pi}{2}, \pi\right]$ and since $y_0 = \frac{1}{6}$ is between $f\left(\frac{\pi}{2}\right)$ and $f(\pi)$, by the Intermediate Value Theorem, there exists a c in the interval $\left(\frac{\pi}{2}, \pi\right)$, with the property that $f(c) = \frac{1}{6}$.

Such a c is a solution to the equation $6 \sin x = x$.

- 201) C
- 202) B
- 203) D
- 204) B
- 205) A
- 206) D
- 207) C
- 208) D
- 209) A
- 210) D
- 211) A
- 212) B
- 213) C
- 214) B

Answer Key

Testname: UNTITLED2

215) C

216) D

217) B

218) C

219) B

220) B

221) B

222) B

223)

Let $\varepsilon > 0$ be given. Choose $\delta = \varepsilon/3$. Then $0 < |x - 2| < \delta$ implies that

$$\begin{aligned} |(3x - 4) - 2| &= |3x - 6| \\ &= |3(x - 2)| \\ &= 3|x - 2| < 3\delta = \varepsilon \end{aligned}$$

Thus, $0 < |x - 2| < \delta$ implies that $|(3x - 4) - 2| < \varepsilon$ 224) Let $\varepsilon > 0$ be given. Choose $\delta = \varepsilon$. Then $0 < |x - 7| < \delta$ implies that

$$\begin{aligned} \left| \frac{x^2 - 49}{x - 7} - 14 \right| &= \left| \frac{(x - 7)(x + 7)}{x - 7} - 14 \right| \\ &= |(x + 7) - 14| \quad \text{for } x \neq 7 \\ &= |x - 7| < \delta = \varepsilon \end{aligned}$$

Thus, $0 < |x - 7| < \delta$ implies that $\left| \frac{x^2 - 49}{x - 7} - 14 \right| < \varepsilon$ 225) Let $\varepsilon > 0$ be given. Choose $\delta = \varepsilon/2$. Then $0 < |x - 9| < \delta$ implies that

$$\begin{aligned} \left| \frac{2x^2 - 15x - 27}{x - 9} - 21 \right| &= \left| \frac{(x - 9)(2x + 3)}{x - 9} - 21 \right| \\ &= |(2x + 3) - 21| \quad \text{for } x \neq 9 \\ &= |2x - 18| \\ &= |2(x - 9)| \\ &= 2|x - 9| < 2\delta = \varepsilon \end{aligned}$$

Thus, $0 < |x - 9| < \delta$ implies that $\left| \frac{2x^2 - 15x - 27}{x - 9} - 21 \right| < \varepsilon$ 226) Let $\varepsilon > 0$ be given. Choose $\delta = \min\{7/2, 49\varepsilon/2\}$. Then $0 < |x - 7| < \delta$ implies that

$$\begin{aligned} \left| \frac{1}{x} - \frac{1}{7} \right| &= \left| \frac{7 - x}{7x} \right| \\ &= \frac{1}{|x|} \cdot \frac{1}{7} \cdot |x - 7| \\ &< \frac{1}{7/2} \cdot \frac{1}{7} \cdot \frac{49\varepsilon}{2} = \varepsilon \end{aligned}$$

Thus, $0 < |x - 7| < \delta$ implies that $\left| \frac{1}{x} - \frac{1}{7} \right| < \varepsilon$